

Design File: hcs1tolvds.ffe
HyperLynx v8.1.1

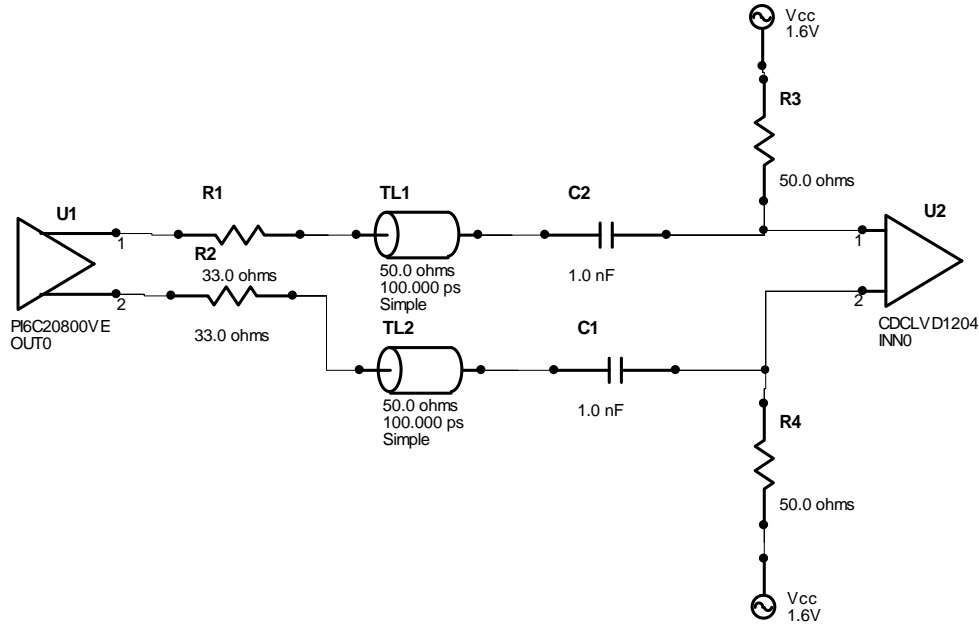

Figure 1. HCSL to LVDS schematic proposal

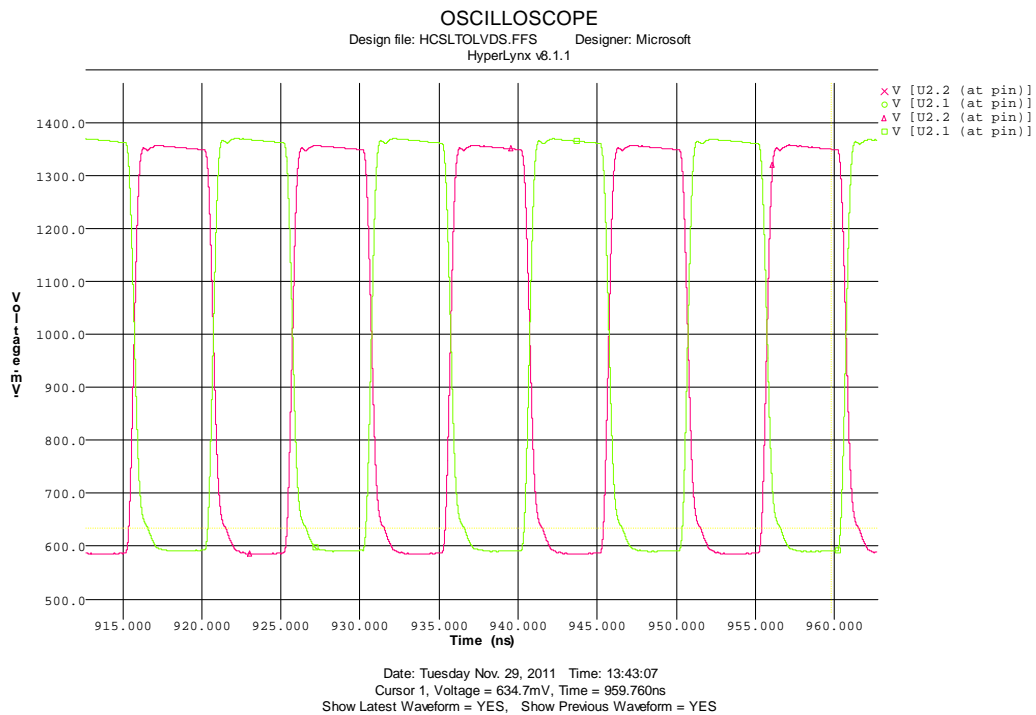

Figure 2. HCSL to LVDS. Receiver CDCLVD1204 simulated from schematic in Figure 1

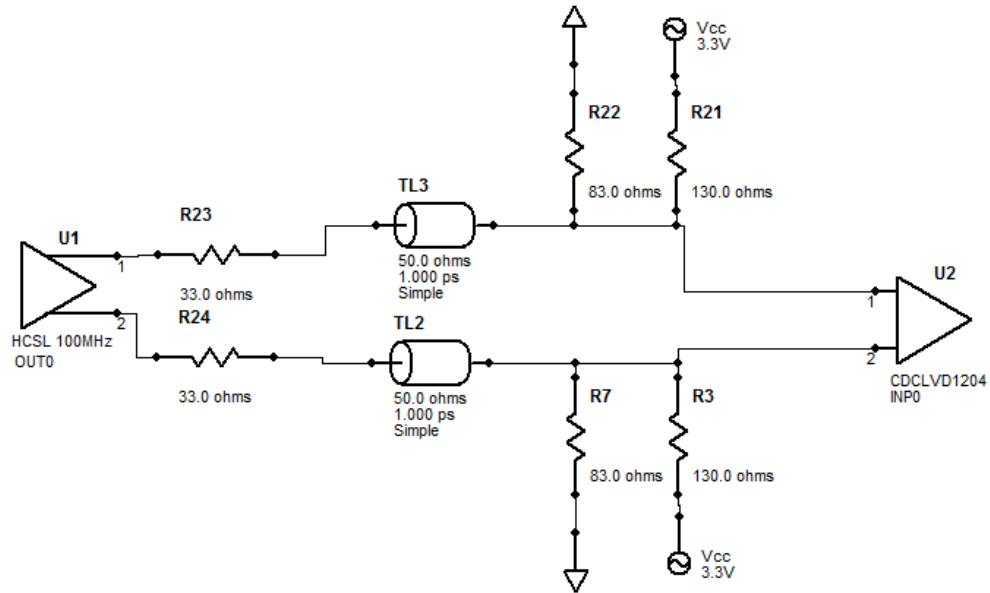

Figure 3. HCSL to LVDS DC coupled

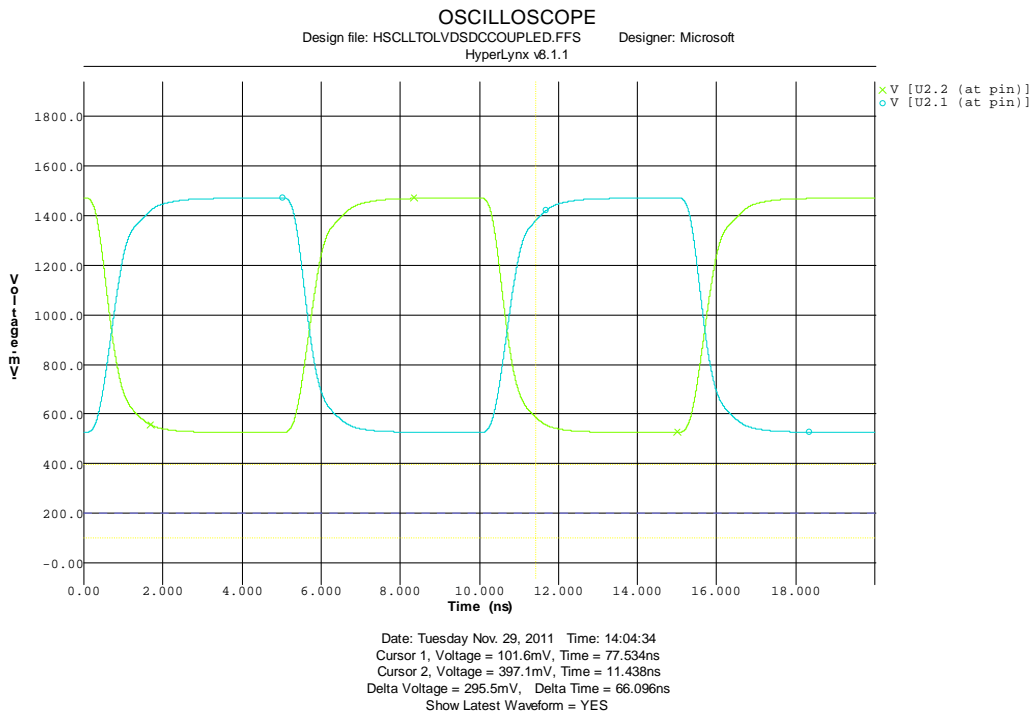

Figure 4. HCSL to LVDS. Receiver CDCLVD1204 simulated from schematic in Figure 3