

TLV2374IPWR : Connection diagram

P5=+5V,N5=-5V

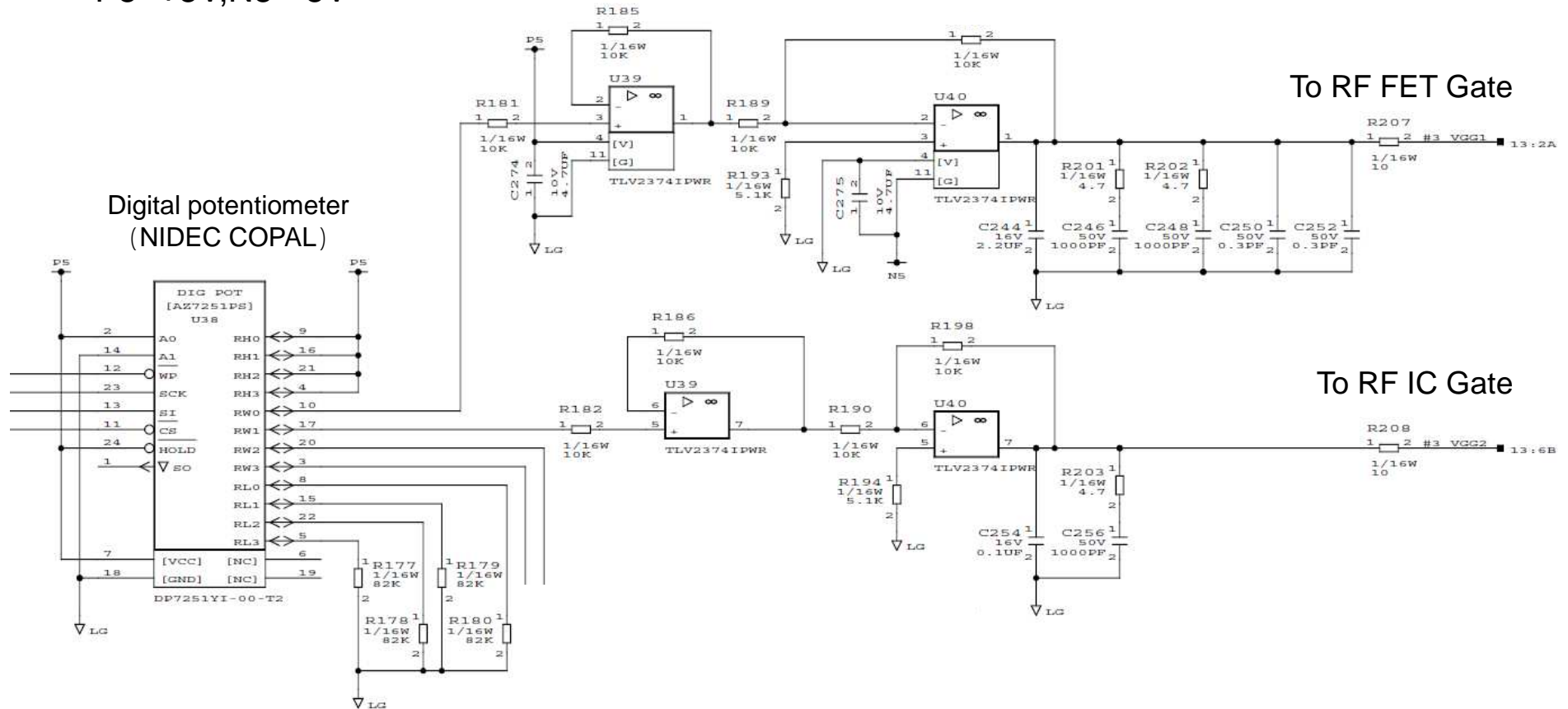

Situation

- U40 breaks down in the short mode.
- U39 has no abnormalities.

Background

- It was normal although examinations various about several months were done.
- Abnormalities were checked, as a result of changing the evaluation system of a trial product and performing power supply starting.
- Those with a possibility that humidity management was not enough at that time, and dew condensation occurred inside the trial product although the low temperature test was carried out before the examination.
- At the time of change of evaluation, a signal wire has a wiring mistake in part, and the trial product carried out unusual operation.
- Those with a possibility that the gate portion of the semiconductor of high frequency drew current greatly at this time.