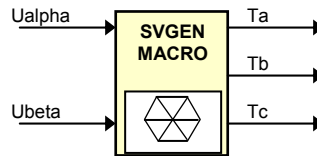

**Description**

This module calculates the appropriate duty ratios needed to generate a given stator reference voltage using space vector PWM technique. The stator reference voltage is described by its  $(\alpha, \beta)$  components, Ualpha and Ubeta.

**Availability**

This IQ module is available in one interface format:

- 1) The C interface version

**Module Properties**

**Type:** Target Independent, Application Independent

**Target Devices:** 28x Fixed and Floating Point devices

**C Version File Names:** svgen\_dq.h

**IQmath library files for C:** IQmathLib.h, IQmath.lib

## C Interface

---

### C Interface

#### Object Definition

The structure of SVGENDQ object is defined by following structure definition

```
typedef struct {_iq Ualpha; // Input: reference alpha-axis phase voltage
               _iq Ubeta; // Input: reference beta-axis phase voltage
               _iq Ta;    // Output: reference phase-a switching function
               _iq Tb;    // Output: reference phase-b switching function
               _iq Tc;    // Output: reference phase-c switching function
               } SVGENDQ;
```

```
typedef SVGENDQ *SVGENDQ_handle;
```

Item	Name	Description	Format	Range(Hex)
Inputs	Ualpha	Component of reference stator voltage vector on direct axis stationary reference frame.	GLOBAL_Q	80000000-7FFFFFFF
	Ubeta	Component of reference stator voltage vector on quadrature axis stationary reference frame.	GLOBAL_Q	80000000-7FFFFFFF
Outputs	Ta	Duty ratio of PWM1 (CMPR1 register value as a fraction of associated period register, TxPR, value).	GLOBAL_Q	80000000-7FFFFFFF
	Tb	Duty ratio of PWM3 (CMPR2 register value as a fraction of associated period register, TxPR, value).	GLOBAL_Q	80000000-7FFFFFFF
	Tc	Duty ratio of PWM5 (CMPR3 register value as a fraction of associated period register, TxPR, value).	GLOBAL_Q	80000000-7FFFFFFF

GLOBAL\_Q valued between 1 and 30 is defined in the IQmathLib.h header file.

### Special Constants and Data types

#### SVGENDQ

The module definition is created as a data type. This makes it convenient to instance an interface to space vector generator. To create multiple instances of the module simply declare variables of type SVGENDQ.

#### SVGENDQ\_handle

User defined Data type of pointer to SVGENDQ module

#### SVGENDQ\_DEFAULTS

Structure symbolic constant to initialize SVGENDQ module. This provides the initial values to the terminal variables as well as method pointers.

## Methods

### SVGEN\_MACRO (SVGENDQ\_handle);

This definition implements one method viz., the space vector generator computation macro. The input argument to this macro is the module handle.

## Module Usage

### Instantiation

The following example instances two SVGENDQ objects  
SVGENDQ svgen\_dq1, svgen\_dq2;

### Initialization

To Instance pre-initialized objects  
SVGENDQ svgen\_dq1 = SVGENDQ\_DEFAULTS;  
SVGENDQ svgen\_dq2 = SVGENDQ\_DEFAULTS;

### Invoking the computation macro

SVGEN\_MACRO (svgen\_dq1);  
SVGEN\_MACRO (svgen\_dq2);

## Example

The following pseudo code provides the information about the module usage.

```
main()
{
}

void interrupt periodic_interrupt_isr()
{
    svgen_dq1.Ualpha = Ualpha1;           // Pass inputs to svgen_dq1
    svgen_dq1.Ubeta  = Ubeta1;           // Pass inputs to svgen_dq1

    svgen_dq2.Ualpha = Ualpha2;           // Pass inputs to svgen_dq2
    svgen_dq2.Ubeta  = Ubeta2;           // Pass inputs to svgen_dq2

    SVGEN_MACRO (svgen_dq1);             // Call compute macro for svgen_dq1
    SVGEN_MACRO (svgen_dq2);             // Call compute macro for svgen_dq2

    Ta1 = svgen_dq1.Ta;                   // Access the outputs of svgen_dq1
    Tb1 = svgen_dq1.Tb;                   // Access the outputs of svgen_dq1
    Tc1 = svgen_dq1.Tc;                   // Access the outputs of svgen_dq1

    Ta2 = svgen_dq2.Ta;                   // Access the outputs of svgen_dq2
    Tb2 = svgen_dq2.Tb;                   // Access the outputs of svgen_dq2
    Tc2 = svgen_dq2.Tc;                   // Access the outputs of svgen_dq2
}
```

**Technical Background**

The Space Vector Pulse Width Modulation (SVPWM) refers to a special switching sequence of the upper three power devices of a three-phase voltage source inverters (VSI) used in application such as AC induction and permanent magnet synchronous motor drives. This special switching scheme for the power devices results in 3 pseudo-sinusoidal currents in the stator phases.

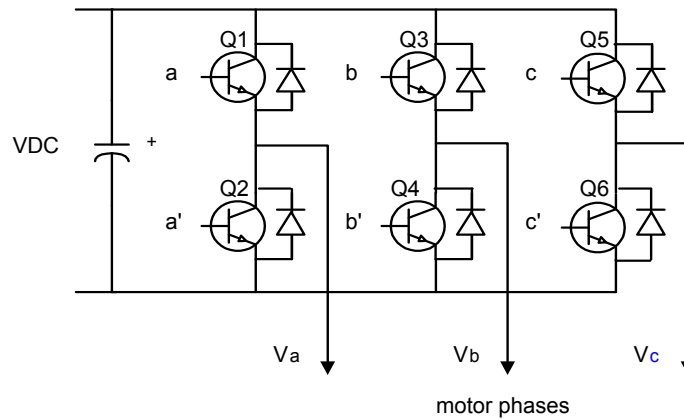

Figure 1 Power circuit topology for a three-phase VSI

It has been shown that SVPWM generates less harmonic distortion in the output voltages or currents in the windings of the motor load and provides more efficient use of DC supply voltage, in comparison to direct sinusoidal modulation technique.

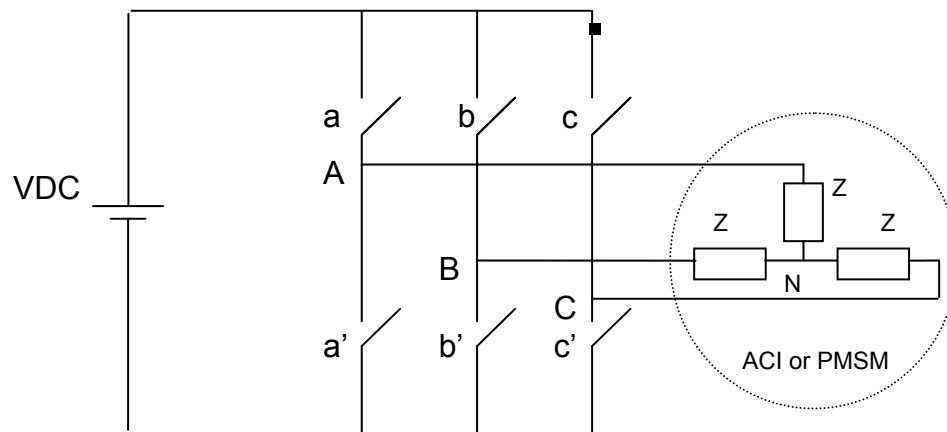

Figure 2: Power bridge for a three-phase VSI

For the three phase power inverter configurations shown in Figure 1 and Figure 2, there are eight possible combinations of on and off states of the upper power transistors. These combinations and the resulting instantaneous output line-to-line and phase voltages, for a dc bus voltage of  $V_{DC}$ , are shown in Table 1.

c	b	a	V <sub>AN</sub>	V <sub>BN</sub>	V <sub>CN</sub>	V <sub>AB</sub>	V <sub>BC</sub>	V <sub>CA</sub>
0	0	0	0	0	0	0	0	0
0	0	1	2V <sub>DC</sub> /3	-V <sub>DC</sub> /3	-V <sub>DC</sub> /3	V <sub>DC</sub>	0	-V <sub>DC</sub>
0	1	0	-V <sub>DC</sub> /3	2V <sub>DC</sub> /3	-V <sub>DC</sub> /3	-V <sub>DC</sub>	V <sub>DC</sub>	0
0	1	1	V <sub>DC</sub> /3	V <sub>DC</sub> /3	-2V <sub>DC</sub> /3	0	V <sub>DC</sub>	-V <sub>DC</sub>
1	0	0	-V <sub>DC</sub> /3	-V <sub>DC</sub> /3	2V <sub>DC</sub> /3	0	-V <sub>DC</sub>	V <sub>DC</sub>
1	0	1	V <sub>DC</sub> /3	-2V <sub>DC</sub> /3	V <sub>DC</sub> /3	V <sub>DC</sub>	-V <sub>DC</sub>	0
1	1	0	-2V <sub>DC</sub> /3	V <sub>DC</sub> /3	V <sub>DC</sub> /3	-V <sub>DC</sub>	0	V <sub>DC</sub>
1	1	1	0	0	0	0	0	0

Table 1. Device on/off patterns and resulting instantaneous voltages of a 3-phase power inverter

The quadrature quantities (in the (α,β) frame) corresponding to these 3 phase voltages are given by the general Clarke transform equation:

$$V_{s\alpha} = V_{AN}$$

$$V_{s\beta} = (2V_{BN} + V_{AN})/\sqrt{3}$$

In matrix form the above equation is also expressed as,

$$\begin{bmatrix} V_{s\alpha} \\ V_{s\beta} \end{bmatrix} = \frac{2}{3} \begin{bmatrix} 1 & -\frac{1}{2} & -\frac{1}{2} \\ 0 & \frac{\sqrt{3}}{2} & -\frac{\sqrt{3}}{2} \end{bmatrix} \begin{bmatrix} V_{AN} \\ V_{BN} \\ V_{CN} \end{bmatrix}$$

Due to the fact that only 8 combinations are possible for the power switches, V<sub>sα</sub> and V<sub>sβ</sub> can also take only a finite number of values in the (α,β) frame according to the status of the transistor command signals (c,b,a). These values of V<sub>sα</sub> and V<sub>sβ</sub> for the corresponding instantaneous values of the phase voltages (V<sub>AN</sub>, V<sub>BN</sub>, V<sub>CN</sub>) are listed in Table 2.

c	b	a	$V_{s\alpha}$	$V_{s\beta}$	Vector
0	0	0	0	0	$O_0$
0	0	1	$\frac{2}{3}V_{DC}$	0	$U_0$
0	1	0	$-\frac{V_{DC}}{3}$	$\frac{V_{DC}}{\sqrt{3}}$	$U_{120}$
0	1	1	$\frac{V_{DC}}{3}$	$\frac{V_{DC}}{\sqrt{3}}$	$U_{60}$
1	0	0	$-\frac{V_{DC}}{3}$	$-\frac{V_{DC}}{\sqrt{3}}$	$U_{240}$
1	0	1	$\frac{V_{DC}}{3}$	$-\frac{V_{DC}}{\sqrt{3}}$	$U_{300}$
1	1	0	$-\frac{2}{3}V_{DC}$	0	$U_{180}$
1	1	1	0	0	$O_{111}$

Table 2: Switching patterns, corresponding space vectors and their  $(\alpha,\beta)$  components

These values of  $V_{s\alpha}$  and  $V_{s\beta}$ , listed in Table 2, are called the  $(\alpha,\beta)$  components of the basic space vectors corresponding to the appropriate transistor command signal (c,b,a). The space vectors corresponding to the signal (c,b,a) are listed in the last column in Table 2. For example, (c,b,a)=001 indicates that the space vector is  $U_0$ . The eight basic space vectors defined by the combination of the switches are also shown in Figure 3.

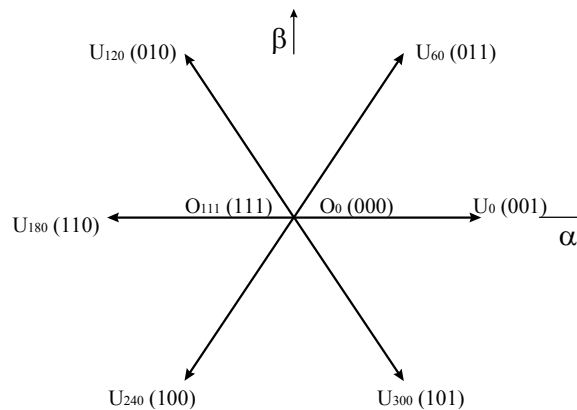

Figure 3: Basic space vectors

Projection of the stator reference voltage vector  $U_{out}$

The objective of Space Vector PWM technique is to approximate a given stator reference voltage vector  $U_{out}$  by combination of the switching pattern corresponding to the basic space vectors. The reference vector  $U_{out}$  is represented by its  $(\alpha, \beta)$  components,  $U_{\alpha}$  and  $U_{\beta}$ . Figure 4 shows the reference voltage vector, its  $(\alpha, \beta)$  components and two of the basic space vectors,  $U_0$  and  $U_{60}$ . The figure also indicates the resultant  $\alpha$  and  $\beta$  components for the space vectors  $U_0$  and  $U_{60}$ .  $\Sigma V_{s\beta}$  represents the sum of the  $\beta$  components of  $U_0$  and  $U_{60}$ , while  $\Sigma V_{s\alpha}$  represents the sum of the  $\alpha$  components of  $U_0$  and  $U_{60}$ . Therefore,

$$\begin{cases} \sum V_{s\beta} = 0 + \frac{V_{DC}}{\sqrt{3}} = \frac{V_{DC}}{\sqrt{3}} \\ \sum V_{s\alpha} = \frac{2V_{DC}}{3} + \frac{V_{DC}}{3} = V_{DC} \end{cases}$$

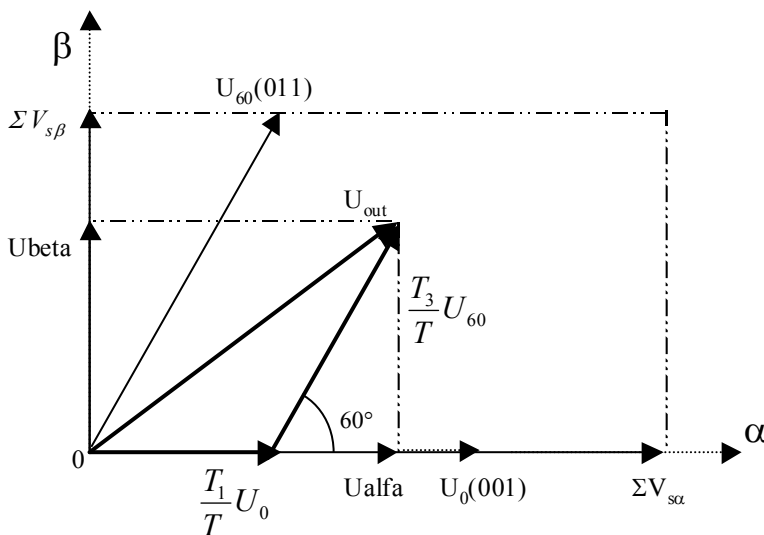

Figure 4: Projection of the reference voltage vector

For the case in Figure 4, the reference vector  $U_{out}$  is in the sector contained by  $U_0$  and  $U_{60}$ . Therefore  $U_{out}$  is represented by  $U_0$  and  $U_{60}$ . So we can write,

$$\begin{cases} T = T_1 + T_3 + T_0 \\ U_{out} = \frac{T_1}{T}U_0 + \frac{T_3}{T}U_{60} \end{cases}$$

where,  $T_1$  and  $T_3$  are the respective durations in time for which  $U_0$  and  $U_{60}$  are applied within period  $T$ .  $T_0$  is the time duration for which the null vector is applied. These time durations can be calculated as follows:

$$\begin{cases} U_{beta} = \frac{T_3}{T} |U_{60}| \sin(60^\circ) \\ U_{alfa} = \frac{T_1}{T} |U_0| + \frac{T_3}{T} |U_{60}| \cos(60^\circ) \end{cases}$$

From Table 2 and Figure 4 it is evident that the magnitude of all the space vectors is  $2V_{DC}/3$ . When this is normalized by the maximum phase voltage(line to neutral),  $V_{DC}/\sqrt{3}$ , the magnitude of the space vectors become  $2/\sqrt{3}$  i.e., the normalized magnitudes are  $|U_0| = |U_{60}| = 2/\sqrt{3}$ . Therefore, from the last two equations the time durations are calculated as,

$$T_1 = \frac{T}{2} (\sqrt{3}U_{alfa} - U_{beta})$$

$$T_3 = TU_{beta}$$

Where,  $U_{alpha}$  and  $U_{beta}$  also represent the normalized ( $\alpha, \beta$ ) components of  $U_{out}$  with respect to the maximum phase voltage( $V_{DC}/\sqrt{3}$ ). The rest of the period is spent in applying the null vector  $T_0$ . The time durations, as a fraction of the total  $T$ , are given by,

$$t1 = \frac{T_1}{T} = \frac{1}{2} (\sqrt{3}U_{alfa} - U_{beta})$$

$$t2 = \frac{T_3}{T} = U_{beta}$$

In a similar manner, if  $U_{out}$  is in sector contained by  $U_{60}$  and  $U_{120}$ , then by knowing

$|U_{60}| = |U_{120}| = 2/\sqrt{3}$  (normalized with respect to  $V_{DC}/\sqrt{3}$ ), the time durations can be derived as,

$$t1 = \frac{T_2}{T} = \frac{1}{2} (-\sqrt{3}U_{alfa} + U_{beta})$$

$$t2 = \frac{T_3}{T} = \frac{1}{2} (\sqrt{3}U_{alfa} + U_{beta})$$

where,  $T_2$  is the duration in time for which  $U_{120}$  is applied within period  $T$

Now, if we define 3 variables  $X$ ,  $Y$  and  $Z$  according to the following equations,

$$X = U_{beta}$$

$$Y = \frac{1}{2} (\sqrt{3}U_{alfa} + U_{beta})$$

$$Z = \frac{1}{2} (-\sqrt{3}U_{alfa} + U_{beta})$$

Then for the first example, when  $U_{out}$  is in sector contained by  $U_0$  and  $U_{60}$ ,  $t1 = -Z$ ,  $t2 = X$ .

For the second example, when  $U_{out}$  is in sector contained by  $U_{60}$  and  $U_{120}$ ,  $t1 = Z$ ,  $t2 = Y$ .



In a similar manner t1 and t2 can be calculated for the cases when  $U_{out}$  is in sectors contained by other space vectors. For different sectors the expressions for t1 and t2 in terms of X, Y and Z are listed in Table 3.

Sector	$U_0, U_{60}$	$U_{60}, U_{120}$	$U_{120}, U_{180}$	$U_{180}, U_{240}$	$U_{240}, U_{300}$	$U_{300}, U_0$
t1	-Z	Z	X	-X	-Y	Y
t2	X	Y	Y	Z	-Z	-X

Table 3: t1 and t2 definitions for different sectors in terms of X, Y and Z variables

In order to know which of the above variables apply, the knowledge of the sector containing the reference voltage vector is needed. This is achieved by first converting the  $(\alpha, \beta)$  components of the reference vector  $U_{out}$  into a balanced three phase quantities. That is,  $U_{alpha}$  and  $U_{beta}$  are converted to a balanced three phase quantities  $V_{ref1}$ ,  $V_{ref2}$  and  $V_{ref3}$  according to the following inverse clarke transformation:

$$\begin{cases} V_{ref1} = U_{beta} \\ V_{ref2} = \frac{-U_{beta} + U_{alfa} \times \sqrt{3}}{2} \\ V_{ref3} = \frac{-U_{beta} - U_{alfa} \times \sqrt{3}}{2} \end{cases}$$

Note that, this transformation projects the quadrature or  $\beta$  component,  $U_{beta}$ , into  $V_{ref1}$ . This means that the voltages  $V_{ref1}$ ,  $V_{ref2}$  and  $V_{ref3}$  are all phase advanced by  $90^\circ$  when compared to the corresponding voltages generated by the conventional inverse clarke transformation which projects the  $\alpha$  component,  $U_{alpha}$ , into phase voltage  $V_{AN}$ . The following equations describe the  $(\alpha, \beta)$  components and the reference voltages:

$$\begin{cases} U_{alfa} = \sin \omega t \\ U_{beta} = \cos \omega t \\ V_{ref1} = \cos \omega t \\ V_{ref2} = \cos(\omega t - 120^\circ) \\ V_{ref3} = \cos(\omega t + 120^\circ) \end{cases}$$

Note that, the above voltages are all normalized by the maximum phase voltage ( $V_{DC}/\sqrt{3}$ ).

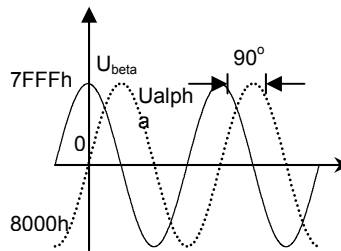

Figure 5: ( $\alpha, \beta$ ) components of stator reference voltage

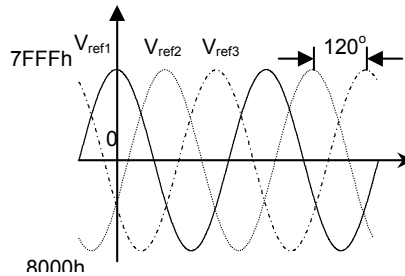

Figure 6: Voltages  $V_{ref1}$ ,  $V_{ref2}$  and  $V_{ref3}$

From the last three equations the following decisions can be made on the sector information:

If  $V_{ref1} > 0$  then  $a=1$ , else  $a=0$

If  $V_{ref2} > 0$  then  $b=1$ , else  $b=0$

If  $V_{ref3} > 0$  then  $c=1$ , else  $c=0$

The variable *sector* in the code is defined as,  $sector = 4*c+2*b+a$

For example, in Figure 3  $a=1$  for the vectors  $U_{300}$ ,  $U_0$  and  $U_{60}$ . For these vectors the phase of  $V_{ref1}$  are  $\omega t=300^\circ$ ,  $\omega t=0$  and  $\omega t=60^\circ$  respectively. Therefore,  $V_{ref1} > 0$  when  $a=1$ .

The ( $\alpha, \beta$ ) components,  $U_{alpha}$  and  $U_{beta}$ , defined above represent the output phase voltages  $V_{AN}$ ,  $V_{BN}$  and  $V_{CN}$ . The following equations describe these phase voltages:

$$\begin{cases} V_{AN} = \sin \omega t \\ V_{BN} = \sin(\omega t + 120^\circ) \\ V_{CN} = \sin(\omega t - 120^\circ) \end{cases}$$

The Space Vector PWM module is divided in several parts:

- Determination of the sector
- Calculation of X, Y and Z
- Calculation of  $t_1$  and  $t_2$
- Determination of the duty cycle  $t_{aon}$ ,  $t_{bon}$  and  $t_{con}$
- Assignment of the duty cycles to  $T_a$ ,  $T_b$  and  $T_c$

The variables  $t_{aon}$ ,  $t_{bon}$  and  $t_{con}$  are calculated using the following equations:

$$\begin{cases} t_{aon} = \frac{PWMPRD - t_1 - t_2}{2} \\ t_{bon} = t_{aon} + t_1 \\ t_{con} = t_{bon} + t_2 \end{cases}$$

Then the right duty cycle (txon) is assigned to the right motor phase (in other words, to Ta, Tb and Tc) according to the sector. Table 4 depicts this determination.

sectors	U <sub>0</sub> , U <sub>60</sub>	U <sub>60</sub> , U <sub>120</sub>	U <sub>120</sub> , U <sub>180</sub>	U <sub>180</sub> , U <sub>240</sub>	U <sub>240</sub> , U <sub>300</sub>	U <sub>300</sub> , U <sub>0</sub>
Ta	taon	tbon	tcon	tcon	tbon	taon
Tb	tbon	taon	taon	tbon	tcon	tcon
Tc	tcon	tcon	tbon	taon	taon	tbon

Table 4: Table Assigning the Right Duty Cycle to the Right Motor Phase

Example: Sector contained by U<sub>0</sub> and U<sub>60</sub>.

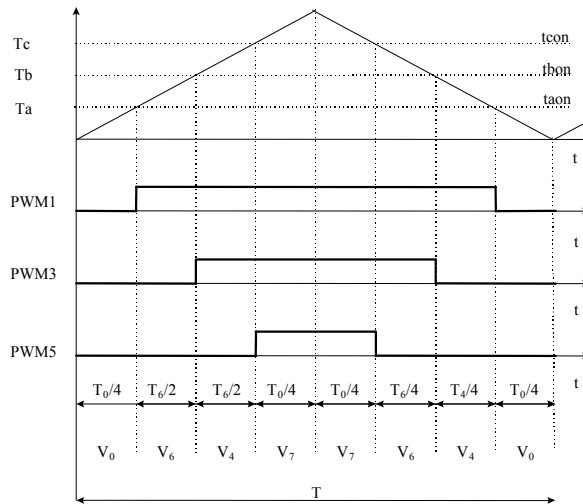

Figure 7: PWM Patterns and Duty Cycles for sector contained by U<sub>0</sub> and U<sub>60</sub>

Next, Table 5 shows the correspondence of notations between variables used here and variables used in the program (i.e., svgen\_dq.c, svgen\_dq.h). The software module requires that both input and output variables are in per unit values.

	<b>Equation Variables</b>	<b>Program Variables</b>
<b>Inputs</b>	Ualpha	Ualpha
	Ubeta	Ubeta
<b>Outputs</b>	Ta	Ta
	Tb	Tb
	Tc	Tc
<b>Others</b>	$V_{ref1}$	Va
	$V_{ref2}$	Vb
	$V_{ref3}$	Vc

Table 5: Correspondence of notations