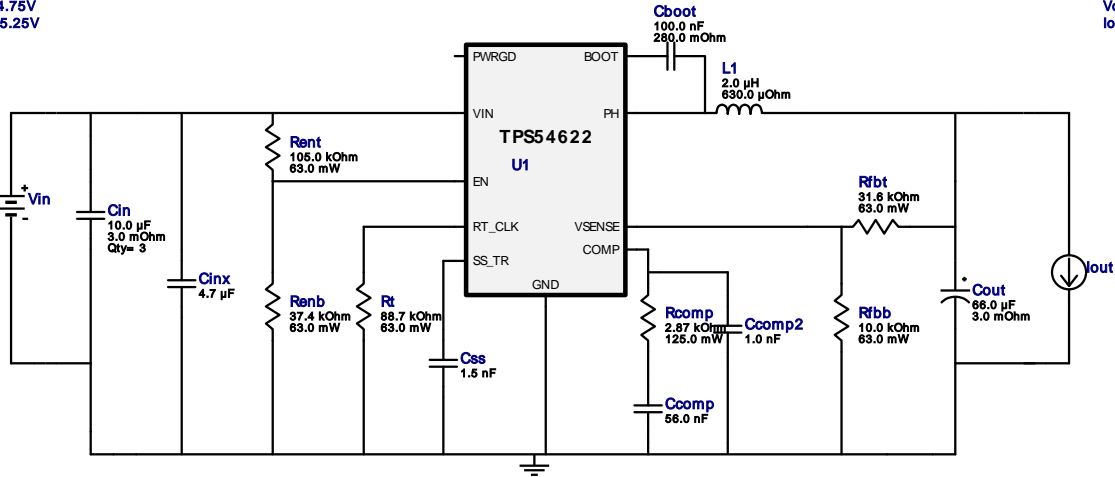

WEBENCH® Design Report

 Design : 1225200/3003 TPS54622RHLLR
 TPS54622RHLLR 4.75V-5.25V to 2.5V @ 4.75A

 VinMin = 4.75V
 VinMax = 5.25V

 Vout = 2.5V
 Iout = 4.75A

Electrical BOM

#	Name	Manufacturer	Part Number	Properties	Qty	Price	Footprint
1.	Cboot	AVX	08053C104KAT2A Series= X7R	Cap= 100.0 nF ESR= 280.0 mOhm VDC= 25.0 V IRMS= 0.0 A	1	\$0.01	0805 7mm2
2.	Ccomp	MuRata	GRM155R61A563KA01D Series= X5R	Cap= 56.0 nF VDC= 10.0 V IRMS= 0.0 A	1	\$0.01	0402 3mm2
3.	Ccomp2	Yageo America	CC0805KRX7R9BB102 Series= X7R	Cap= 1.0 nF VDC= 50.0 V IRMS= 0.0 A	1	\$0.01	0805 7mm2
4.	Cin	Kemet	C0805C106K8PACTU Series= X5R	Cap= 10.0 µF ESR= 3.0 mOhm VDC= 10.0 V IRMS= 11.43 A	3	\$0.04	0805 7mm2
5.	Cinx	MuRata	GRM21BC81E475KA12L Series= 379	Cap= 4.7 µF VDC= 25.0 V IRMS= 0.0 A	1	\$0.04	0805 7mm2
6.	Cout	CUSTOM	CUSTOM Series= CUSTOM	Cap= 66.0 µF ESR= 3.0 mOhm VDC= 6.3 V IRMS= 3.9 A	1	\$0.10	CUSTOM 1mm2
7.	Css	Yageo America	CC0805KRX7R9BB152 Series= X7R	Cap= 1.5 nF VDC= 50.0 V IRMS= 0.0 A	1	\$0.01	0805 7mm2
8.	L1	CUSTOM	CUSTOM	L= 2.0 µH DCR= 630.0 µOhm	1	\$0.10	CUSTOM 29mm2
9.	Rcomp	Panasonic	ERJ-6ENF2871V Series= 225	Res= 2.87 kOhm Power= 125.0 mW Tolerance= 1.0%	1	\$0.01	0805 7mm2
10.	Renb	Vishay-Dale	CRCW040237K4FKED Series= CRCW..e3	Res= 37.4 kOhm Power= 63.0 mW Tolerance= 1.0%	1	\$0.01	0402 3mm2
11.	Rent	Vishay-Dale	CRCW0402105KFKED Series= CRCW..e3	Res= 105.0 kOhm Power= 63.0 mW Tolerance= 1.0%	1	\$0.01	0402 3mm2

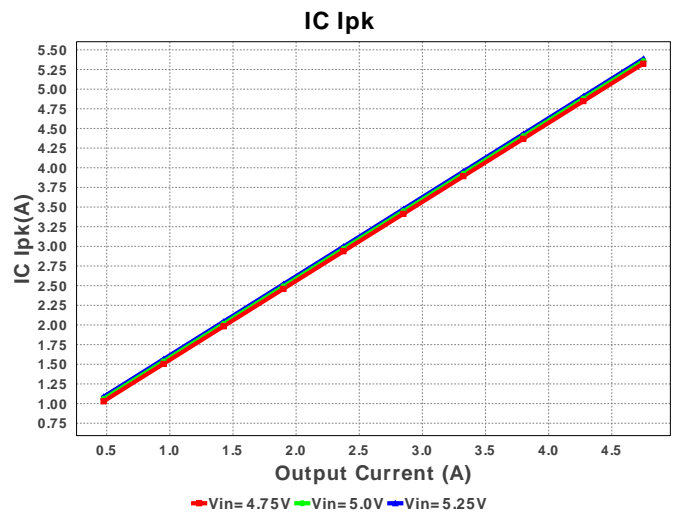
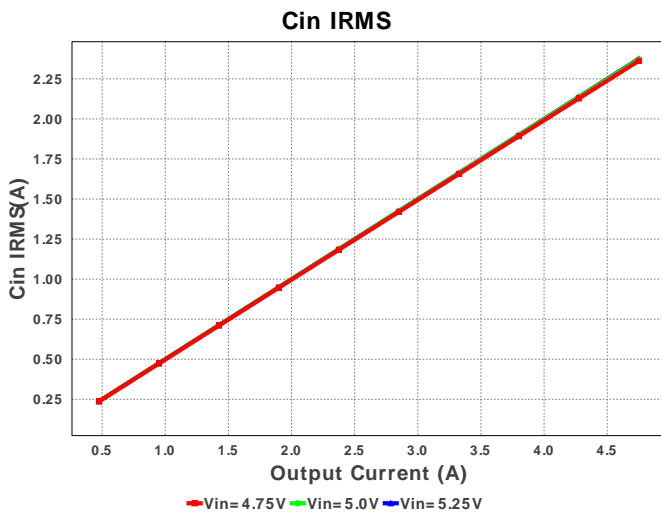
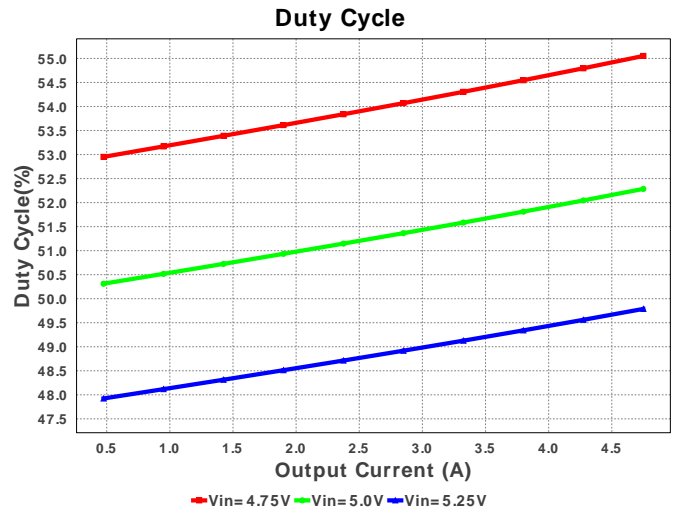
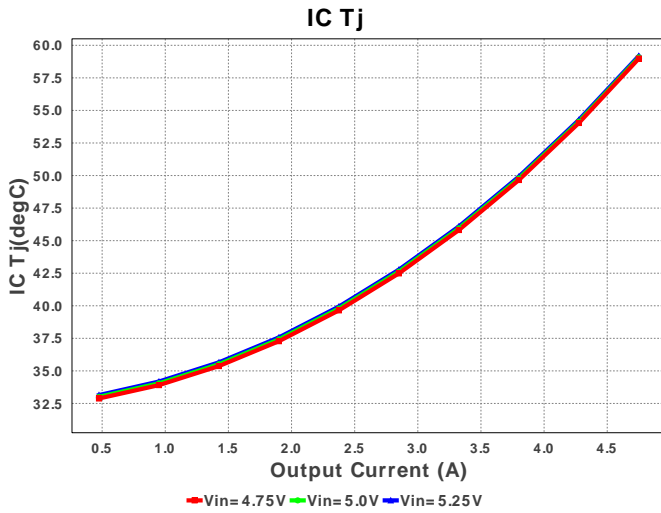
#	Name	Manufacturer	Part Number	Properties	Qty	Price	Footprint
12.	Rfbb	Vishay-Dale	CRCW040210K0FKED Series= CRCW..e3	Res= 10.0 kOhm Power= 63.0 mW Tolerance= 1.0%	1	\$0.01	0402 3mm2
13.	Rfbt	Vishay-Dale	CRCW040231K6FKED Series= CRCW..e3	Res= 31.6 kOhm Power= 63.0 mW Tolerance= 1.0%	1	\$0.01	0402 3mm2
14.	Rt	Vishay-Dale	CRCW040288K7FKED Series= CRCW..e3	Res= 88.7 kOhm Power= 63.0 mW Tolerance= 1.0%	1	\$0.01	0402 3mm2
15.	U1	Texas Instruments	TPS54622RHLR	Switcher	1	\$2.50	S-PVQFN-N14 22mm2

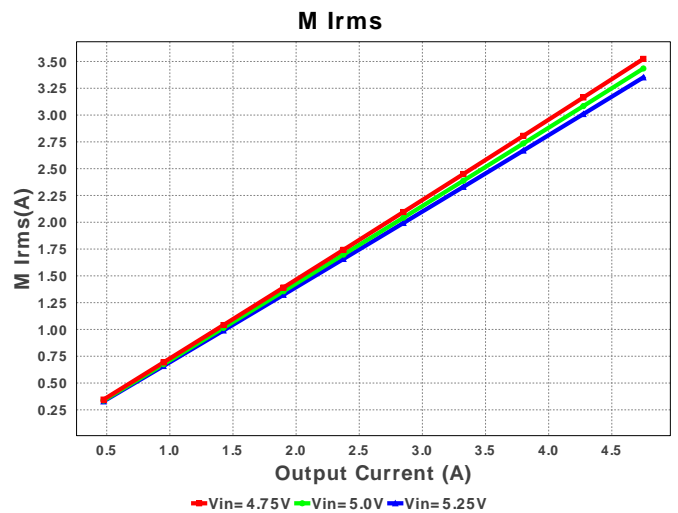
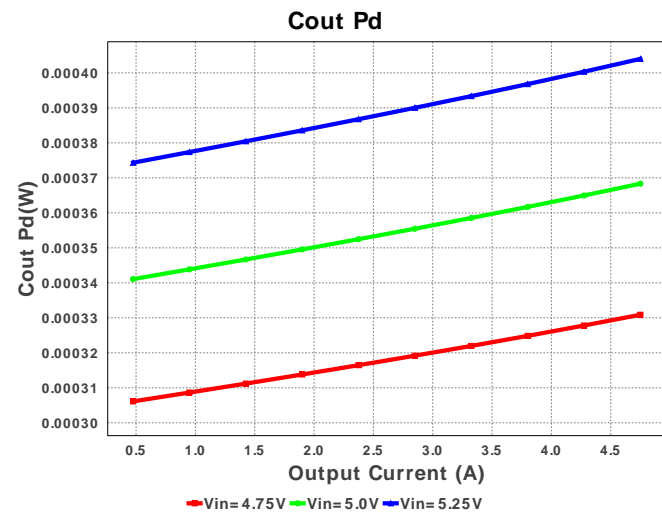
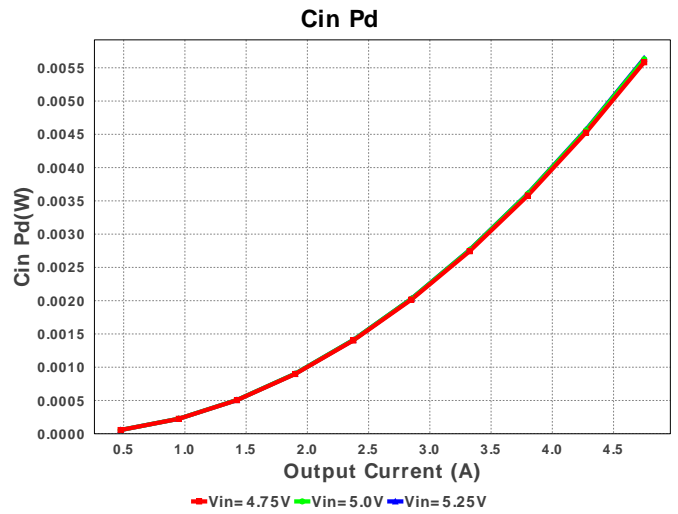
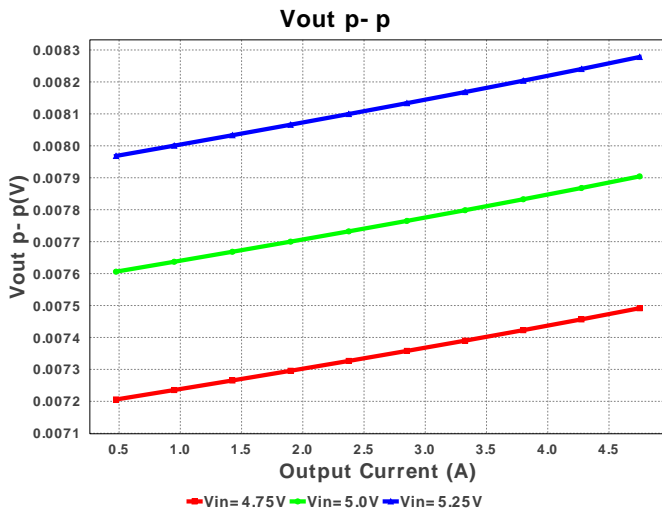
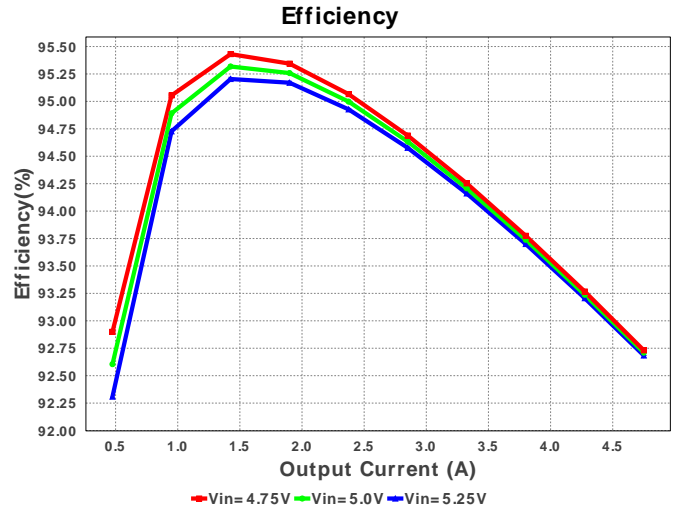
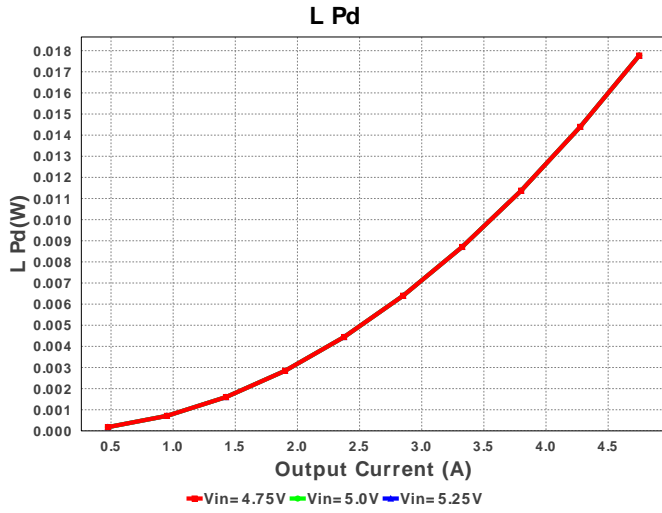

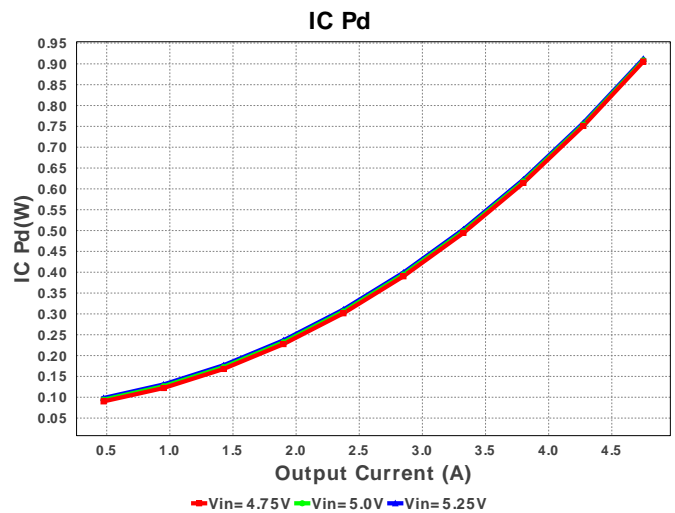
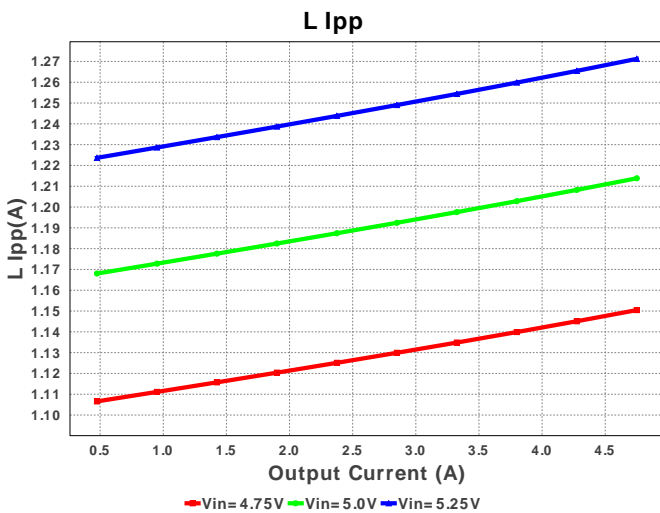
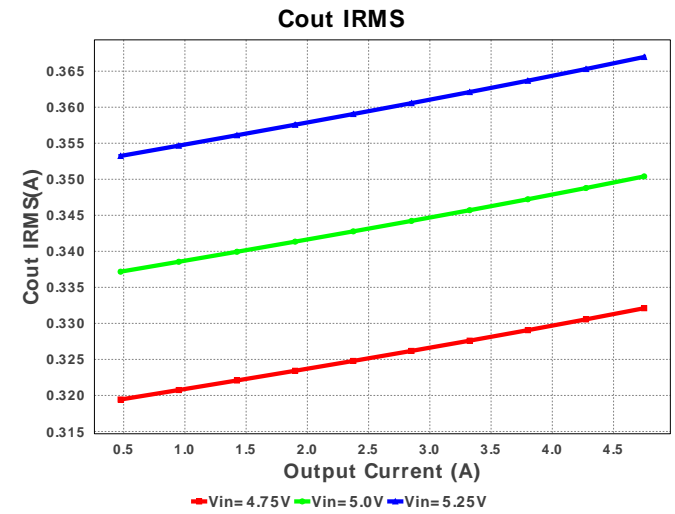
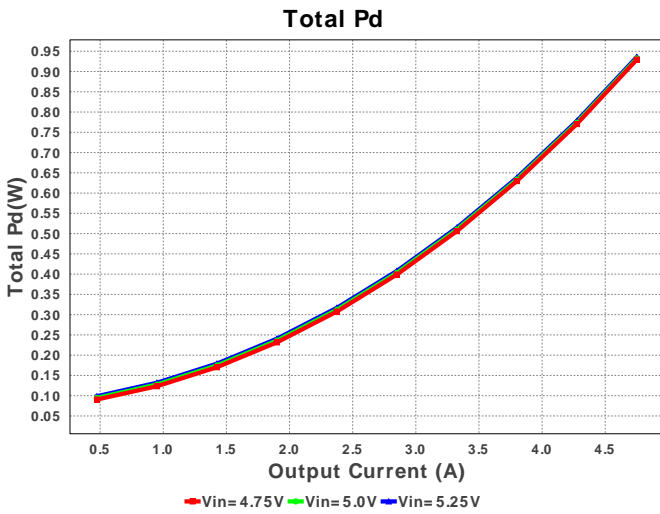
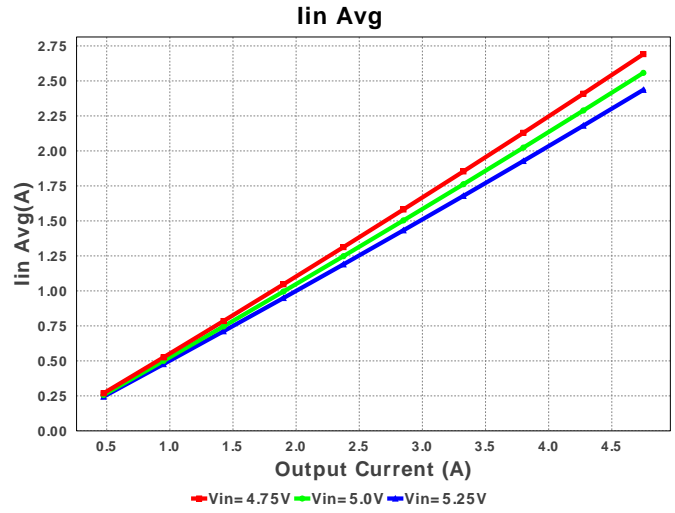
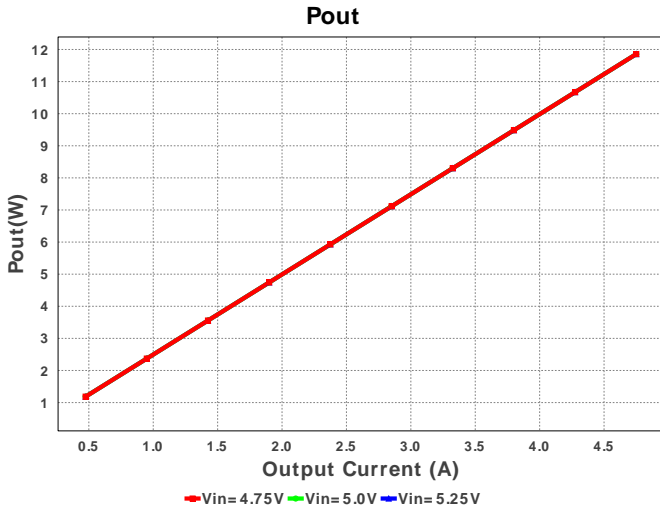



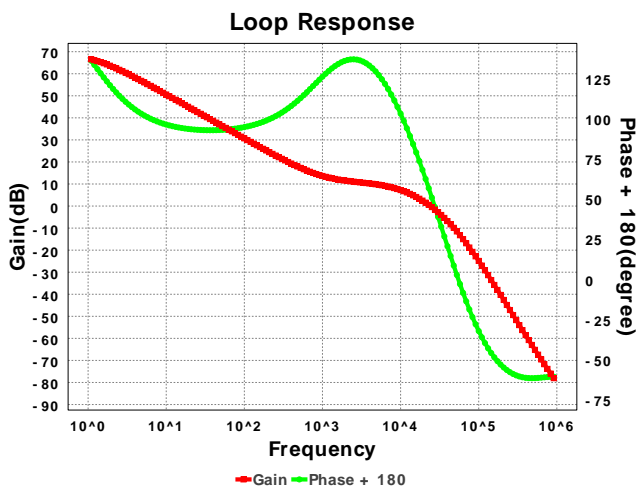
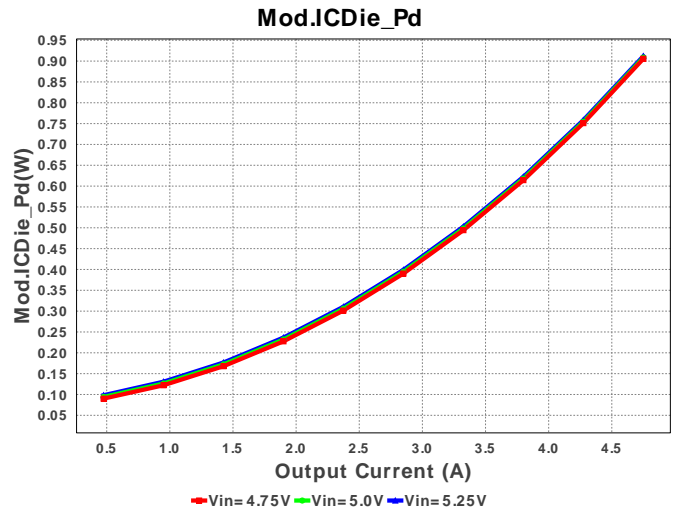
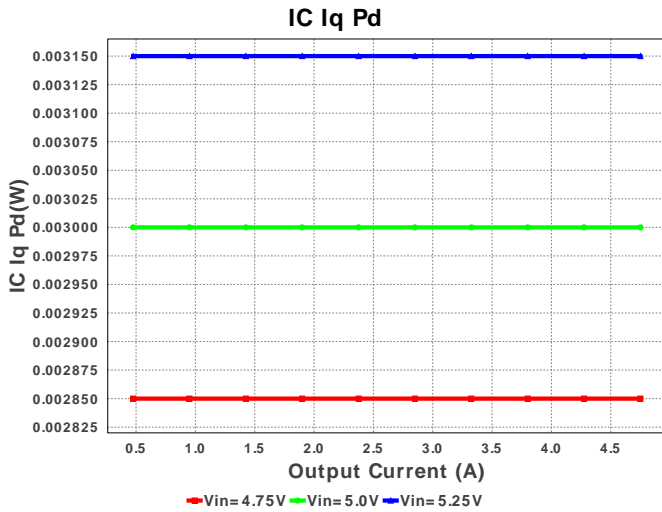

Operating Values

#	Name	Value	Category	Description
1.	BOM Count	17		Total Design BOM count
2.	Total BOM	\$2.96		Total BOM Cost
3.	Cin IRMS	2.375 A	Current	Input capacitor RMS ripple current
4.	Cout IRMS	366.973 mA	Current	Output capacitor RMS ripple current
5.	IC Ipk	5.386 A	Current	Peak switch current in IC
6.	Iin Avg	2.436 A	Current	Average input current
7.	L Ipp	1.271 A	Current	Peak-to-peak inductor ripple current
8.	M1 Irms	3.352 A	Current	Q Iavg
9.	FootPrint	166.0 mm2	General	Total Foot Print Area of BOM components
10.	Frequency	539.299 kHz	General	Switching frequency
11.	IC Tolerance	10.0 mV	General	IC Feedback Tolerance
12.	Pout	11.856 W	General	Total output power
13.	Vout OP	2.496 V	Op_Point	Operational Output Voltage
14.	Cross Freq	24.119 kHz	Op_point	Bode plot crossover frequency
15.	Duty Cycle	49.787 %	Op_point	Duty cycle
16.	Efficiency	92.684 %	Op_point	Steady state efficiency
17.	IC Tj	59.183 degC	Op_point	IC junction temperature
18.	ICThetaJA	32.0 degC/W	Op_point	IC junction-to-ambient thermal resistance
19.	IOUT_OP	4.75 A	Op_point	Iout operating point
20.	Phase Marg	54.255 deg	Op_point	Bode Plot Phase Margin
21.	VIN_OP	5.25 V	Op_point	Vin operating point
22.	Vout p-p	8.278 mV	Op_point	Peak-to-peak output ripple voltage
23.	Cin Pd	5.641 mW	Power	Input capacitor power dissipation
24.	Cout Pd	404.007 μW	Power	Output capacitor power dissipation
25.	IC Iq Pd	3.15 mW	Power	IC Iq Pd
26.	IC Pd	911.971 mW	Power	IC power dissipation
27.	L Pd	17.768 mW	Power	Inductor power dissipation
28.	Total Pd	935.835 mW	Power	Total Power Dissipation

Design Inputs

#	Name	Value	Description
1.	Iout	4.75 A	Maximum Output Current
2.	Iout1	4.75 Amps	Output Current #1
3.	SoftStart	0.5 ms	Soft Start Time (ms)
4.	VinMax	5.25 V	Maximum input voltage
5.	VinMin	4.75 V	Minimum input voltage
6.	Vout	2.5 V	Output Voltage
7.	Vout1	2.5 Volt	Output Voltage #1
8.	base_pn	TPS54622	Base Product Number
9.	source	DC	Input Source Type
10.	Ta	30.0 degC	Ambient temperature
11.	UserFsw	550.0 kHz	Customer Selected Frequency

Design Assistance

1. **TPS54622** Product Folder : <http://www.ti.com/product/tps54622> : contains the data sheet and other resources.

Texas Instruments' WEBENCH simulation tools attempt to recreate the performance of a substantially equivalent physical implementation of the design. Simulations are created using Texas Instruments' published specifications as well as the published specifications of other device manufacturers. While Texas Instruments does update this information periodically, this information may not be current at the time the simulation is built. Texas Instruments does not warrant the accuracy or completeness of the specifications or any information contained therein. Texas Instruments does not warrant that any designs or recommended parts will meet the specifications you entered, will be suitable for your application or fit for any particular purpose, or will operate as shown in the simulation in a physical implementation. Texas Instruments does not warrant that the designs are production worthy.

You should completely validate and test your design implementation to confirm the system functionality for your application prior to production.

Use of Texas Instruments' WEBENCH simulation tools is subject to [Texas Instruments' Site Terms and Conditions of Use](#). Prototype boards based on WEBENCH created designs are provided AS IS without warranty of any kind for evaluation and testing purposes and are subject to the terms of the [Evaluation License Agreement](#).