

Close to MSP430

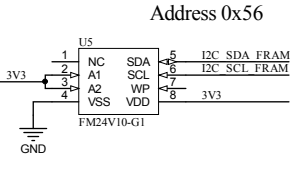

Close to MSP430

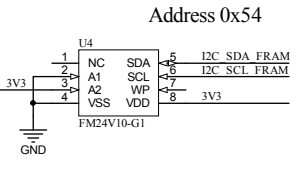
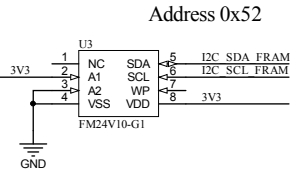
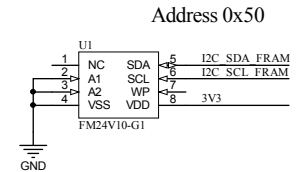
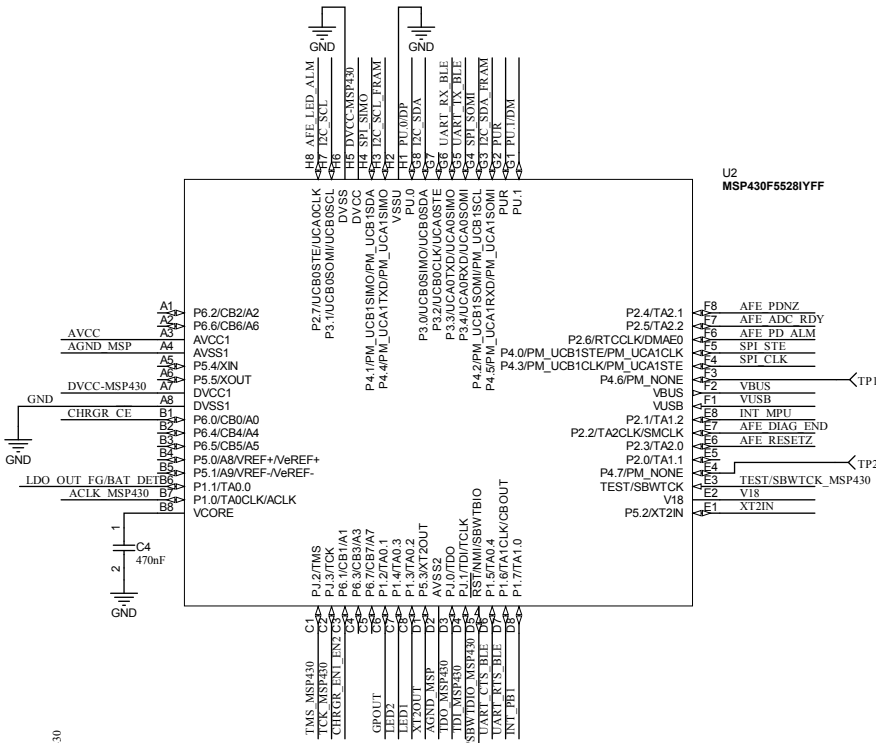
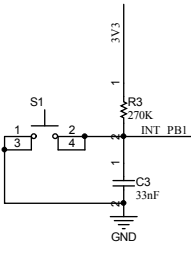
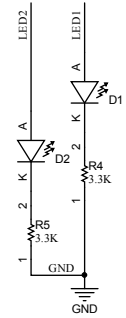
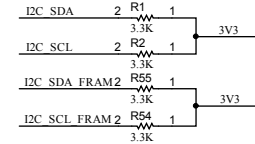
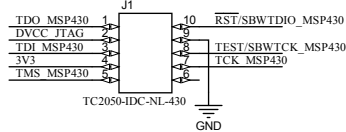
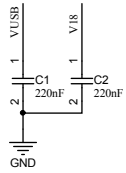
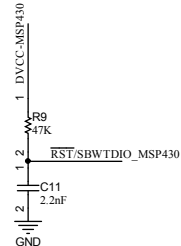
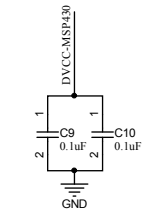
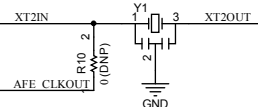
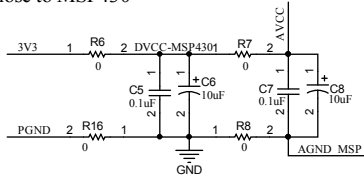

Decoupling Caps

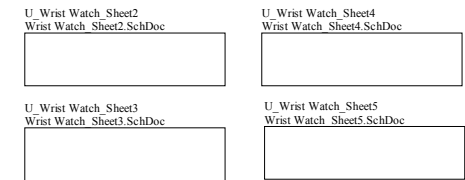

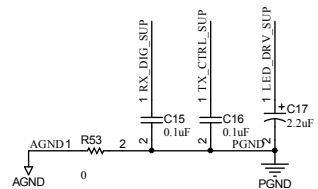
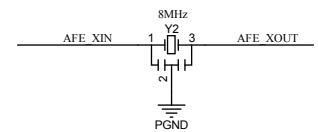
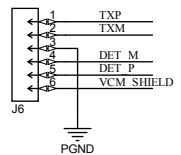
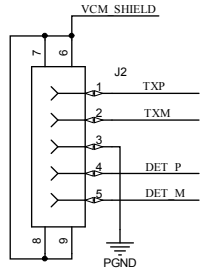
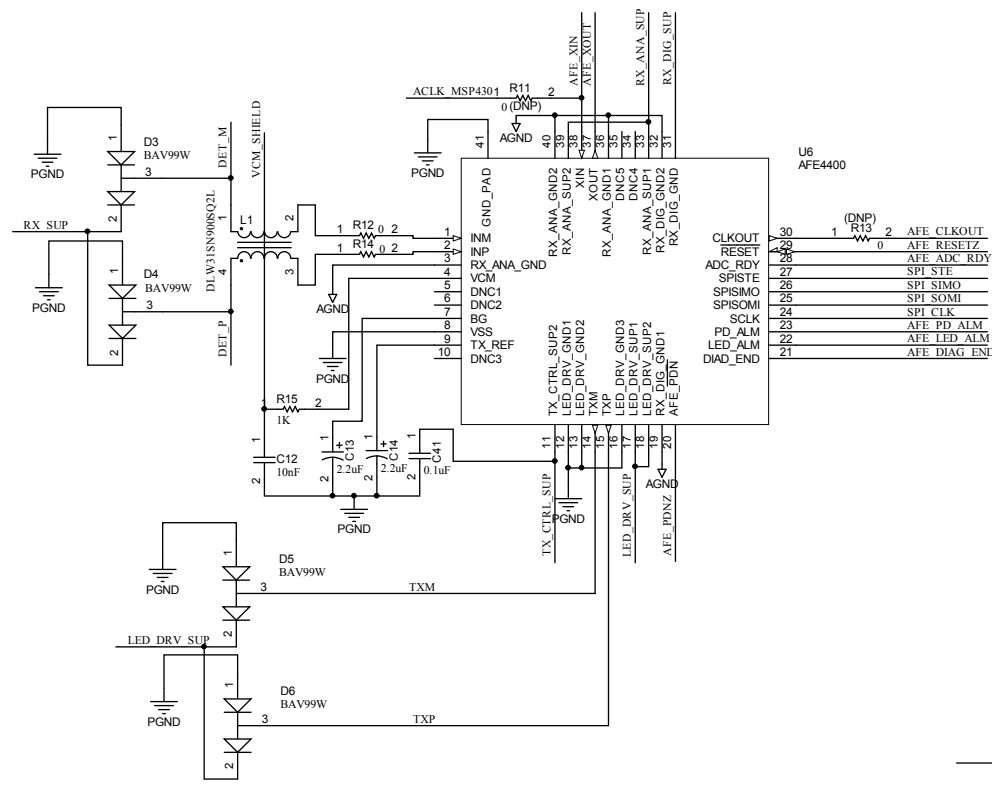

Texas Instruments and/or its licensors do not warrant the accuracy or completeness of this specification or any information contained therein. Texas Instruments and/or its licensors do not warrant that this design will meet the specifications, will be suitable for your application or fit for any particular purpose, or will operate in an implementation. Texas Instruments and/or its licensors do not warrant that the design is production worthy. You should completely validate and test your design implementation to confirm the system functionality for your application.

Designed for: Public Release		Mod. Date: 1/25/2013	
Project: Wrist Watch			
Sheet Title: ChangeMe		Sheet 2 of 5	
Size: A3	Schematic: 870Wrist Watch	Rev. Rev B	
Assembly Variant: Variant name not interpreted			
File: Wrist Watch_Sheet2_SchDoc			
Contact: <a href="http://www.ti.com/support">http://www.ti.com/support</a>			



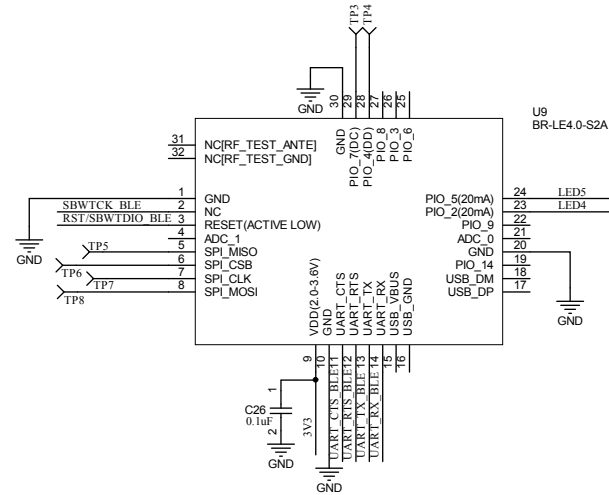

BT/BLE MODULE SPY-BY-WIRE

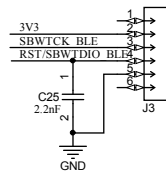

Address 0xXXXX

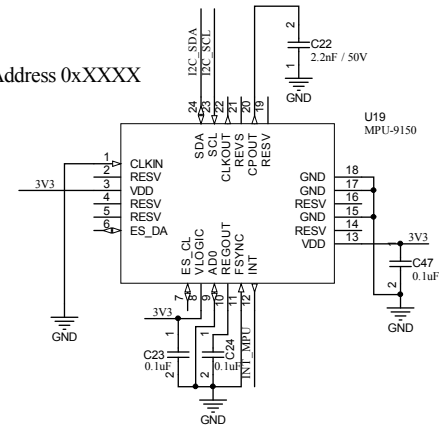

STATE

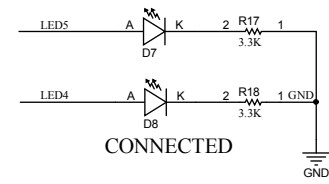

Texas Instruments and/or its licensors do not warrant the accuracy or completeness of this specification or any information contained therein. Texas Instruments and/or its licensors do not warrant that this design will meet the specifications, will be suitable for your application or fit for any particular purpose, or will operate in an implementation. Texas Instruments and/or its licensors do not warrant that the design is production worthy. You should completely validate and test your design implementation to confirm the system functionality for your application.

Designed for: Public Release	Mod. Date: 1/25/2013
Project: Wrist Watch	
Sheet Title: Wrist Watch	Sheet 3 of 5
Size: A3	Schematic: 870Wrist Watch
Assembly Variant: Variant name not interpreted	Rev: Rev B
File: Wrist Watch_Sheet3.SchDoc	
Contact: <a href="http://www.ti.com/support">http://www.ti.com/support</a>	



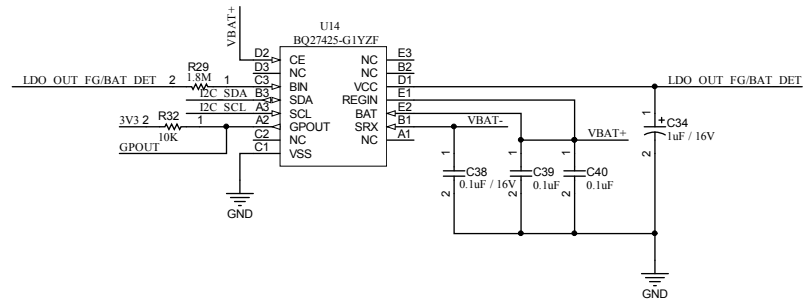
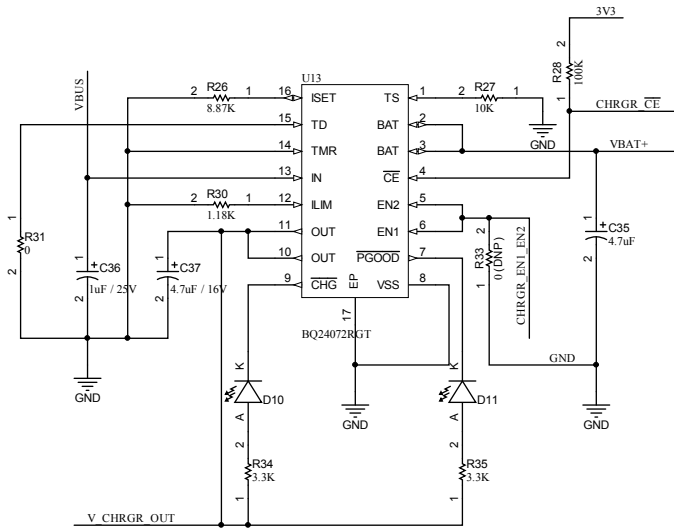
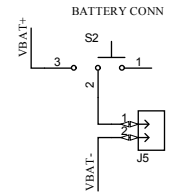
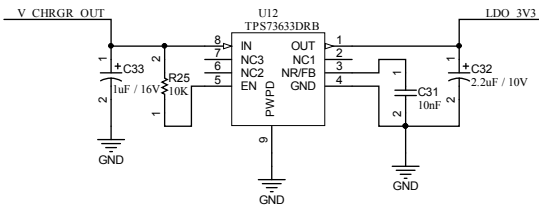
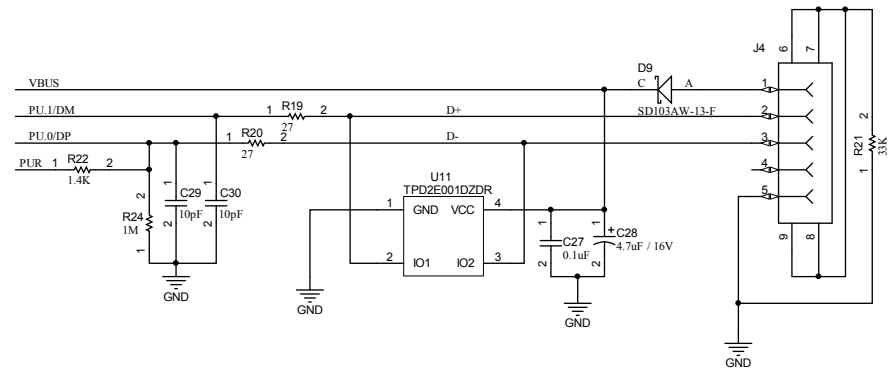
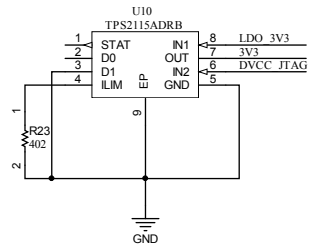

Texas Instruments and/or its licensors do not warrant the accuracy or completeness of this specification or any information contained therein. Texas Instruments and/or its licensors do not warrant that this design will meet the specifications, will be suitable for your application or fit for any particular purpose, or will operate in an implementation. Texas Instruments and/or its licensors do not warrant that the design is production worthy. You should completely validate and test your design implementation to confirm the system functionality for your application.

Designed for: Public Release	Mod. Date: 1/25/2013
Project: Wrist Watch	
Sheet Title: ChangeMe	Sheet 4 of 5
Size: A3	Schematic: 870Wrist Watch
Assembly Variant: Variant name not interpreted	Rev: Rev B
File: Wrist Watch Sheet4.SchDoc	
Contact: <a href="http://www.ti.com/support">http://www.ti.com/support</a>	



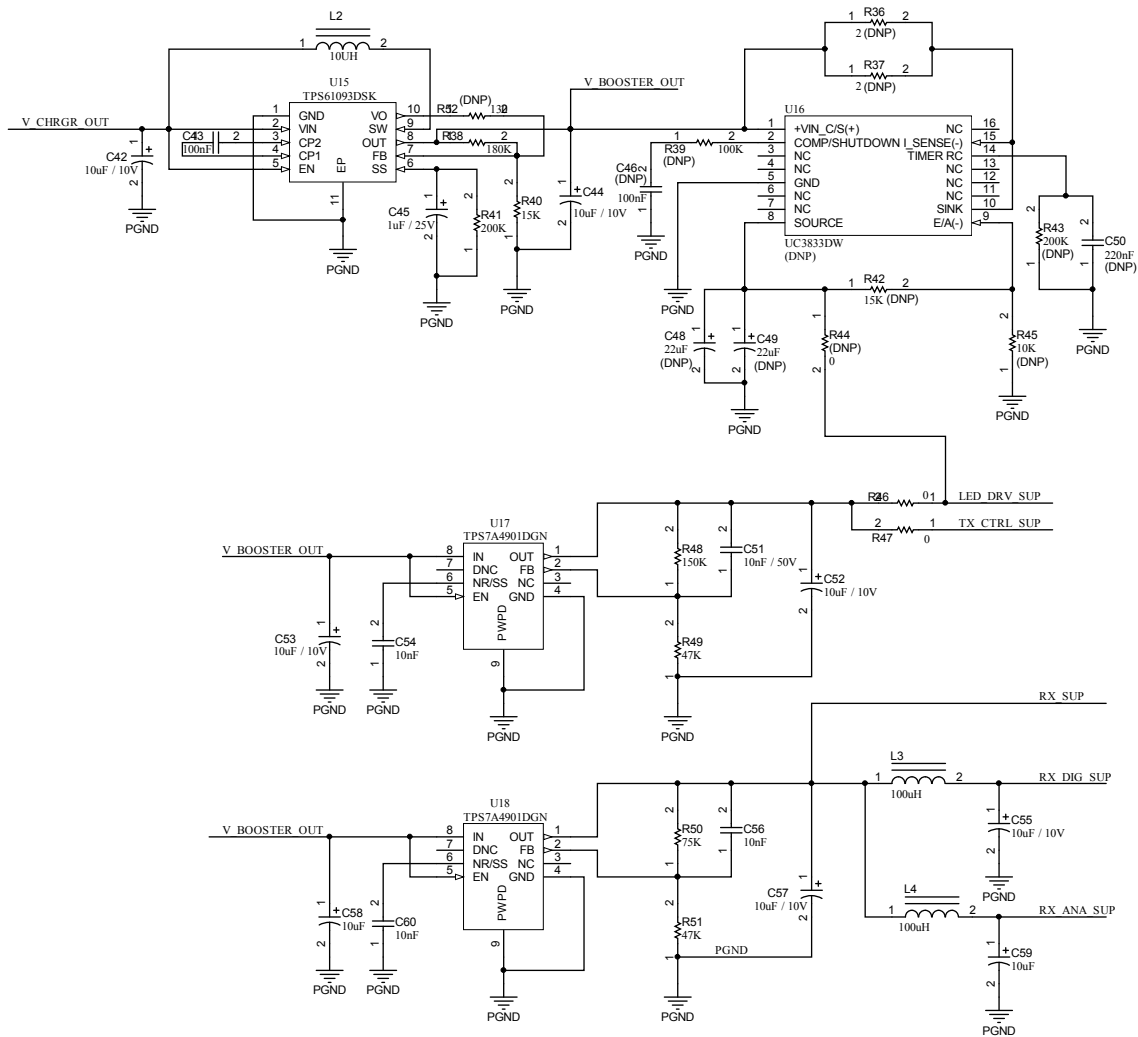

Texas Instruments and/or its licensors do not warrant the accuracy or completeness of this specification or any information contained therein. Texas Instruments and/or its licensors do not warrant that this design will meet the specifications, will be suitable for your application or fit for any particular purpose, or will operate in an implementation. Texas Instruments and/or its licensors do not warrant that the design is production worthy. You should completely validate and test your design implementation to confirm the system functionality for your application.

Designed for: Public Release		Mod. Date: 1/25/2013	
Project: Wrist Watch			
Sheet Title: ChangeMe		Sheet 5 of 5	
Size: A3	Schematic: 870Wrist Watch	Rev. Rev B	
Assembly Variant: Variant name not interpreted			
File: Wrist Watch_Sheet5.SchDoc			
Contact: <a href="http://www.ti.com/support">http://www.ti.com/support</a>			

