



Application Report Power Supply Difference for two (Vcc/ Vdd) Power Supply Products

1. Introduction

This application Report describes specification for power supply voltage difference of TI's audio converter product which has digital Vdd (+3.3V) power supply and analog Vcc (+5V) power supply. Data sheet of those products does not shows this specification clearly or it is difficult under stand this specifications from data sheet.

2. Internal Equivalent Circuit for Vcc/Vdd

Internal equivalent circuit including protection circuit is shown in Figure-1 and Figure-2.

Circuit type-1 by Figure-1 is used for mainly PCM160X family and PCM174X family.

In case of this type-1 product, current pass may occur when voltage difference between Vcc(+5V) and Vdd (+3.3V) excess 3.0V by turn-on diode forward voltage.

Current value from Vcc to Vdd is given by source impedance of Vdd at Vdd=OFF or transient to ON/OFF switching.

Therefore, voltage difference between Vcc(+5V) and Vdd(+3.3V) must be less than 0.3V including power on/off transient time by type-1 products.

In case of Type-2, there is not any pass root between Vcc and Vdd even dough volatage difference excess 3.0V.

Therefore, type-2 products accept over than 3.0V voltage difference including power in/off transient time.

But, each specified maximum power supply voltage by product must be achieved.

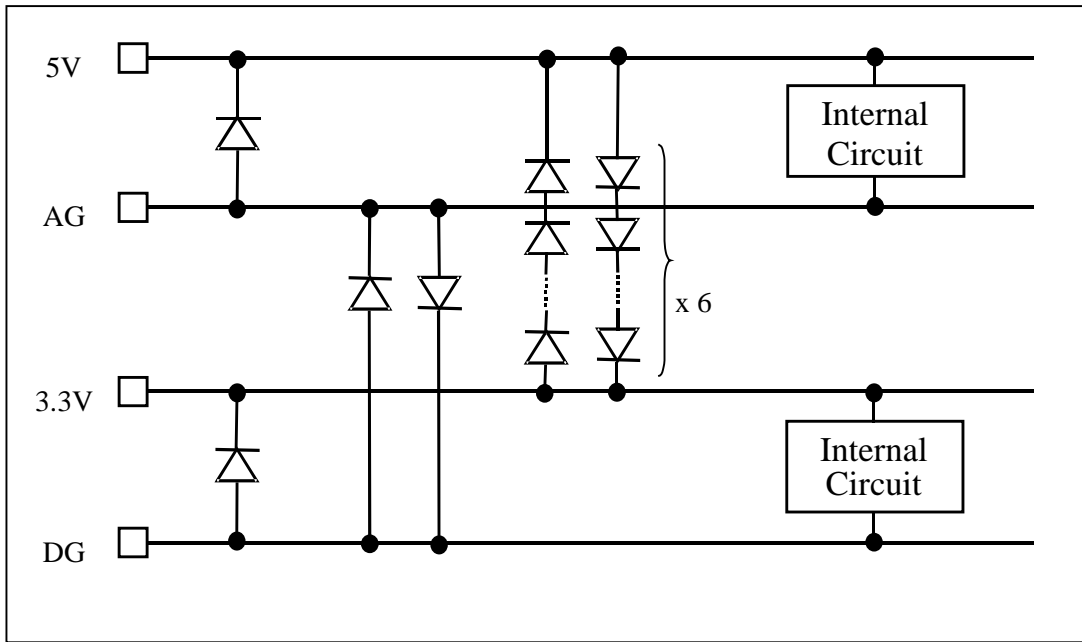

Figure-1 Vcc/Vdd Internal equivalent circuit-1

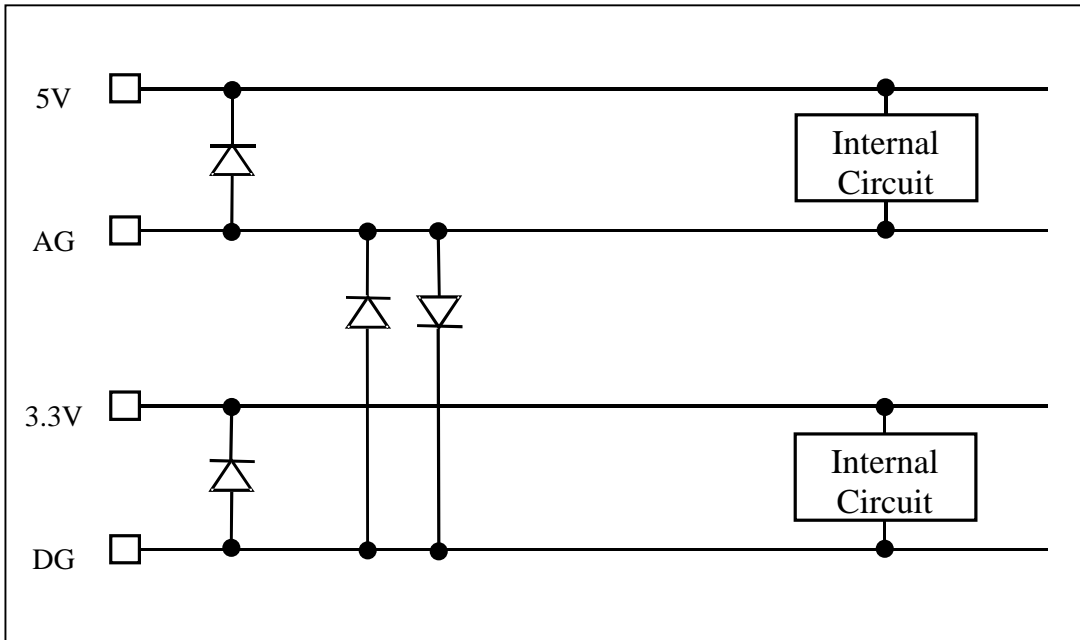

Figure-2 Vcc/Vdd Internal equivalent circuit-2

3. Specification for voltage difference

Due to internal equivalent circuit which is shown in section 2, specification for voltage difference can be clearly specified as shown in below.

3-1. Specification-1 : Voltage difference.....3.0V

3-2. Specification-2 : Voltage difference.....does not care

Maximum power supply for each Vcc and Vdd on absolute maximum ratings must be applied

Applied product model by specification-1 and specification-2 is shown in table-1.

4. Consideration for applications

4-1. Specification-1 Products

As guaranteed specification, voltage difference between Vcc and Vdd including power supply ON/OFF transient must be less than 3.0V.

In actual application, in short time, over than 3.0V voltage difference is estimated due to difference transient time by each power supply circuit.

Device may not broken by that transient over voltage difference. It is acceptable as actual performance.

But, it strongly recommended to provide specified voltage difference including power on/off transient.

4-2. Specification-2 Products

This product accepts any voltage difference within each maximum power supply voltage.

For example, Vcc=5.0V, Vdd=0V or Vcc=0V, Vdd=3.3V power supply.

5. Specification by product model

Table-1 Specification by products

Specification-1 products	Specification-2 products
DSD1702	PCM1791A
PCM1600	DSD1608
PCM1601	DSD1791
PCM1602	PCM1792
PCM1603	DSD1792
PCM1604	PCM1793
PCM1605	DSD1793
PCM1608	PCM1794
PCM1737	DSD1794
PCM1738	PCM2704
PCM1742	PCM2705
PCM1743	PCM2706/2707
PCM1748	PCM3010
PCM1802	PCM1807/08
PCM1804	
PCM2702	
PCM2900/2901/2902/2903/2904/2906	
PCM1609	

- * Please ask to us non listed model
- * Same power supply products (e.g. DIR1703 is operated by $V_{cc}=V_{dd}=3.3V$) does not applied this application report.