

EXPANSION I/O REVD BOARD

TABLE OF CONTENTS

SL NO.	CONTENTS	PAGE NO
1	TABLE OF CONTENTS	1
2	VERSION HISTORY	2
3	BLOCK DIAGRAM	3
4	MEMORY MAP	4
5	D-VIDEO APPLICATION CONN	5
6	GPMC APPLICATION CONN	6
7	M-CARD APPLICATION CONN	7
8	S/PDIF	8
9	RESERVE2	9
10	VIDEO & GRAPHICS DIGITIZER	10
11	TVP7002 RGB	11
12	TVP7002 POWER	12
13	DVI INTERFACE	13
14	DVI INPUT - Sii1161	14
15	DVI POWER	15
16	IO EXPANDER	16
17	UART	17
18	CAMERA BUFFER	18
19	PARALLEL CAMERA CONN	19
20	TVP5147 INPUT	20
21	TVP5147 POWER	21
22	VINO MUXING	22
23	RESERVE0	23
24	RESERVE1	24

SL NO.	CONTENTS	PAGE NO
25	ACCELEROMETER	25
26	BOARD ID EEPROM	26
27	LCD & TOUCH SCREEN	27
28	NOR FLASH	28
29	DCAN INTERFACE	29
30	COM7 CONNECTOR - WLAN & BT	30
31	WLAN MODULE BUFFERS	31
32	POWER SUPPLY	32

REV	D
VERSION	0.06

REV NO.	NATURE OF CHANGE	APPROVED BY	DATE	 Mistral Solutions [P] Ltd. #60 Adarsh regent,100 Feet Ring Road, Domlur Extension Bangalore 560 071, Ph : +91-80-30912600, Fax :+91-80-2535 6444		Title	TABLE OF CONTENTS	
				Drawn by: Mistral Design Team Date: Monday, May 31, 2010	Approved by: Mistral Approval Team Date: Saturday, November 12, 2011	Size: B Document Number: MS_TI_DM814x_EXP_IO_REVD_SCH	Rev: D	Date: Friday, October 28, 2011 Sheet 1 of 32

VERSION HISTORY

VER #	DATE	DESCRIPTION OF CHANGES	AUTHOR	REVIEWED BY	APPROVED BY
0.01	21/9/2011	As per change list ver 0.01 on MS_TI_CEN_EXP_IO_REVD_CHNG_LIST.xls	Mistral Design Team	Mistral Review Team	Mistral Approval Team
0.02	7/10/2011	As per change list ver 0.02 on MS_TI_CEN_EXP_IO_REVD_CHNG_LIST.xls	Mistral Design Team	Mistral Review Team	Mistral Approval Team
0.03	11/10/2011	As per change list ver 0.03 on MS_TI_CEN_EXP_IO_REVD_CHNG_LIST.xls	Mistral Design Team	Mistral Review Team	Mistral Approval Team
0.04	21/10/2011	As per change list ver 0.04 on MS_TI_CEN_EXP_IO_REVD_CHNG_LIST.xls	Mistral Design Team	Mistral Review Team	Mistral Approval Team
0.05	24/10/2011	As per change list ver 0.05 on MS_TI_CEN_EXP_IO_REVD_CHNG_LIST.xls	Mistral Design Team	Mistral Review Team	Mistral Approval Team
0.06	28/10/2011	Net name changed as per DM814x Reserved Signal Name Cross Reference chart.xls doc	Mistral Design Team	Mistral Review Team	Mistral Approval Team

REV NO.	NATURE OF CHANGE	APPROVED BY	DATE	 Mistral Solutions [P] Ltd. #60 Adarsh regent, 100 Feet Ring Road, Domlur Extension Bangalore 560 071, Ph : +91-80-30912600, Fax : +91-80-2535 6444	Title	VERSION HISTORY	
					Drawn by: Mistral Design Team Date: Monday, May 31, 2010	Approved by: Mistral Approval Team Date: Saturday, November 12, 2011	Size: B Document Number: MS_TI_DM814x_EXP_IO_REVD_SCH
				Design file path:	Date: Friday, October 28, 2011	Sheet 2 of 32	

BLOCK DIAGRAM: EXPANSION I/O BOARD-REV D

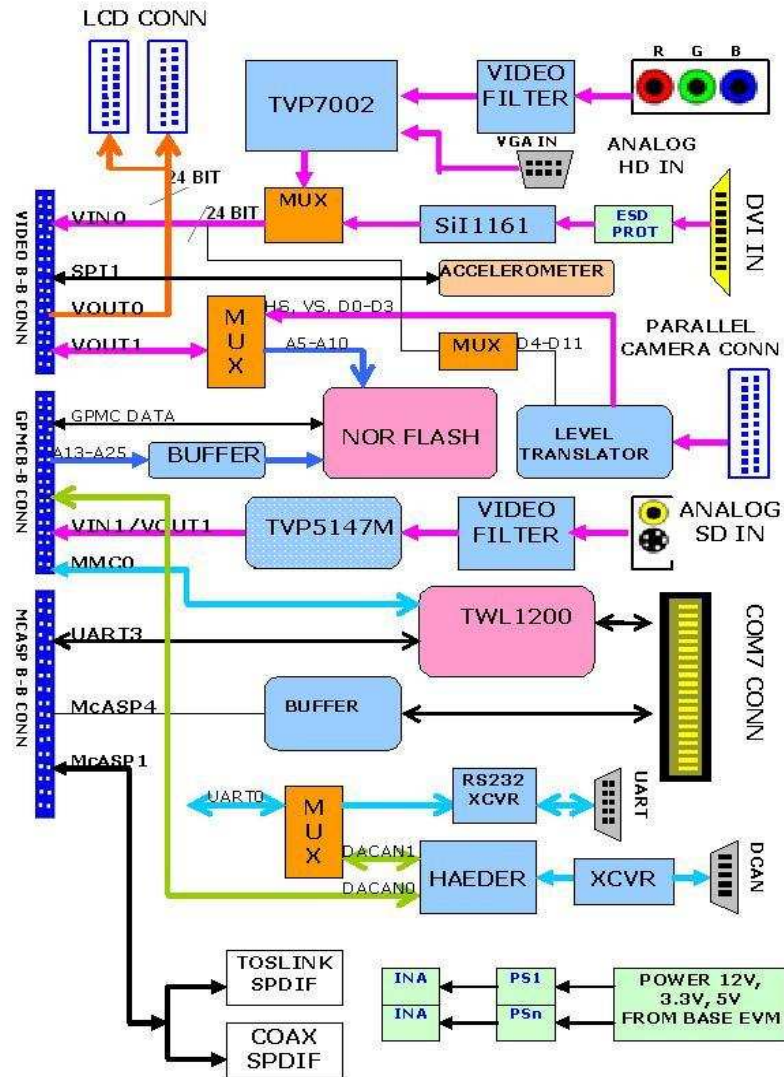

REV NO.	NATURE OF CHANGE	APPROVED BY	DATE	Mistral Solutions [P] Ltd. MISTRAL #60 Adarsh regent, 100 Feet Ring Road, Domlur Extension Bangalore 560 071, Ph : +91-80-30912600, Fax :+91-80-2535 6444		Title	BLOCK DIAGRAM	
				Drawn by: Mistral Design Team	Approved by: Mistral Approval Team	Size	Document Number	Rev
				Date: Monday, May 31, 2010	Date: Saturday, November 12, 2011	B	MS_TI_DM814x_EXP_IO_REV D_SCH	D
				Design file path:		Date: Saturday, November 12, 2011	Sheet 3 of 32	

MEMORY MAP

INTERRUPT

INTERRUPT NAME	GPIO
TVP5147_INTREQ	GP1[30]
IOEXP1_INT#	GP1[9]
IOEXP2_INT#	GP1[27]

I2C

I2C DEVICE	I2C	I2C ADDR
BOARD ID	I2C0	0X51
PCF8575	I2C0	0X21
LCD TOUCH SCREEN	I2C0	Default
TVP7002	I2C2	0X5D
SiI1161	I2C2	0X3B
PCF8575	I2C2	0X21
TVP5147	I2C2	0X5C
CAMERA	I2C2	
LCD TOUCH SCREEN	I2C2	

Default

REV NO.	NATURE OF CHANGE	APPROVED BY	DATE	Mistral Solutions [P] Ltd. #60 Adarsh regent,100 Feet Ring Road, Domlur Extension Bangalore 560 071, Ph : +91-80-30912600, Fax :+91-80-2535 6444	Title	Size	Document Number	Rev
					MEMORY MAP	B	MS_TI_DM814x_EXP_IO_REVD_SCH	D
				Drawn by: Mistral Design Team Date: Monday, May 31, 2010	Approved by: Mistral Approval Team Date: Saturday, November 12, 2011			
				Design file path:	Date: Friday, October 28, 2011		Sheet 4 of 32	

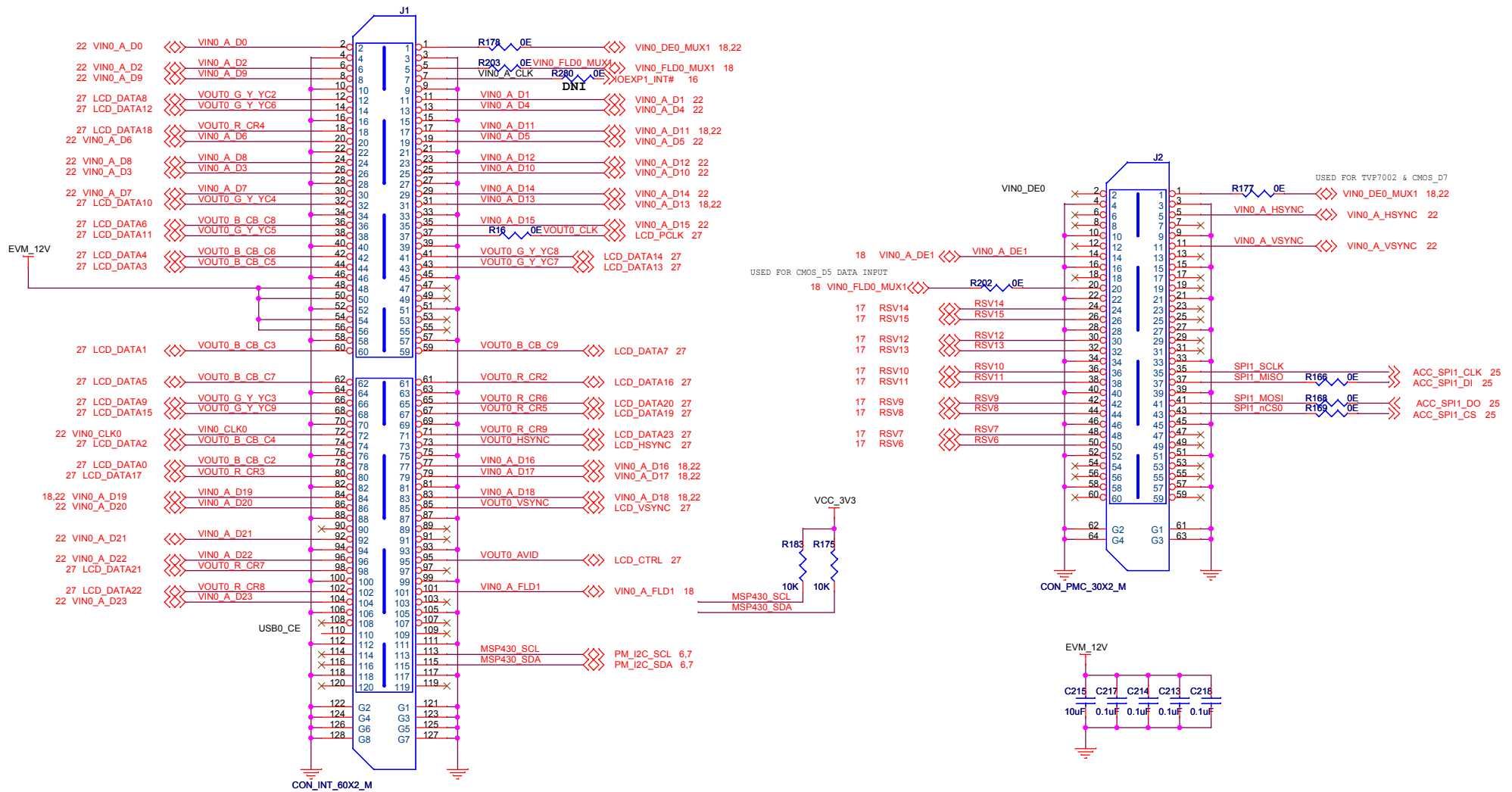

REV NO.	NATURE OF CHANGE	APPROVED BY	DATE	Mistral Solutions [P] Ltd. #60 Adarsh regent, 100 Feet Ring Road, Domlur Extension Bangalore 560 071, Ph : +91-80-30912600, Fax :+91-80-2535 6444		Title	D-VIDEO APPLICATION CONN		
				Drawn by: Mistral Design Team	Approved by: Mistral Approval Team	Size	Document Number		Rev
				Date: Monday, May 31, 2010	Date: Saturday, November 12, 2011	B	MS_TI_DM814x_EXP_IO_REVD_SCH		D
				Design file path:		Date:	Friday, October 28, 2011	Sheet	5 of 32

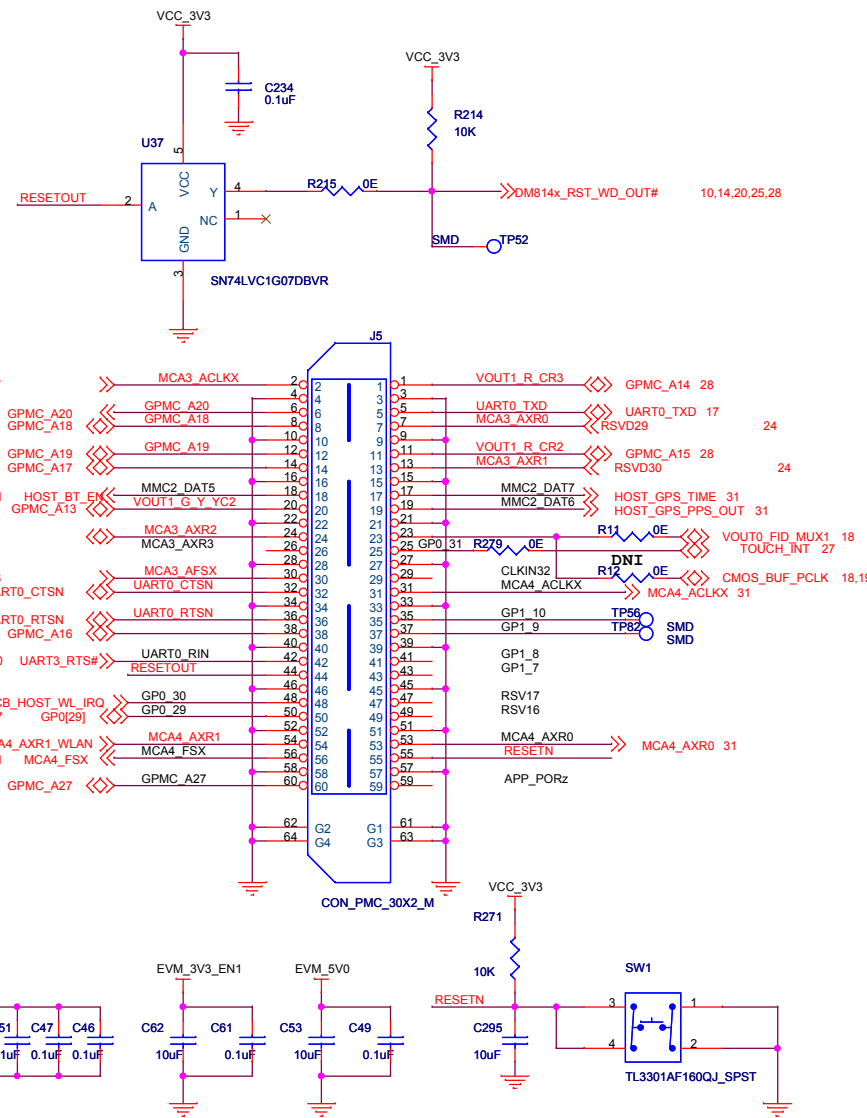
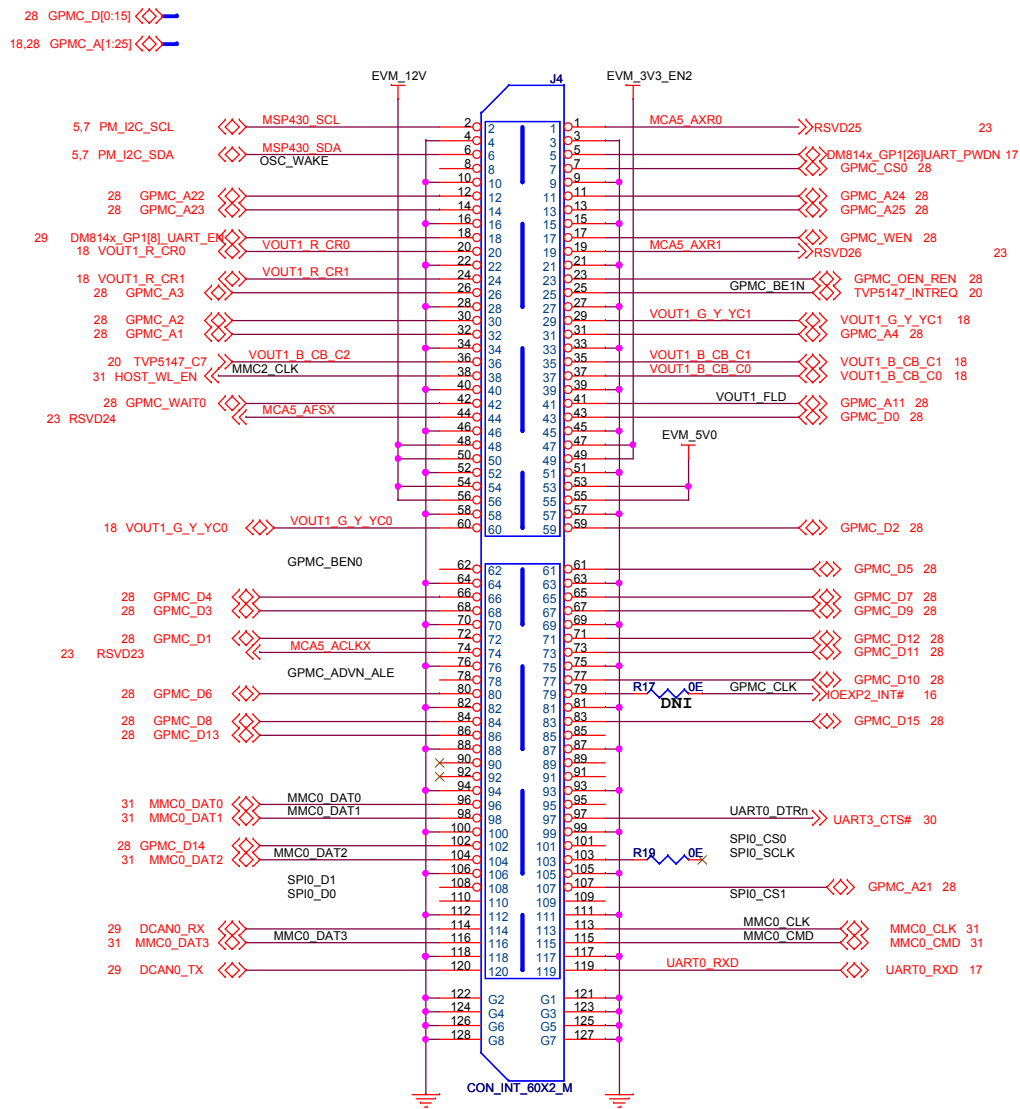

REV NO.	NATURE OF CHANGE	APPROVED BY	DATE	Mistral Solutions [P] Ltd.		Title	
				Mistral Solutions [P] Ltd. #60 Adarsh regent, 100 Feet Ring Road, Domlur Extension Bangalore 560 071, Ph : +91-80-30912600, Fax : +91-80-2535 6444		GPMC APPLICATION CONN	
				Drawn by: Mistral Design Team Date: Monday, May 31, 2010	Approved by: Mistral Approval Team Date: Saturday, November 12, 2011	Size: B Document Number: MS_TI_DM814x_EXP_IO_REVD_SCH	Rev: D
				Design file path:		Date: Friday, October 28, 2011	Sheet 6 of 32

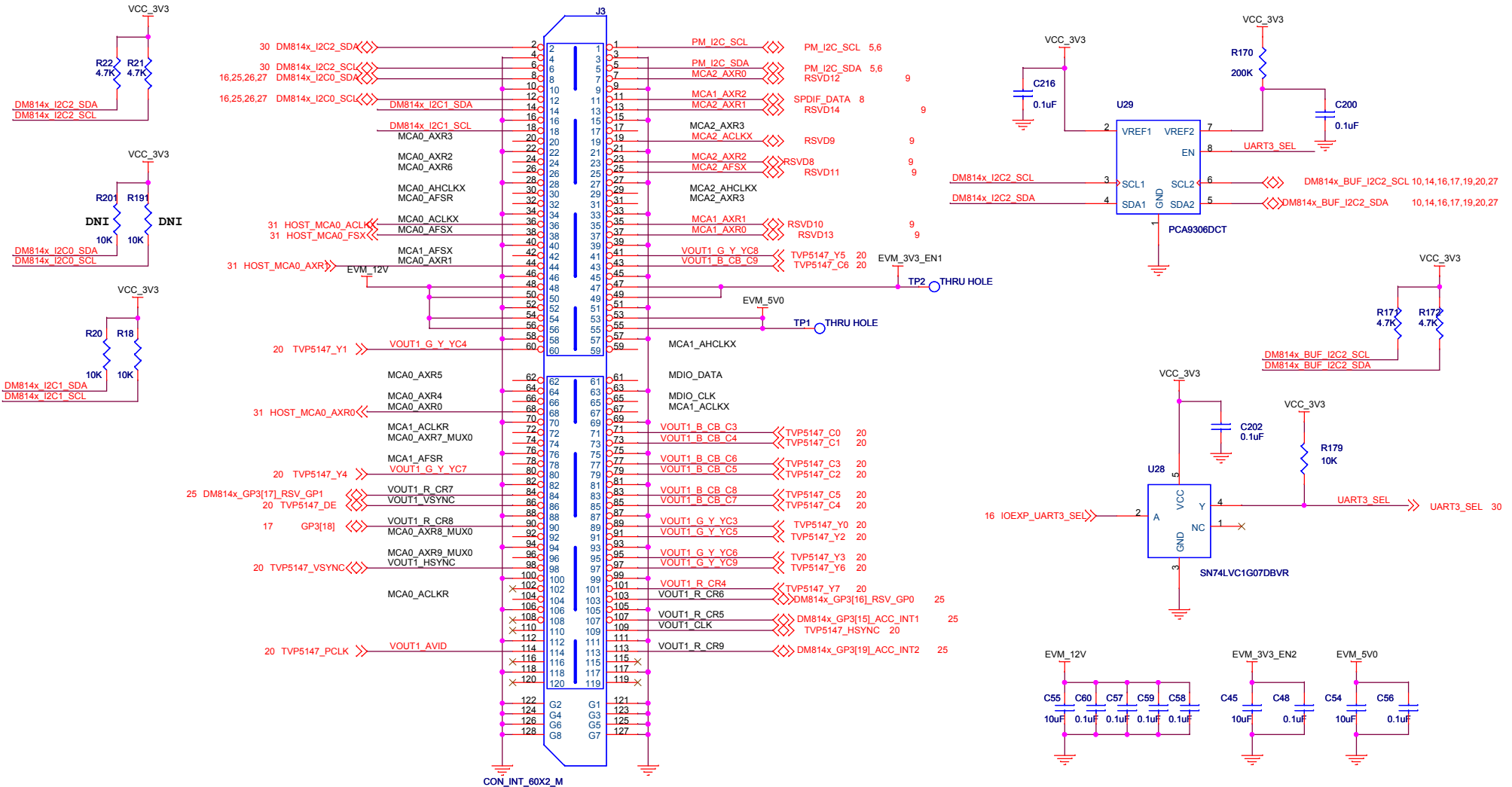

REV NO.	NATURE OF CHANGE	APPROVED BY	DATE	Mistral Solutions [P] Ltd.		Title	
				Mistral Solutions [P] Ltd. #60 Adarsh regent, 100 Feet Ring Road, Domlur Extension Bangalore 560 071, Ph : +91-80-30912600, Fax : +91-80-2535 6444		M-CARD APPLICATION CONN	
				Drawn by: Mistral Design Team Date: Monday, May 31, 2010	Approved by: Mistral Approval Team Date: Saturday, November 12, 2011	Size: B Document Number: MS_TI_DM814x_EXP_IO_REVD_SCH	Rev: D
				Design file path:		Date: Friday, October 28, 2011	Sheet 7 of 32

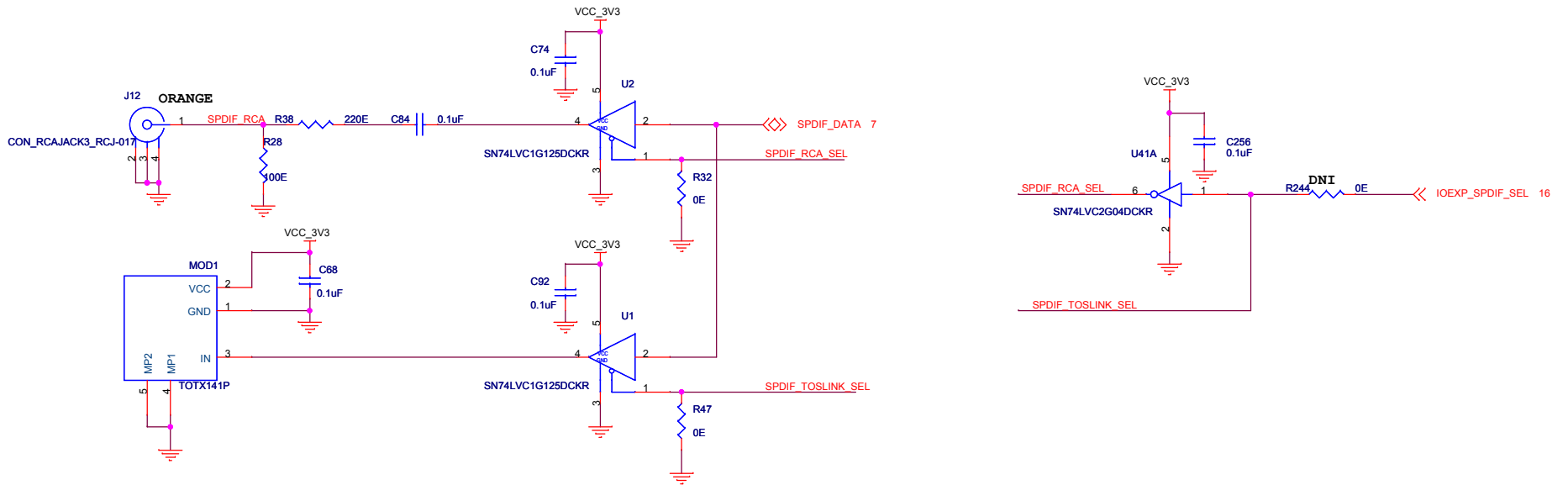

REV NO.	NATURE OF CHANGE	APPROVED BY	DATE



Mistral Solutions [P] Ltd.
 #60 Adarsh regent, 100 Feet Ring Road, Domlur Extension
 Bangalore 560 071, Ph : +91-80-30912600, Fax : +91-80-2535 6444

Drawn by: Mistral Design Team
 Date: Monday, May 31, 2010

Approved by: Mistral Approval Team
 Date: Saturday, November 12, 2011

Design file path:

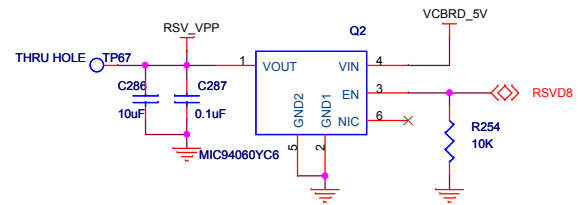
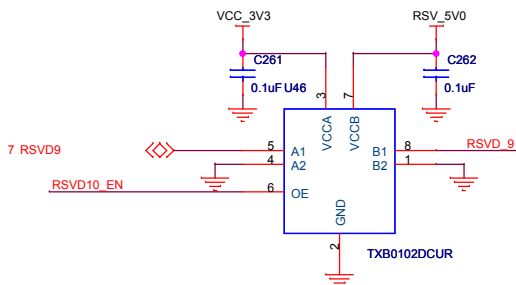
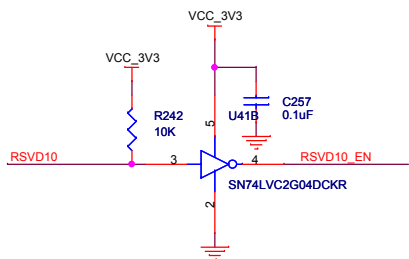
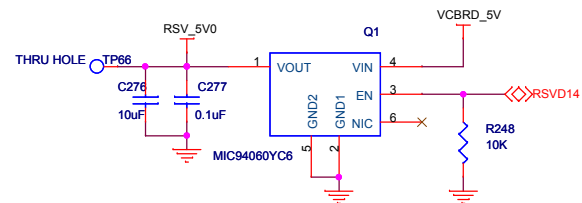
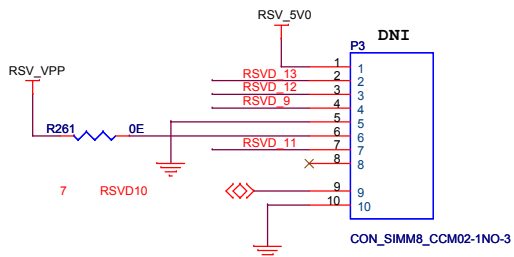
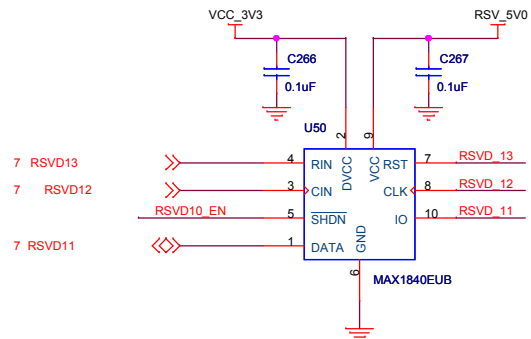
Title		S/PDIF	
Size	Document Number	Rev	
B	MS_TI_DM814x_EXP_IO_REVD_SCH	D	
Date:	Friday, October 28, 2011	Sheet	8 of 32



REV NO.	NATURE OF CHANGE	APPROVED BY	DATE	Mistral Solutions [P] Ltd. #60 Adarsh regent, 100 Feet Ring Road, Domlur Extension Bangalore 560 071, Ph : +91-80-30912600, Fax : +91-80-2535 6444		Title	RESERVE2	
				Drawn by: Mistral Design Team	Approved by: Mistral Approval Team	Size	Document Number	Rev
				Date: Monday, May 31, 2010	Date: Saturday, November 12, 2011	B	MS_TI_DM814x_EXP_IO_REVD_SCH	D
				Design file path:		Date: Friday, October 28, 2011	Sheet 9 of 32	

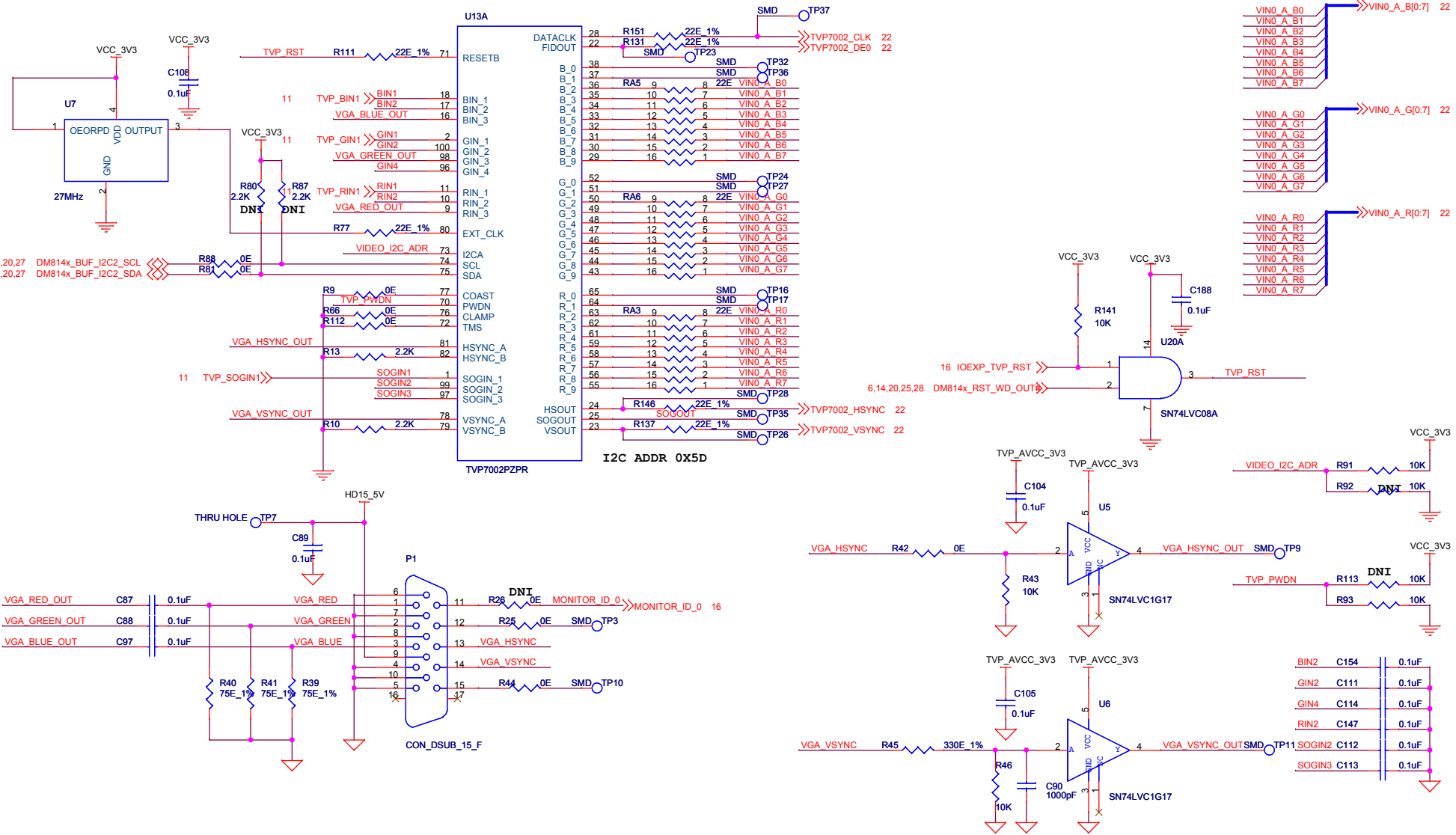

REV NO.	NATURE OF CHANGE	APPROVED BY	DATE



Mistral Solutions [P] Ltd.
 #60 Adarsh regent, 100 Feet Ring Road, Domlur Extension
 Bangalore 560 071, Ph : +91-80-30912600, Fax : +91-80-2535 6444

Drawn by: Mistral Design Team
 Date: Monday, May 31, 2010

Approved by: Mistral Approval Team
 Date: Saturday, November 12, 2011

Design file path:

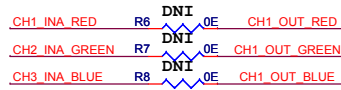
Title		Size	Document Number	Rev
VIDEO & GRAPHICS DIGITIZER		B	MS_TI_DM814x_EXP_IO_REVD_SCH	D
Date:	Friday, October 28, 2011	Sheet	10	of 32



Note: R6, R7, R8 should be placed under U9

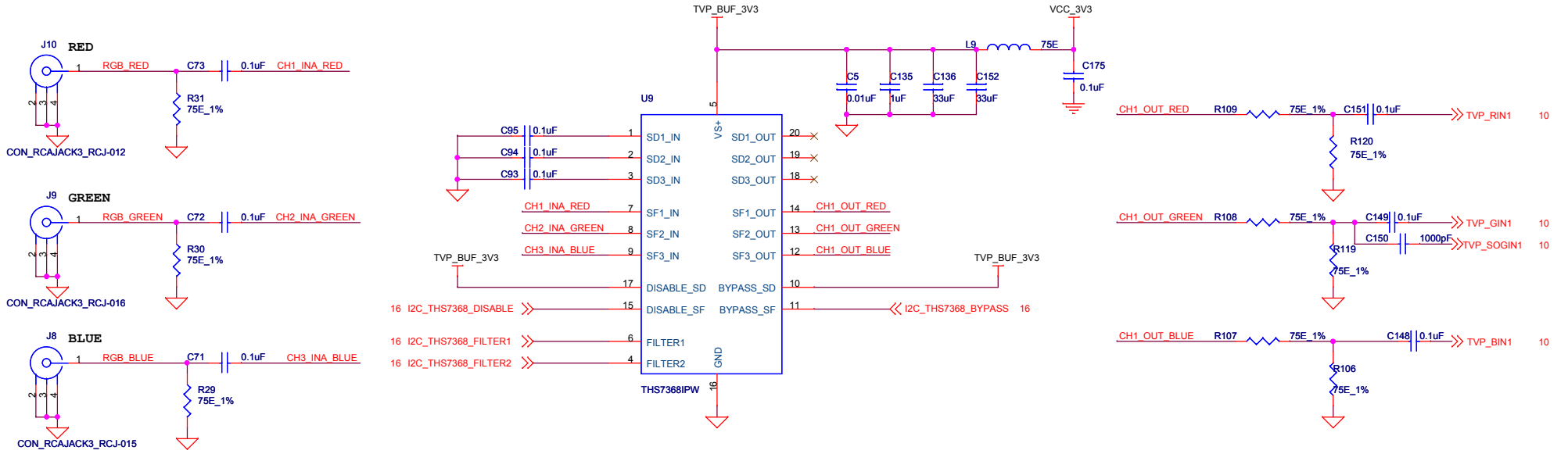
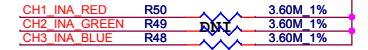

REV NO.	NATURE OF CHANGE	APPROVED BY	DATE	Mistral Solutions [P] Ltd. MISTRAL #60 Adarsh regent, 100 Feet Ring Road, Domlur Extension Bangalore 560 071, Ph : +91-80-30912600, Fax : +91-80-2535 6444		Title	TVP7002 RGB	
				Drawn by: Mistral Design Team	Approved by: Mistral Approval Team	Size	Document Number	Rev
				Date: Monday, May 31, 2010	Date: Saturday, November 12, 2011	B	MS_TI_DM814x_EXP_IO_REVD_SCH	D
				Design file path:		Date: Friday, October 28, 2011	Sheet 11 of 32	

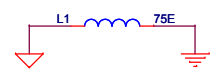
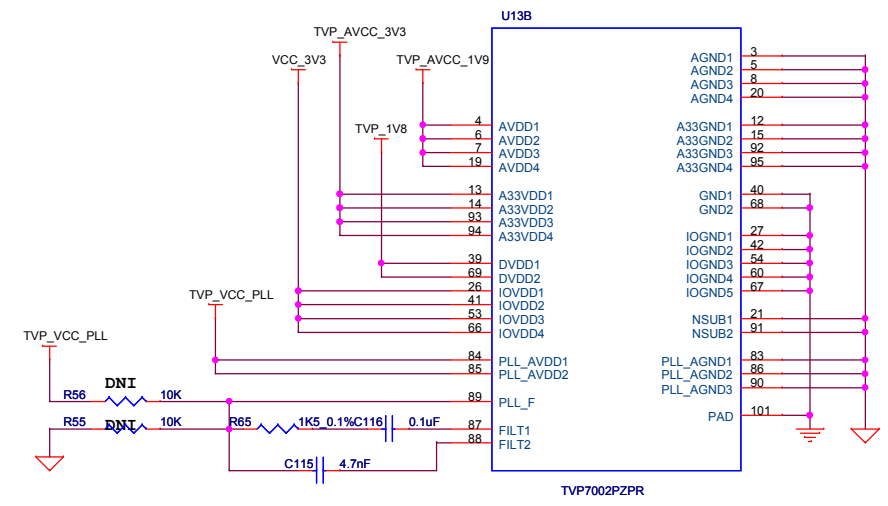
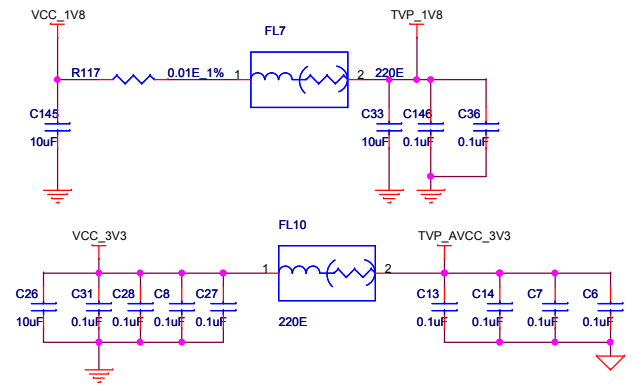
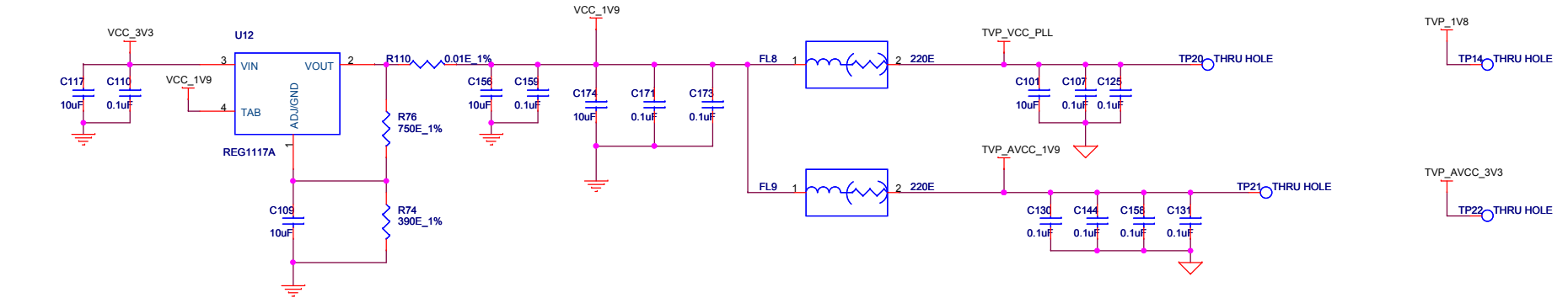

REV NO.	NATURE OF CHANGE	APPROVED BY	DATE	Mistral Solutions [P] Ltd.		Title	
				Mistral Solutions [P] Ltd. #60 Adarsh regent, 100 Feet Ring Road, Domlur Extension Bangalore 560 071, Ph : +91-80-30912600, Fax : +91-80-2535 6444		TVP7002 POWER	
				Drawn by: Mistral Design Team Date: Monday, May 31, 2010	Approved by: Mistral Approval Team Date: Saturday, November 12, 2011	Size: B Document Number: MS_TI_DM814x_EXP_IO_REVD_SCH	Rev: D
				Design file path:		Date: Friday, October 28, 2011	Sheet 12 of 32

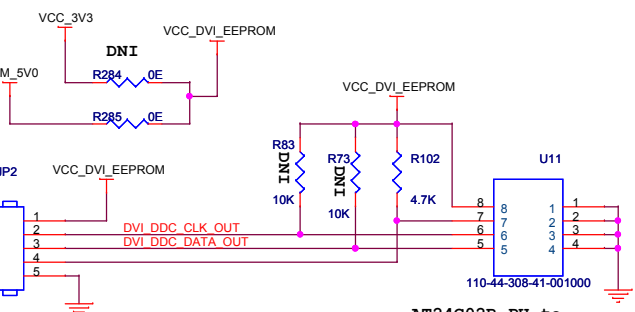
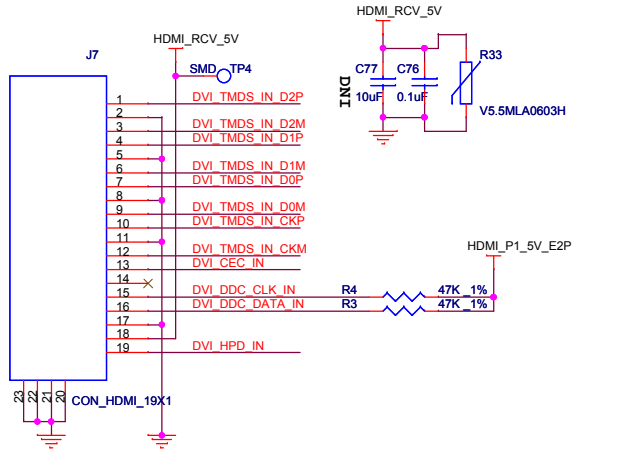

HDR_5X1
Place the Header such that LCD Adapter Board should not cover the Header

AT24C02B-PU to be included in Accessory

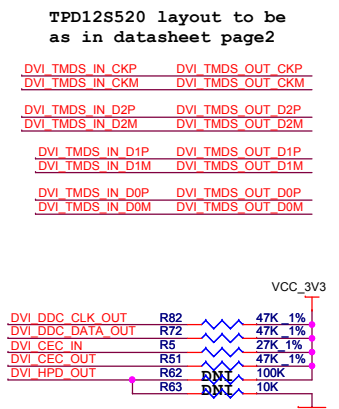
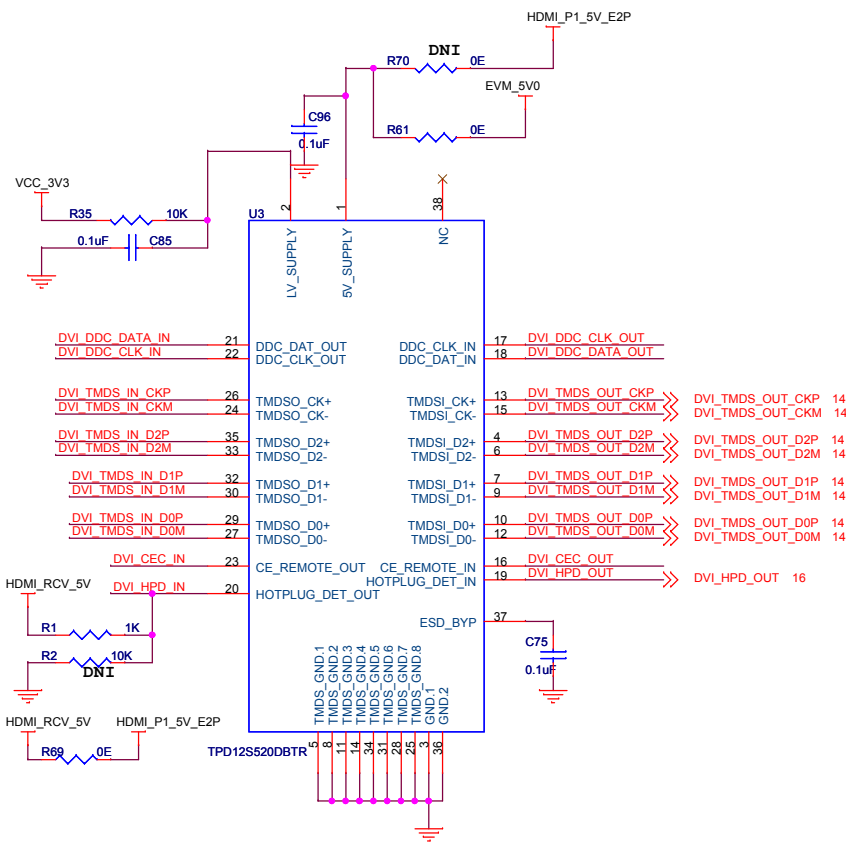

REV NO.	NATURE OF CHANGE	APPROVED BY	DATE

Mistral Solutions [P] Ltd.
 #60 Adarsh regent, 100 Feet Ring Road, Domlur Extension
 Bangalore 560 071, Ph : +91-80-30912600, Fax : +91-80-2535 6444

Drawn by: Mistral Design Team
 Date: Monday, May 31, 2010

Approved by: Mistral Approval Team
 Date: Saturday, November 12, 2011

Design file path:

Title		Size	Document Number	Rev
DVI INTERFACE		B	MS_TI_DM814x_EXP_IO_REVD_SCH	D
Date:	Friday, October 28, 2011	Sheet	13 of	32

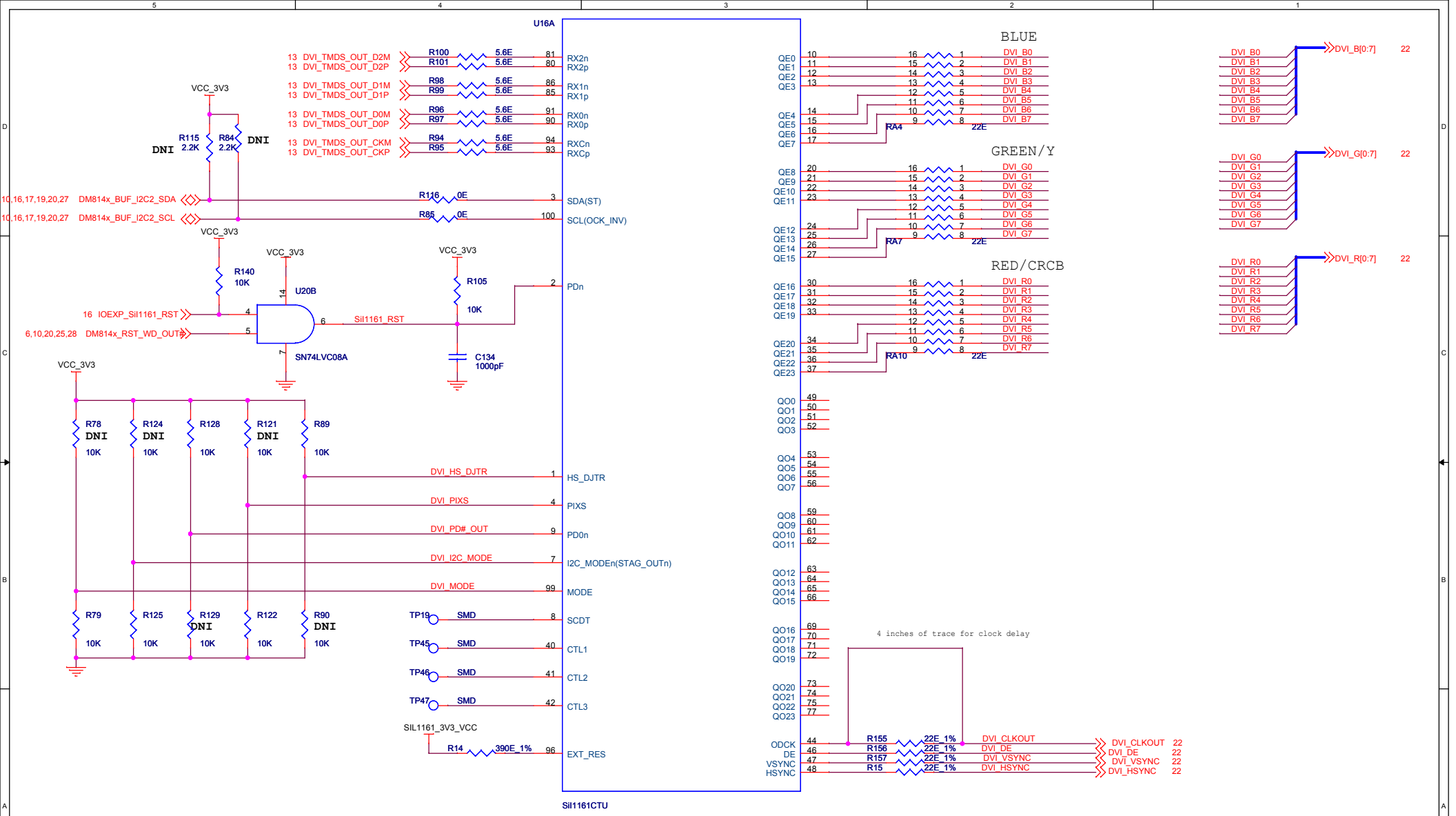

REV NO.	NATURE OF CHANGE	APPROVED BY	DATE	Mistral Solutions [P] Ltd.		Title	
				Mistral Solutions [P] Ltd. #60 Adarsh regent, 100 Feet Ring Road, Domlur Extension Bangalore 560 071, Ph : +91-80-30912600, Fax : +91-80-2535 6444		DVI INPUT - Sii1161	
				Drawn by: Mistral Design Team Date: Monday, May 31, 2010	Approved by: Mistral Approval Team Date: Saturday, November 12, 2011	Size: B Document Number: MS_TI_DM814x_EXP_IO_REVD_SCH	Rev: D
				Design file path:		Date: Friday, October 28, 2011	Sheet 14 of 32

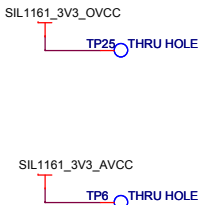
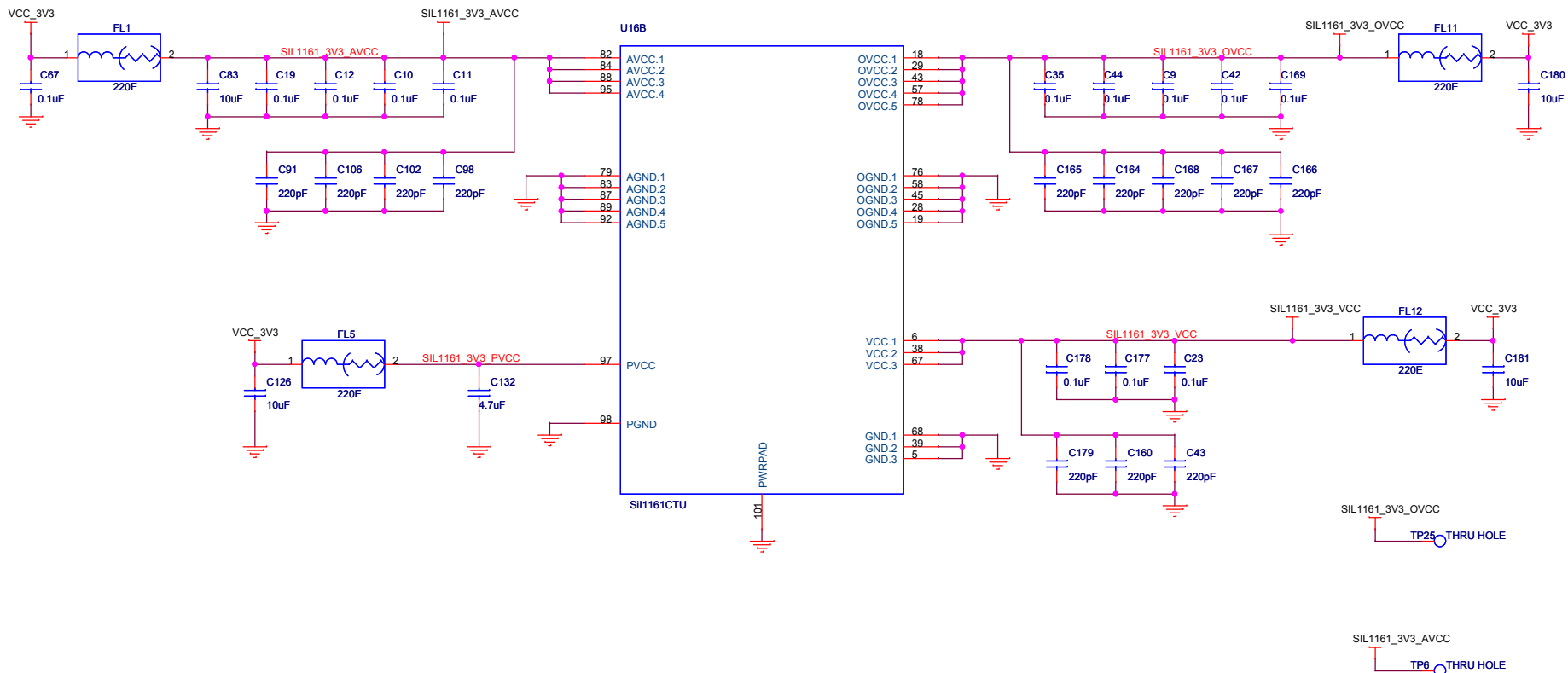

REV NO.	NATURE OF CHANGE	APPROVED BY	DATE



Mistral Solutions [P] Ltd.
 #60 Adarsh regent, 100 Feet Ring Road, Domlur Extension
 Bangalore 560 071, Ph : +91-80-30912600, Fax : +91-80-2535 6444

Drawn by: Mistral Design Team
 Date: Monday, May 31, 2010

Approved by: Mistral Approval Team
 Date: Saturday, November 12, 2011

Design file path:

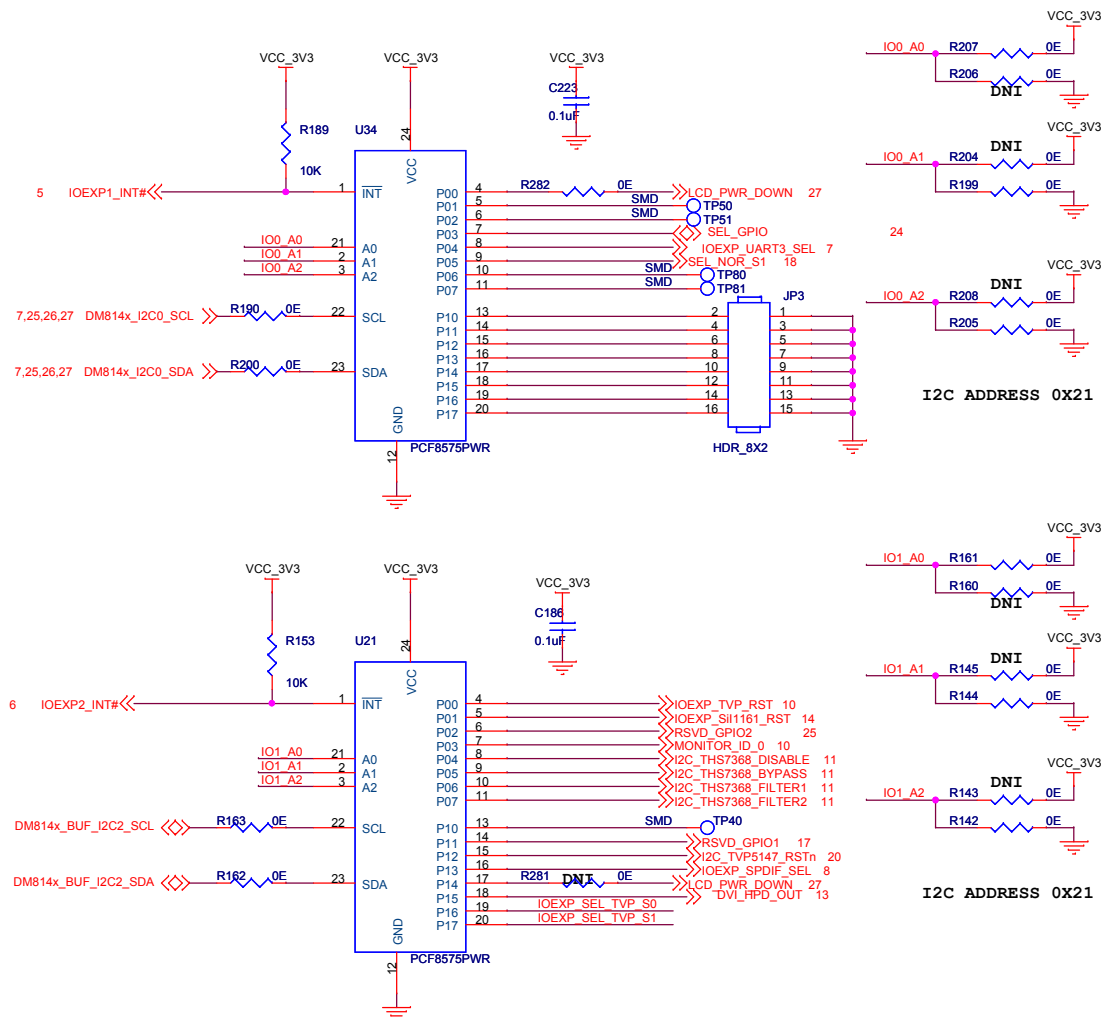
Title		DVI POWER	
Size	Document Number	Rev	
B	MS_TI_DM814x_EXP_IO_REVD_SCH	D	
Date:	Friday, October 28, 2011	Sheet	15 of 32



I2C ADDRESS 0X21

I2C ADDRESS 0X21

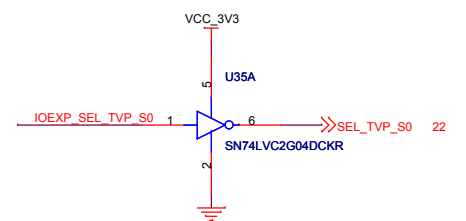
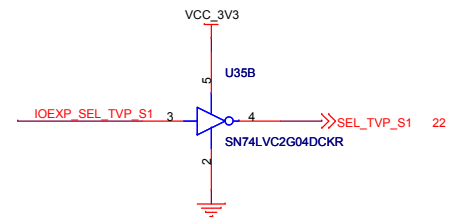

REV NO.	NATURE OF CHANGE	APPROVED BY	DATE	Mistral Solutions [P] Ltd.		Title	
				Mistral Solutions [P] Ltd. #60 Adarsh regent, 100 Feet Ring Road, Domlur Extension Bangalore 560 071, Ph : +91-80-30912600, Fax : +91-80-2535 6444		IO EXPANDER	
				Drawn by: Mistral Design Team Date: Monday, May 31, 2010	Approved by: Mistral Approval Team Date: Saturday, November 12, 2011	Size: B Document Number: MS_TI_DM814x_EXP_IO_REVD_SCH	Rev: D
				Design file path:		Date: Friday, October 28, 2011	Sheet 16 of 32

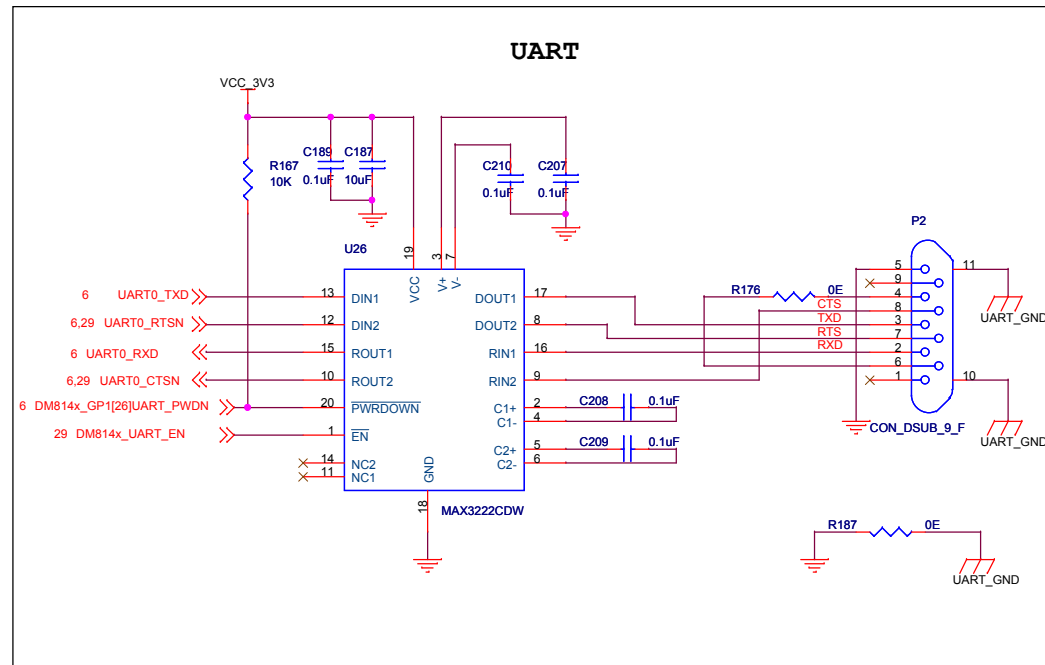
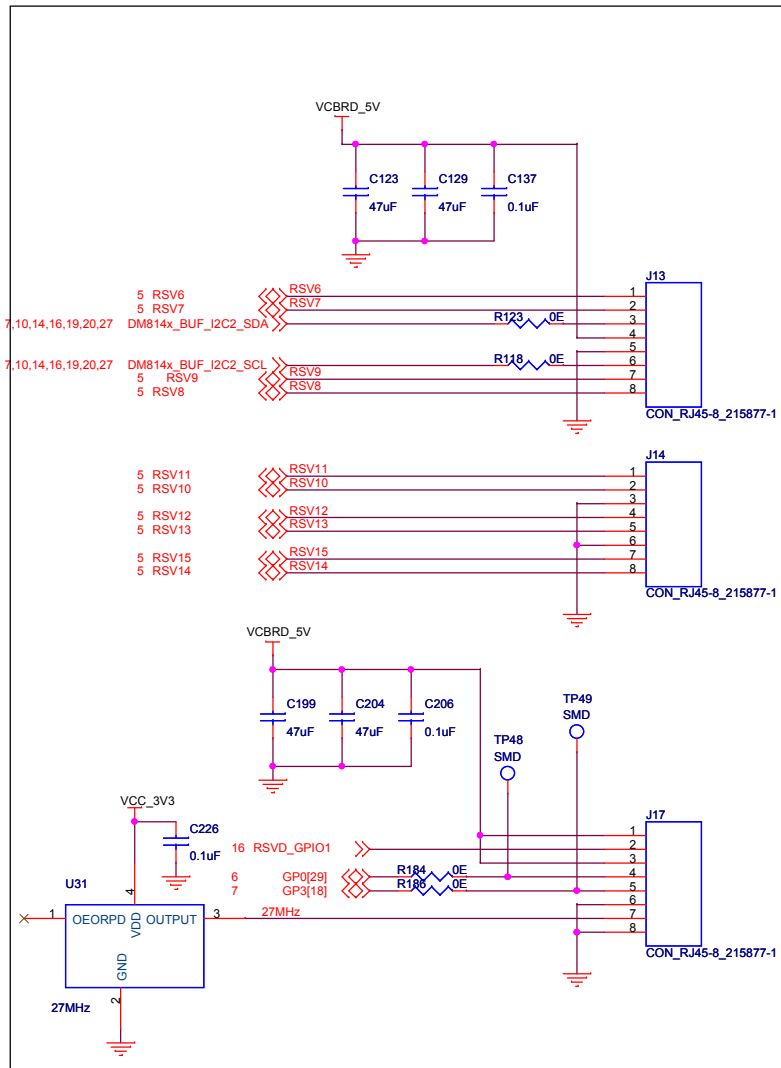

REV NO.	NATURE OF CHANGE	APPROVED BY	DATE	Mistral Solutions [P] Ltd. MISTRAL #60 Adarsh regent,100 Feet Ring Road, Domlur Extension Bangalore 560 071, Ph : +91-80-30912600, Fax :+91-80-2535 6444		Title	UART	
				Drawn by: Mistral Design Team	Approved by: Mistral Approval Team	Size	Document Number	Rev
				Date: Monday, May 31, 2010	Date: Saturday, November 12, 2011	B	MS_TI_DM814x_EXP_IO_REVD_SCH	D
				Design file path:		Date: Friday, October 28, 2011	Sheet 17 of 32	

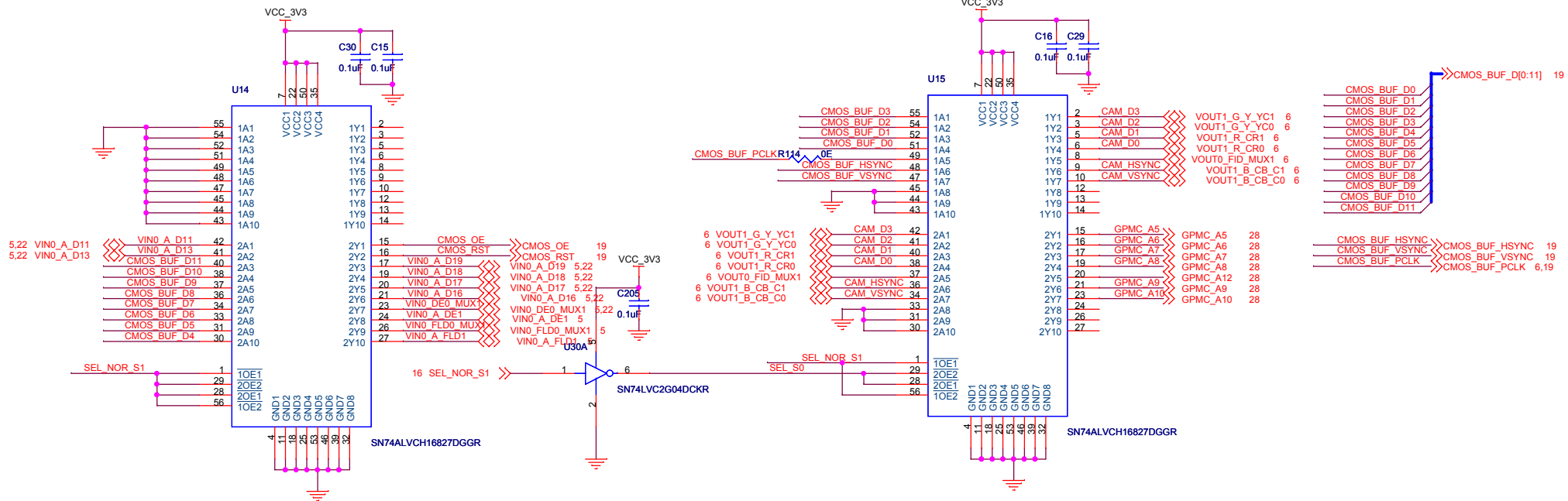

Camera is muxed with VIN0 (TVP7002 & siI1161).
So any one will be selected among these

SEL_NOR_S1	LOW	CAMERA SELECTED
SEL_NOR_S1	HIGH	NOR SELECTED (DEFAULT)

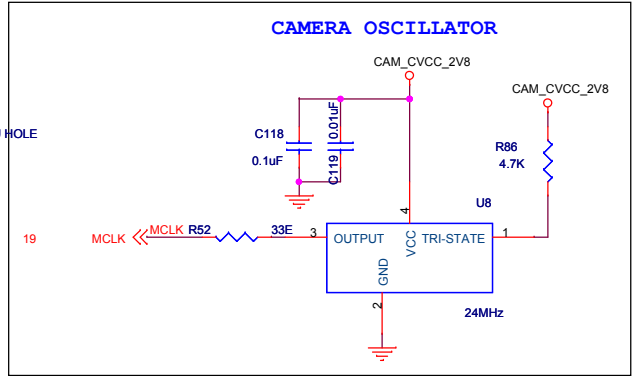
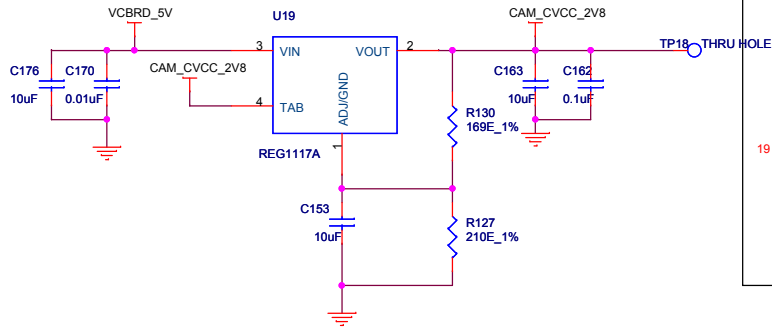

REV NO.	NATURE OF CHANGE	APPROVED BY	DATE	Mistral Solutions [P] Ltd. #60 Adarsh regent, 100 Feet Ring Road, Domlur Extension Bangalore 560 071, Ph : +91-80-30912600, Fax : +91-80-2535 6444	Title	CAMERA BUFFER	
					Drawn by: Mistral Design Team Date: Monday, May 31, 2010	Approved by: Mistral Approval Team Date: Saturday, November 12, 2011	Size: B Document Number: MS_TI_DM814x_EXP_IO_REVD_SCH
Design file path:					Date: Friday, October 28, 2011	Sheet 18 of 32	

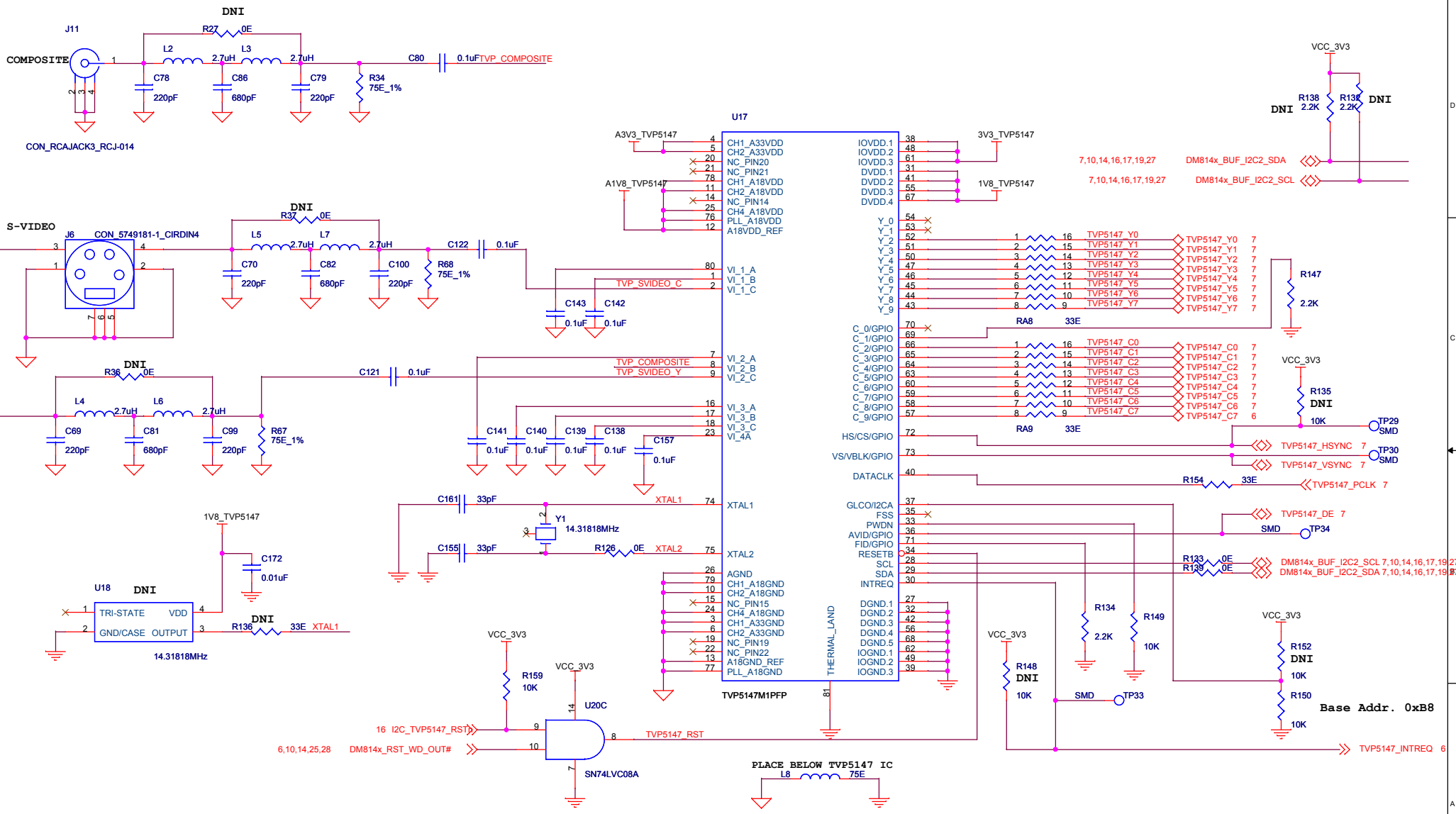

REV NO.	NATURE OF CHANGE	APPROVED BY	DATE	Mistral Solutions [P] Ltd.		Title	
				Mistral Solutions [P] Ltd. #60 Adarsh regent, 100 Feet Ring Road, Domlur Extension Bangalore 560 071, Ph : +91-80-30912600, Fax : +91-80-2535 6444		TVP5147 INPUT	
				Drawn by: Mistral Design Team Date: Monday, May 31, 2010	Approved by: Mistral Approval Team Date: Saturday, November 12, 2011	Size: B Document Number: MS_TI_DM814x_EXP_IO_REVD_SCH	Rev: D
				Design file path:		Date: Friday, October 28, 2011	Sheet 20 of 32

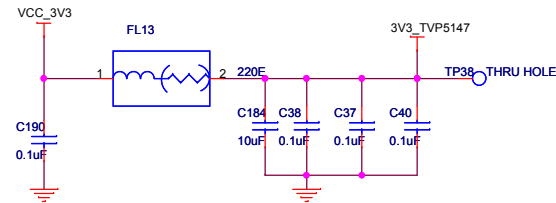
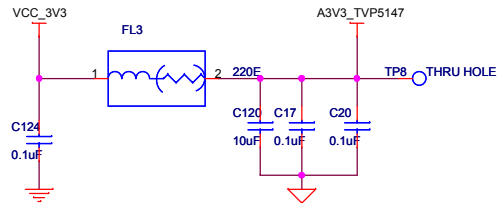
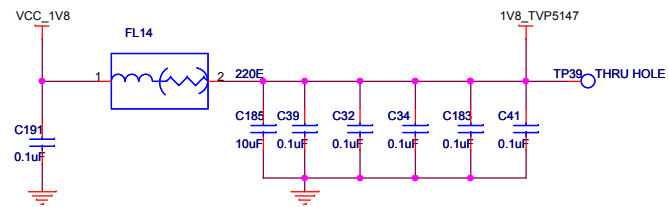
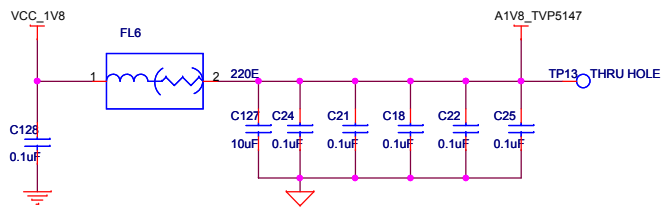

REV NO.	NATURE OF CHANGE	APPROVED BY	DATE	 Mistral Solutions [P] Ltd. #60 Adarsh regent, 100 Feet Ring Road, Domlur Extension Bangalore 560 071, Ph : +91-80-30912600, Fax : +91-80-2535 6444		Title	TVP5147 POWER	
				Drawn by: Mistral Design Team Date: Monday, May 31, 2010	Approved by: Mistral Approval Team Date: Saturday, November 12, 2011	Size	Document Number	Rev
				Design file path:		B	MS_TI_DM814x_EXP_IO_REVD_SCH	D
						Date:	Friday, October 28, 2011	Sheet 21 of 32

5

4

3

2

1

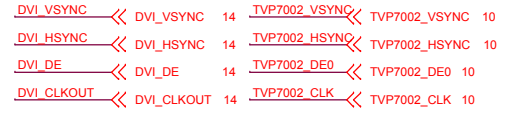
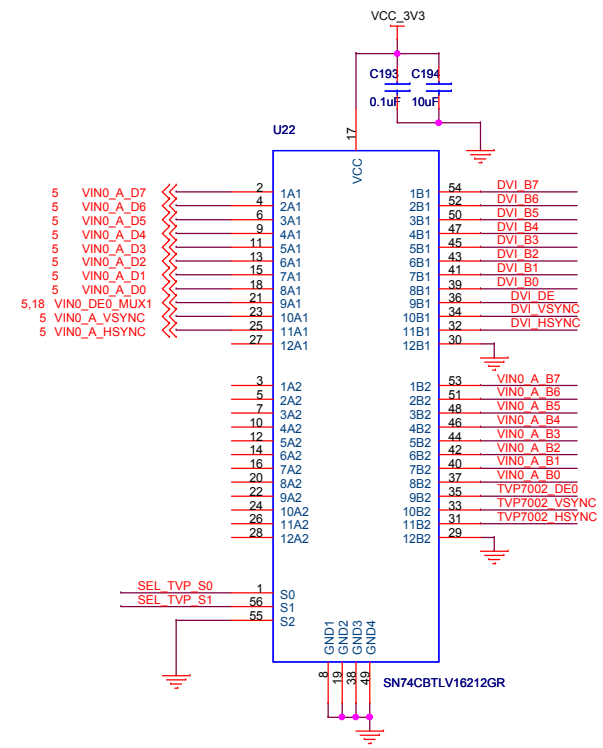
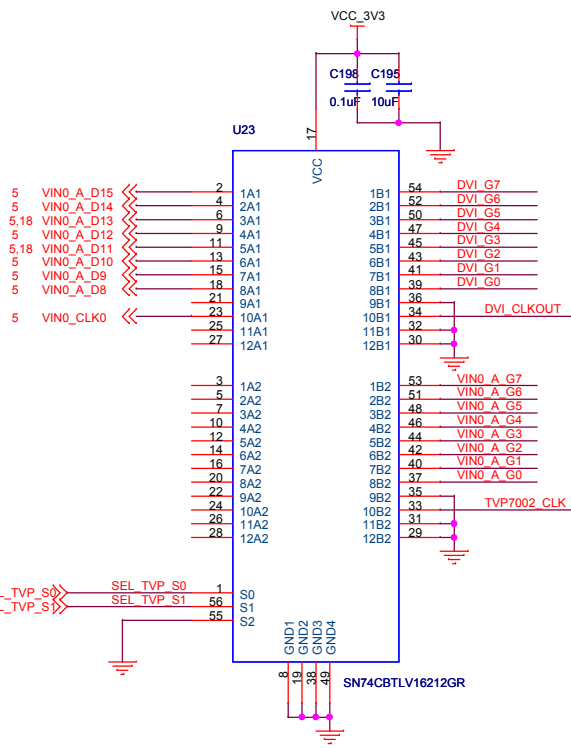
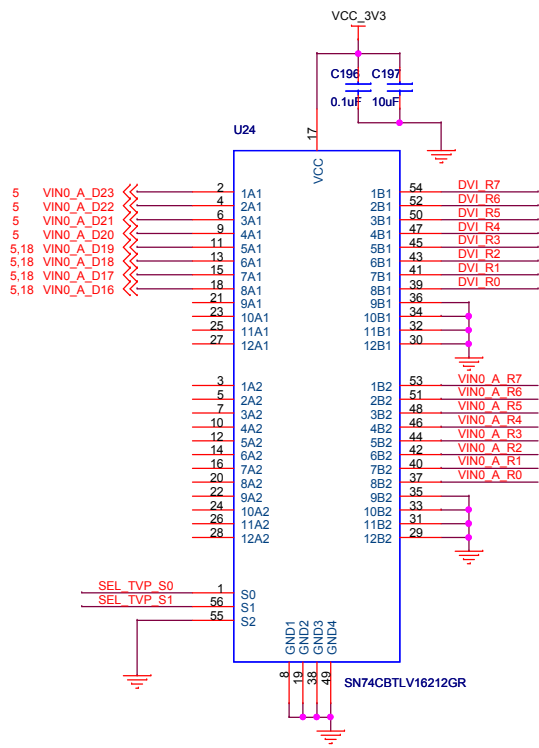

Camera is muxed with VIN0 (TVP7002 & si1161).
So any one will be selected among these

S2	S1	S0	A1	A2
	(SEL_TVP_S1)	(SEL_TVP_S0)	Z	Z
L	L	L	Z	Z
L	L	H	B1	Z
L	H	L	B2	Z

CAMERA MODE(Default)
DVI SELECTED
TVP7002 SELECTED

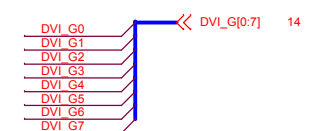
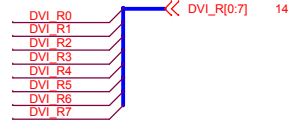
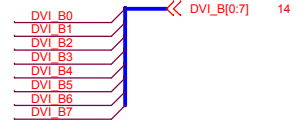
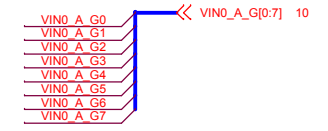
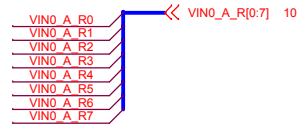
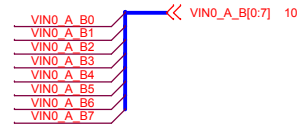

REV NO.	NATURE OF CHANGE	APPROVED BY	DATE	Mistral Solutions [P] Ltd. #60 Adarsh regent,100 Feet Ring Road, Domlur Extension Bangalore 560 071, Ph : +91-80-30912600, Fax :+91-80-2535 6444		Title	VINO MUXING	
				Drawn by: Mistral Design Team	Approved by: Mistral Approval Team	Size	Document Number	
				Date: Monday, May 31, 2010	Date: Saturday, November 12, 2011	B	MS_TI_DM814x_EXP_IO_REVD_SCH	
				Design file path:		Date:	Friday, October 28, 2011	Sheet 22 of 32

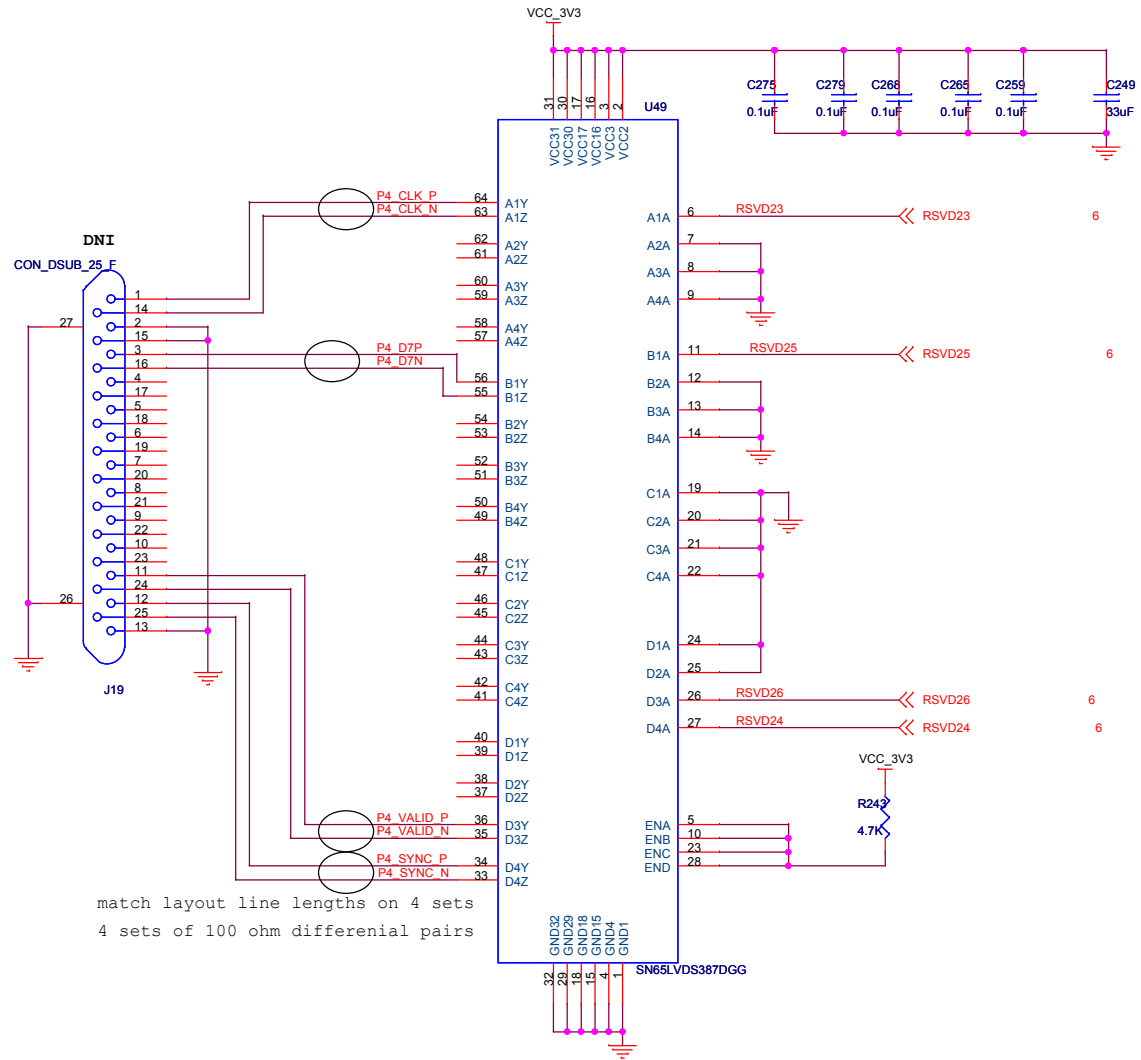

REV NO.	NATURE OF CHANGE	APPROVED BY	DATE	Mistral Solutions [P] Ltd. MISTRAL #60 Adarsh regent,100 Feet Ring Road, Domlur Extension Bangalore 560 071, Ph : +91-80-30912600, Fax :+91-80-2535 6444		Title	RESERVE0	
				Drawn by: Mistral Design Team	Approved by: Mistral Approval Team	Size	Document Number	Rev
				Date: Monday, May 31, 2010	Date: Saturday, November 12, 2011	B	MS_TI_DM814x_EXP_IO_REVD_SCH	D
				Design file path:		Date:	Friday, October 28, 2011	Sheet 23 of 32

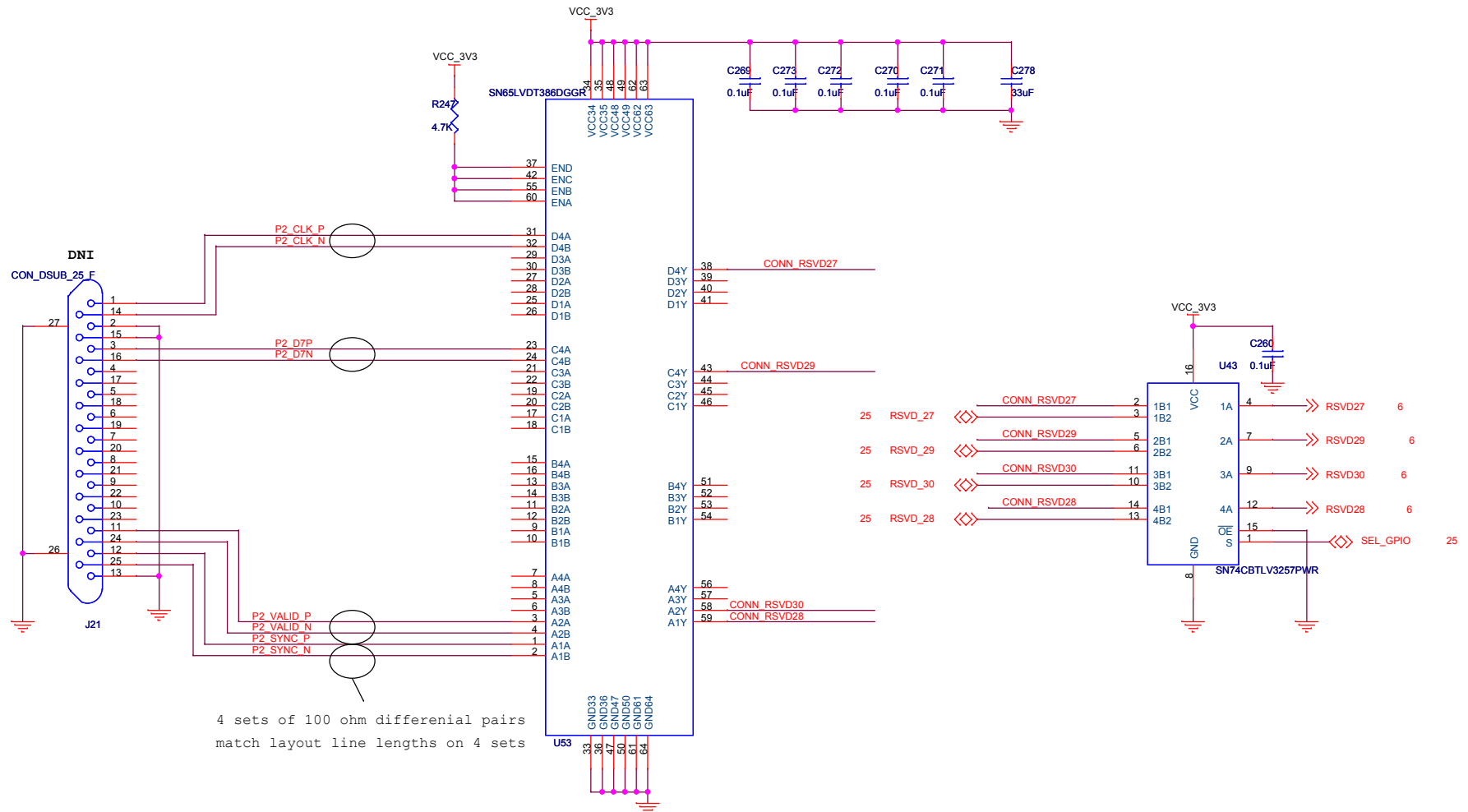

REV NO.	NATURE OF CHANGE	APPROVED BY	DATE	Mistral Solutions [P] Ltd.		Title	Size	Document Number	Rev
				Mistral Solutions [P] Ltd. #60 Adarsh regent, 100 Feet Ring Road, Domlur Extension Bangalore 560 071, Ph : +91-80-30912600, Fax : +91-80-2535 6444		RESERVE1	B	MS_TI_DM814x_EXP_IO_REVD_SCH	D
				Drawn by: Mistral Design Team Date: Monday, May 31, 2010	Approved by: Mistral Approval Team Date: Saturday, November 12, 2011	Date: Friday, October 28, 2011	Sheet 24 of 32		

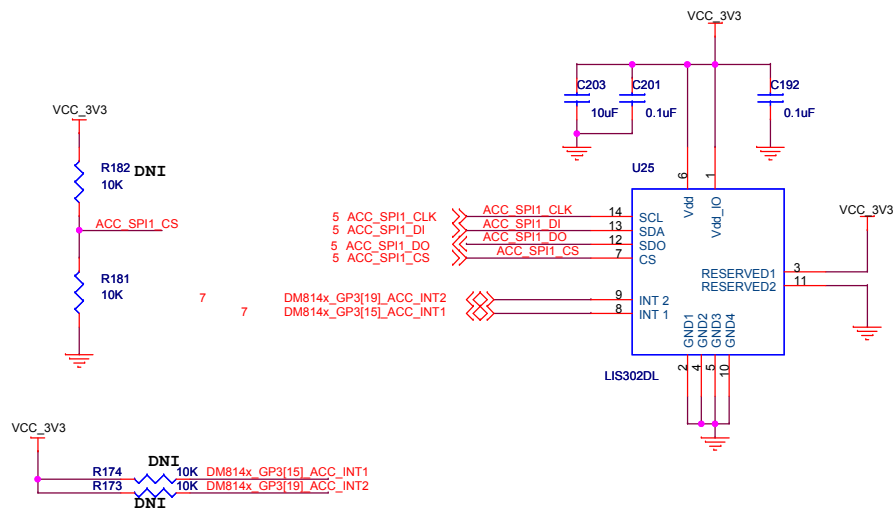
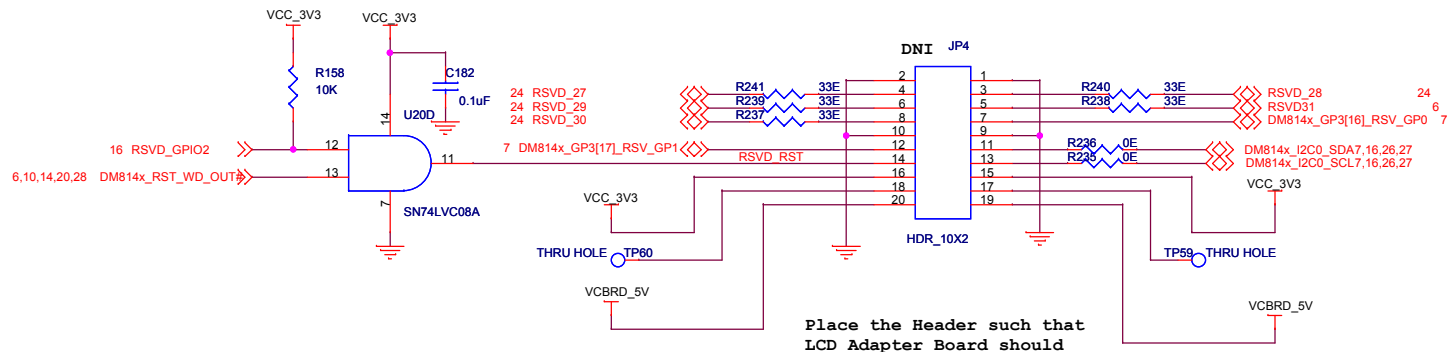

REV NO.	NATURE OF CHANGE	APPROVED BY	DATE	Mistral Solutions [P] Ltd. #60 Adarsh regent, 100 Feet Ring Road, Domlur Extension Bangalore 560 071, Ph : +91-80-30912600, Fax : +91-80-2535 6444		Title	Size	Document Number	Rev
				Drawn by: Mistral Design Team	Approved by: Mistral Approval Team	ACCELEROMETER	B	MS_TI_DM814x_EXP_IO_REVD_SCH	D
				Date: Monday, May 31, 2010	Date: Saturday, November 12, 2011		Date: Friday, October 28, 2011	Sheet 25 of 32	

BOARD ID VERSION EEPROM

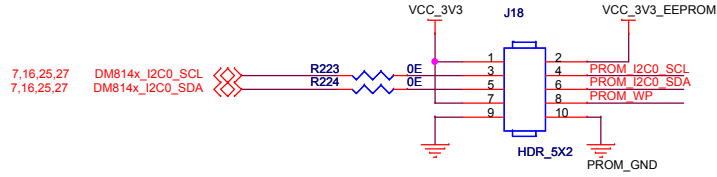

TO GET THE DEFAULT CONNECTION FROM DM814x/AM387x PLACE THE SHORT LINKS BETWEEN 1-2, 3-4, 5-6 AND 9-10 ONLY.
DO NOT SHORT FOR 7-8

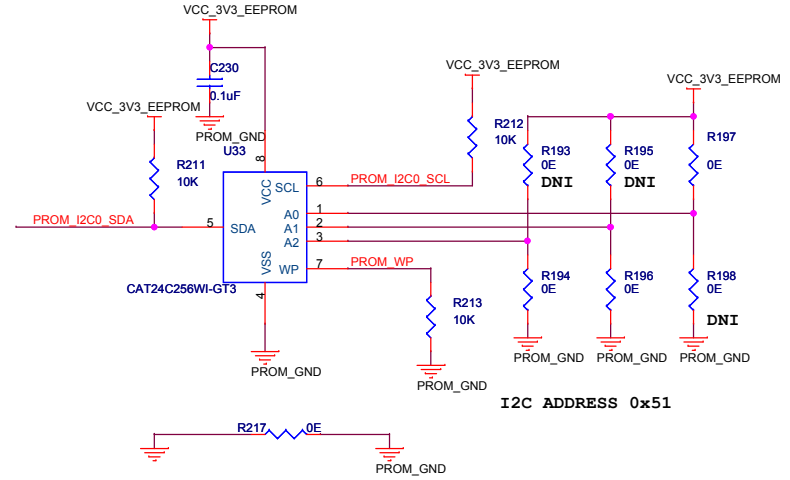

I2C ADDRESS 0x51

REV NO.	NATURE OF CHANGE	APPROVED BY	DATE	Mistral Solutions [P] Ltd. #60 Adarsh regent, 100 Feet Ring Road, Domlur Extension Bangalore 560 071, Ph : +91-80-30912600, Fax : +91-80-2535 6444		Title	Size	Document Number	Rev
				Drawn by: Mistral Design Team	Approved by: Mistral Approval Team	BOARD ID EEPROM	B	MS_TI_DM814x_EXP_IO_REVD_SCH	D
			Date: Monday, May 31, 2010	Date: Saturday, November 12, 2011	Date: Friday, October 28, 2011				Sheet 26 of 32
			Design file path:						

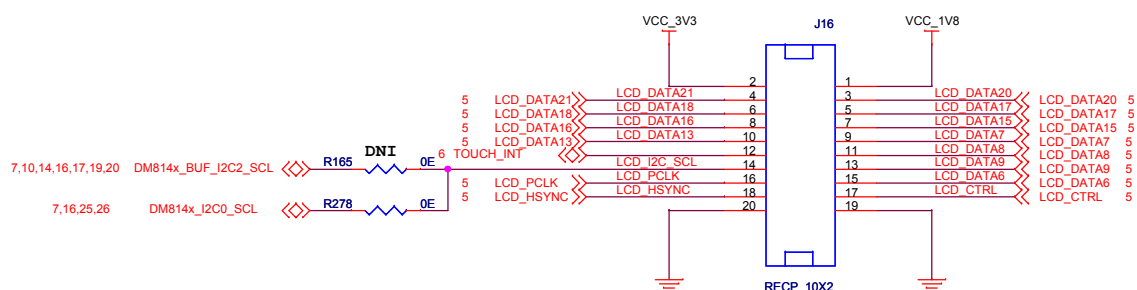
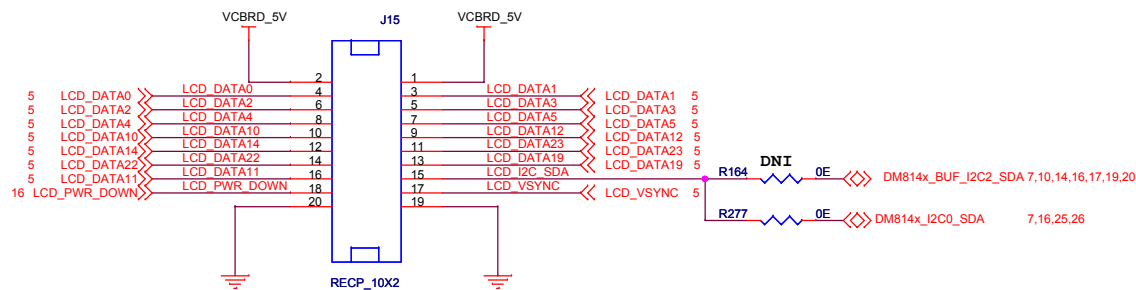

REV NO.	NATURE OF CHANGE	APPROVED BY	DATE	Mistral Solutions [P] Ltd. #60 Adarsh regent,100 Feet Ring Road, Domlur Extension Bangalore 560 071, Ph : +91-80-30912600, Fax :+91-80-2535 6444		Title	Size	Document Number	Rev
				Drawn by: Mistral Design Team	Approved by: Mistral Approval Team	LCD & TOUCH SCREEN	B	MS_TI_DM814x_EXP_IO_REVD_SCH	D
				Date: Monday, May 31, 2010	Date: Saturday, November 12, 2011				
				Design file path:		Date: Friday, October 28, 2011		Sheet 27 of 32	

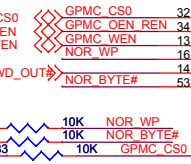
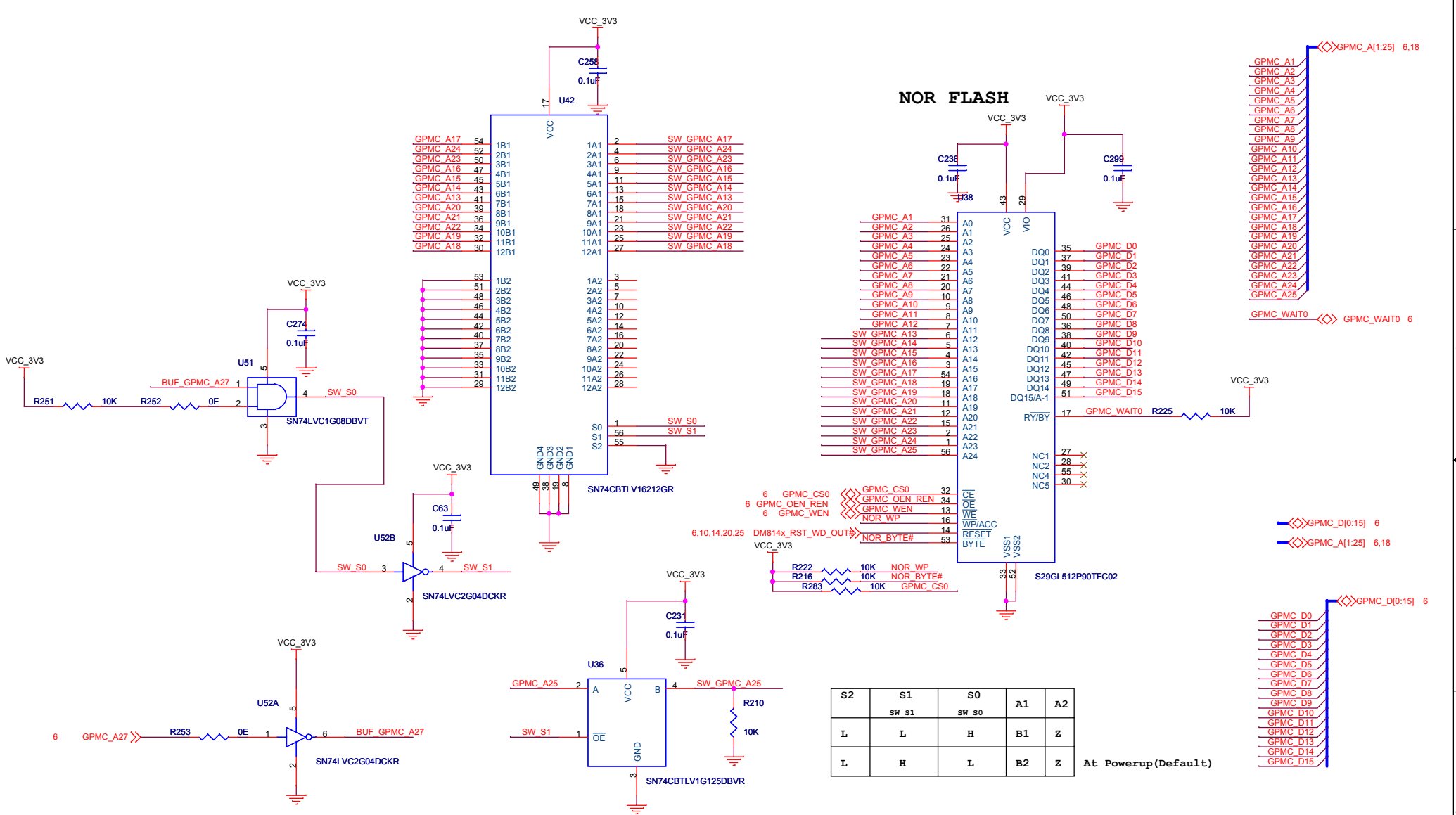

S2	S1	S0	A1	A2
	SW_S1	SW_S0	B1	Z
L	L	H	B1	Z
L	H	L	B2	Z

At Powerup(Default)

REV NO.	NATURE OF CHANGE	APPROVED BY	DATE	Mistral Solutions [P] Ltd.		Title	
				Mistral Solutions [P] Ltd. #60 Adarsh regent, 100 Feet Ring Road, Domlur Extension Bangalore 560 071, Ph : +91-80-30912600, Fax : +91-80-2535 6444		NOR FLASH	
				Drawn by: Mistral Design Team Date: Monday, May 31, 2010	Approved by: Mistral Approval Team Date: Saturday, November 12, 2011	Size: B Document Number: MS_TI_DM814x_EXP_IO_REVD_SCH	Rev: D
				Design file path:		Date: Friday, October 28, 2011	Sheet 28 of 32

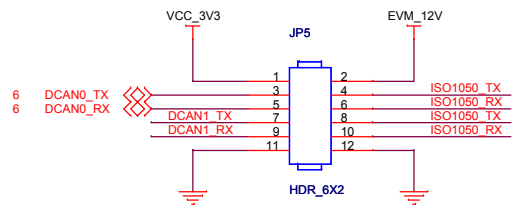

Place jumper in 3-4 and 5-6 (DCAN0 -Default ON)

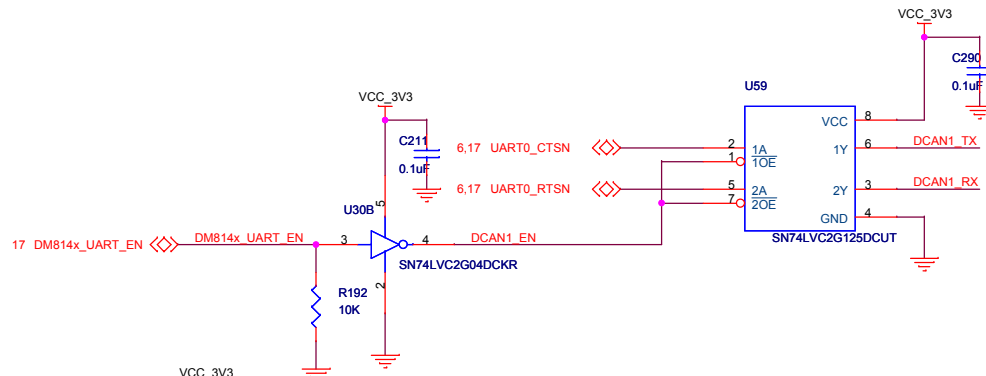
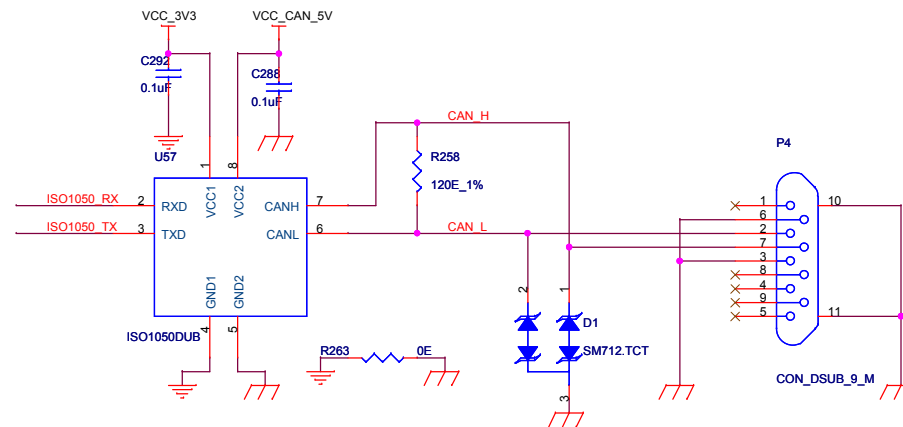

CEN_GP1[8]_UART_EN
LOW = UART ENABLE (DEFAULT)
HIGH = DCAN1 ENABLE

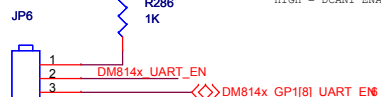

HDR_3X1

Place jumper in 2 & 3 (Default)

CEN_GP1[8]_UART_EN is muxed with Base EVM's I/O expander Interrupt pin.

In case of GPIO clashing with Base EVM, Normal operation: Do not use jumper. (UART selected)
Place jumper between 1 & 2 for DCAN select.

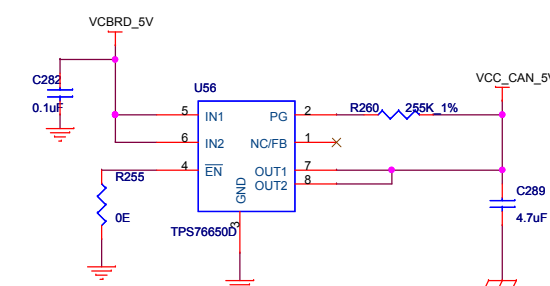

REV NO.	NATURE OF CHANGE	APPROVED BY	DATE	Mistral Solutions [P] Ltd. #60 Adarsh regent, 100 Feet Ring Road, Domlur Extension Bangalore 560 071, Ph : +91-80-30912600, Fax : +91-80-2535 6444		Title	Size	Document Number	Rev
				Drawn by: Mistral Design Team	Approved by: Mistral Approval Team	DCAN INTERFACE	B	MS_TI_DM814x_EXP_IO_REVD_SCH	D
				Date: Monday, May 31, 2010	Date: Saturday, November 12, 2011				
				Design file path:		Date: Friday, October 28, 2011		Sheet 29 of 32	

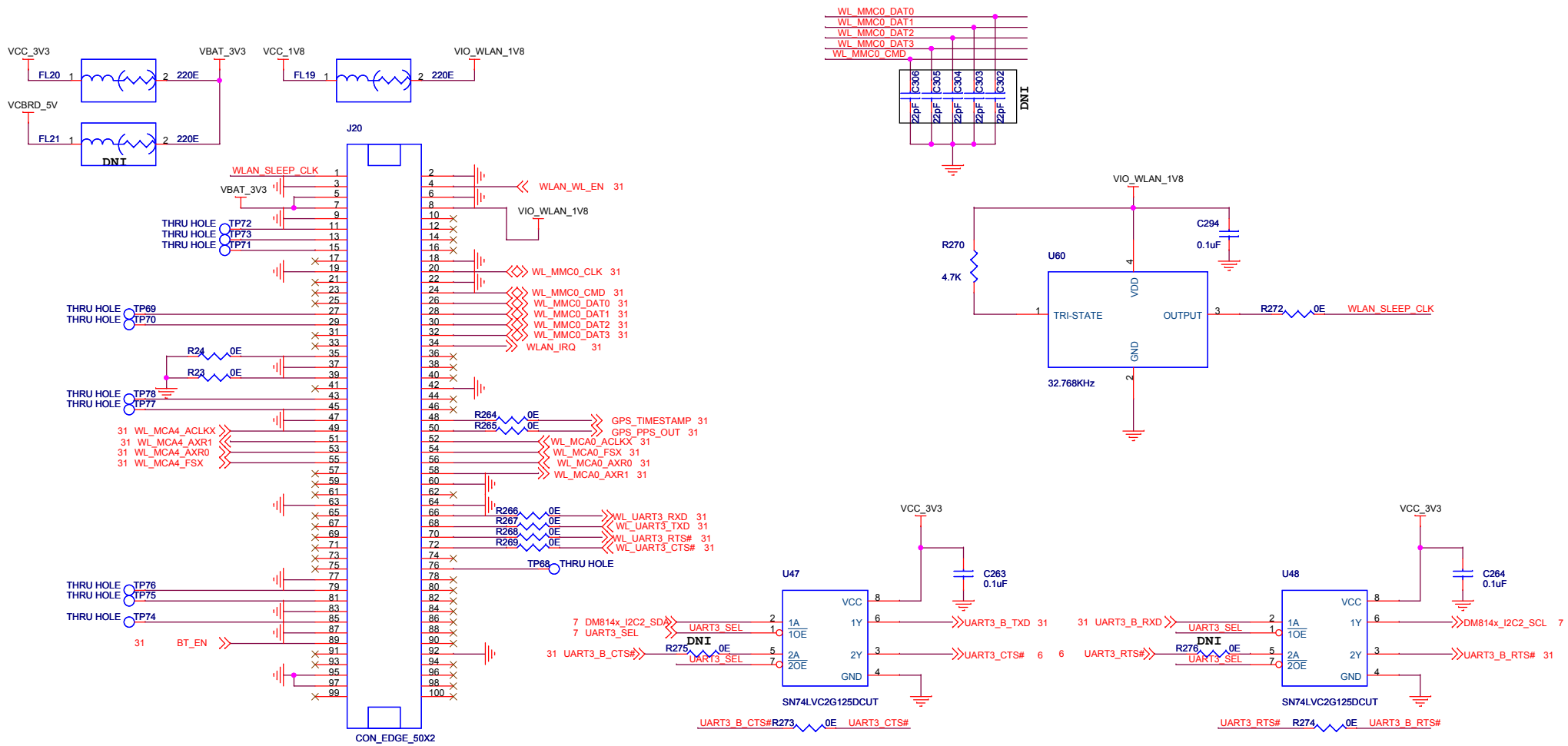

REV NO.	NATURE OF CHANGE	APPROVED BY	DATE	Mistral Solutions [P] Ltd. #60 Adarsh regent, 100 Feet Ring Road, Domlur Extension Bangalore 560 071, Ph : +91-80-30912600, Fax : +91-80-2535 6444		Title
				Drawn by: Mistral Design Team Date: Monday, May 31, 2010		COM7 CONNECTOR - WLAN & BT
				Design file path:	Size: B	Document Number: MS_TI_DM814x_EXP_IO_REVD_SCH Date: Friday, October 28, 2011
					Rev: D	Sheet 30 of 32

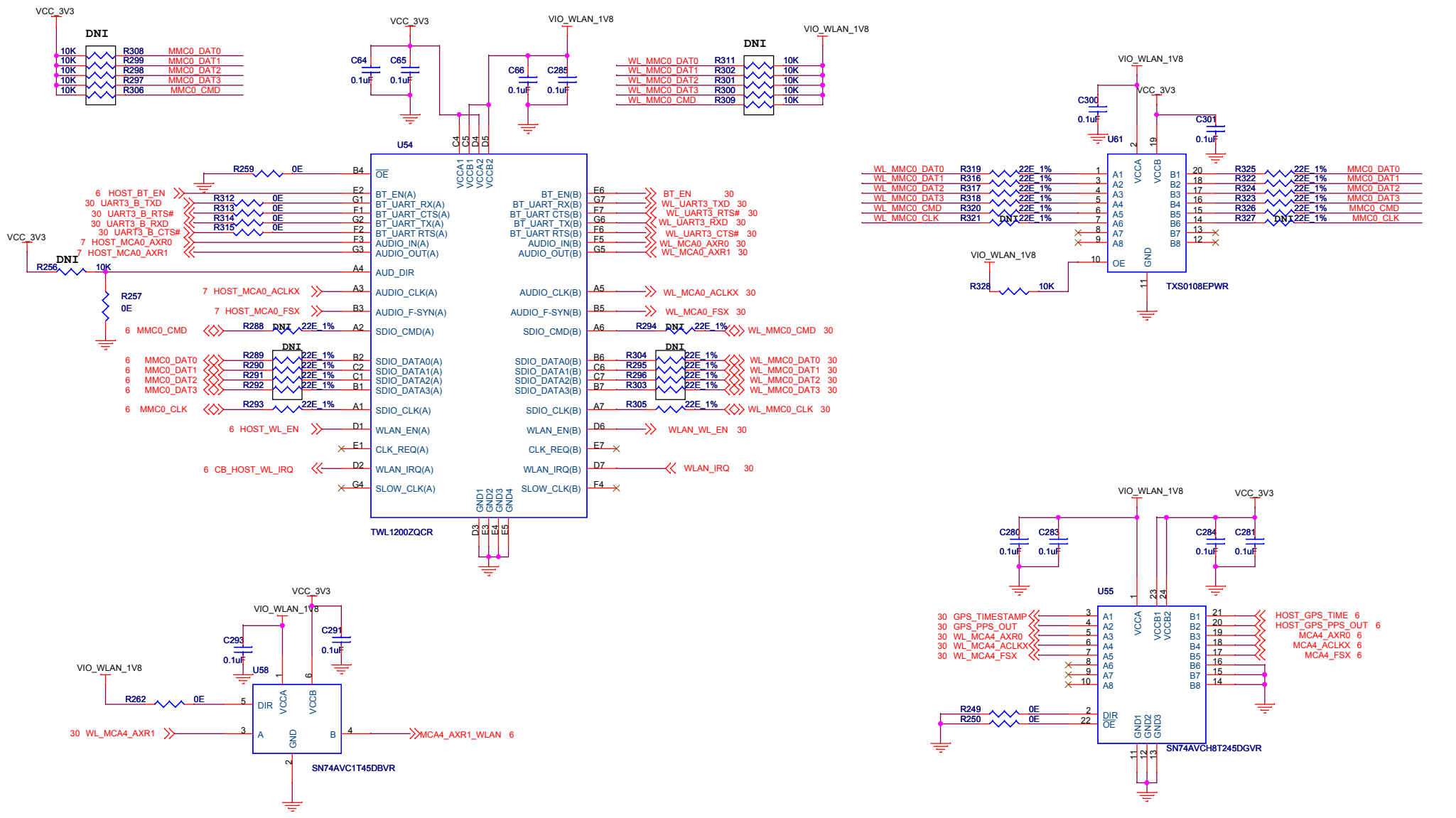

REV NO.	NATURE OF CHANGE	APPROVED BY	DATE	Mistral Solutions [P] Ltd.		Title	
				Mistral Solutions [P] Ltd. #60 Adarsh regent, 100 Feet Ring Road, Domlur Extension Bangalore 560 071, Ph : +91-80-30912600, Fax : +91-80-2535 6444		WLAN MODULE BUFFERS	
				Drawn by: Mistral Design Team Date: Monday, May 31, 2010	Approved by: Mistral Approval Team Date: Saturday, November 12, 2011	Size: B Document Number: MS_TI_DM814x_EXP_IO_REVD_SCH	Rev: D Date: Friday, October 28, 2011
				Design file path:			Sheet 31 of 32

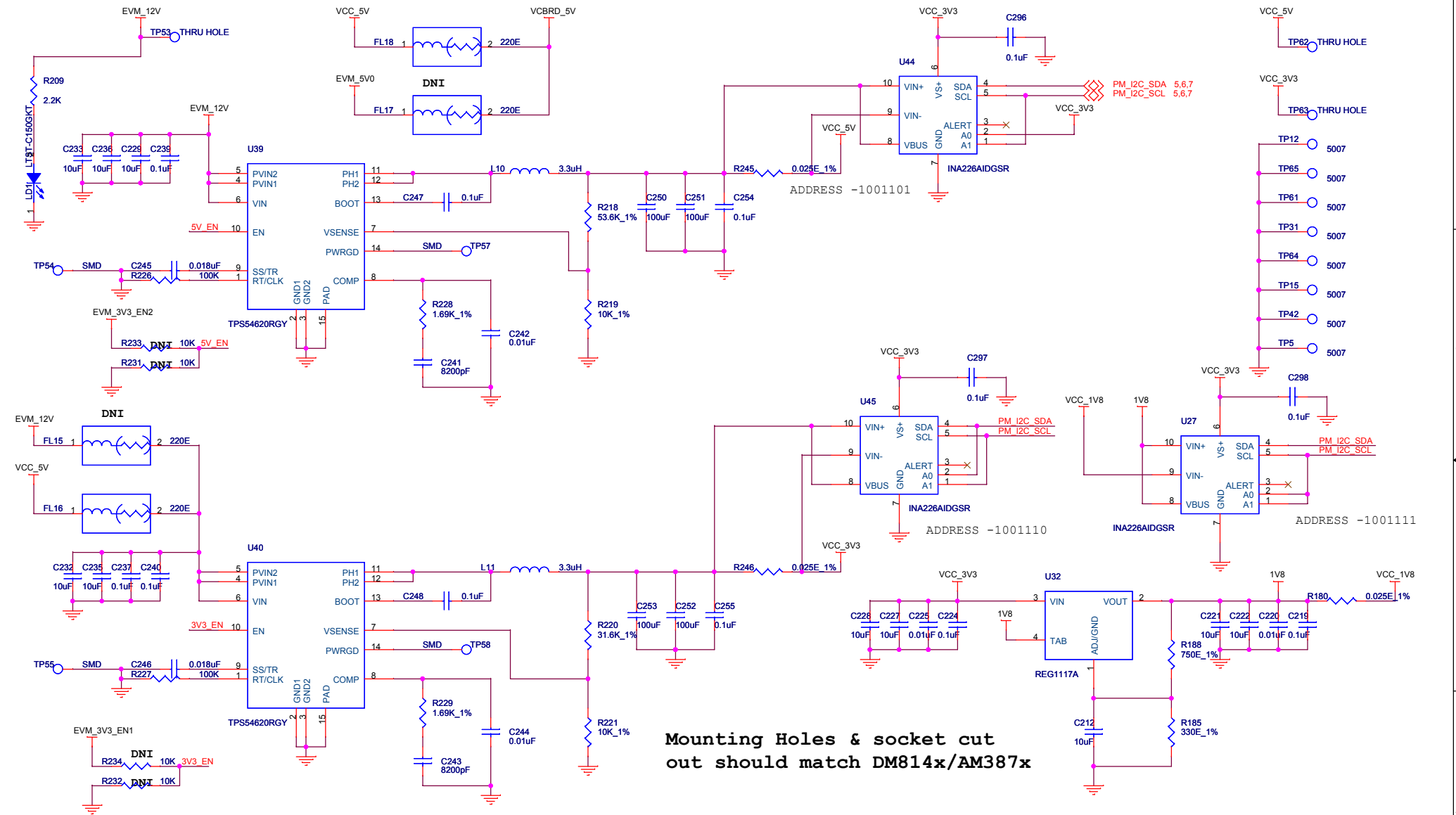

**Mounting Holes & socket cut
out should match DM814x/AM387x**

REV NO.	NATURE OF CHANGE	APPROVED BY	DATE	Mistral Solutions [P] Ltd. #60 Adarsh regent, 100 Feet Ring Road, Domlur Extension Bangalore 560 071, Ph : +91-80-30912600, Fax : +91-80-2535 6444		Title	Size	Document Number	Rev
				Drawn by: Mistral Design Team	Approved by: Mistral Approval Team	POWER SUPPLY	B	MS_TI_DM814x_EXP_IO_REVD_SCH	D
				Date: Monday, May 31, 2010	Date: Saturday, November 12, 2011				
				Design file path:		Date: Friday, October 28, 2011	Sheet 32 of 32		