

File	<Title>	
Size	Document Number	Rev
C	<Doc>	<Rev>
Date:	Wednesday, March 26, 2014	Sheet 1 of 13

5V input

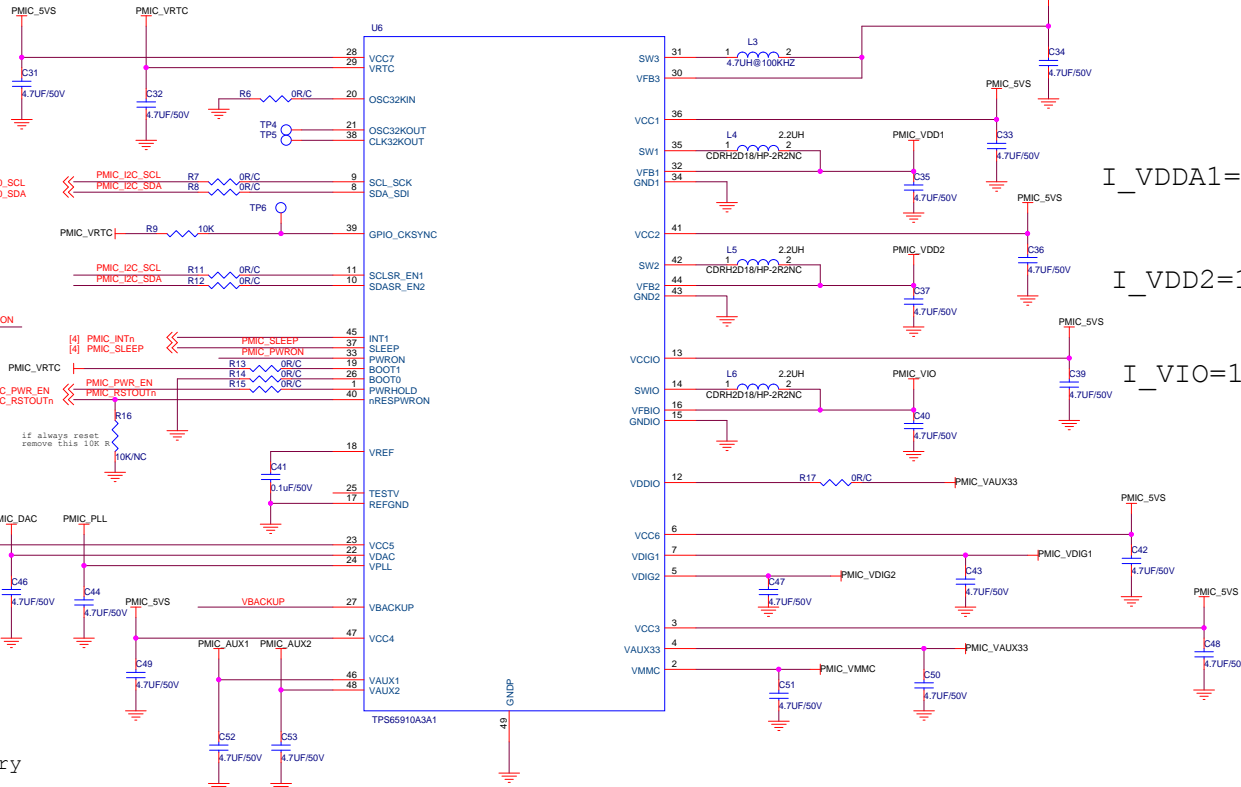

Imax is low
not use



I_VDDA1=1.5A

I_VDD2=1.5A

I_VIO=1A

Connect Battery

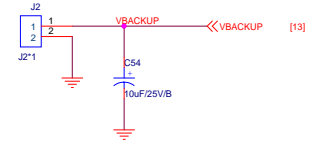

Use L With output

File	<Title>		Rev
Size	Document Number		<Doc>
C			
Date:	Wednesday, March 26, 2014	Sheet	2 of 13

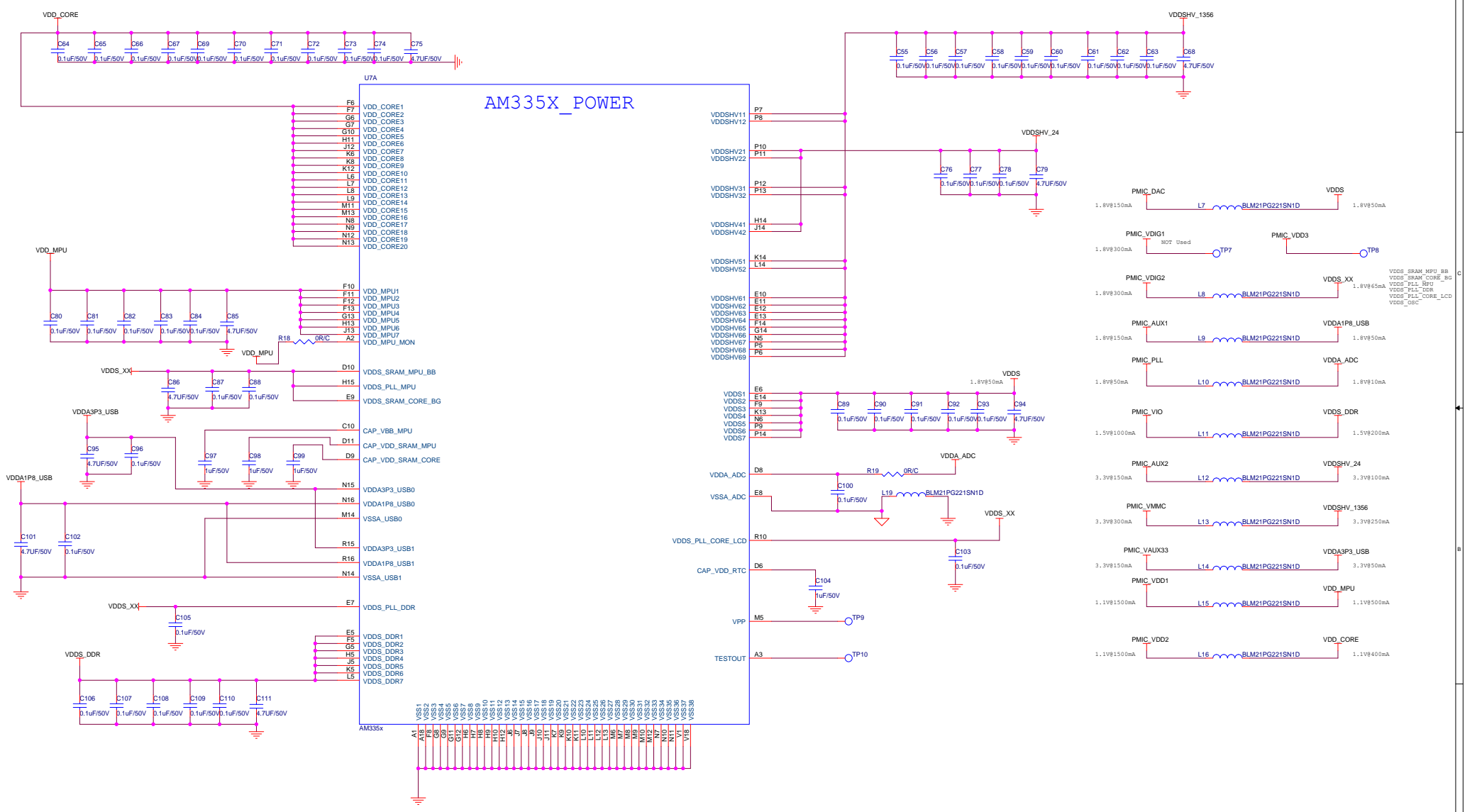

AM335X_POWER

- U7A**
- F6 VDD_CORE1
 - F7 VDD_CORE2
 - G6 VDD_CORE3
 - G7 VDD_CORE4
 - H11 VDD_CORE5
 - J12 VDD_CORE6
 - K6 VDD_CORE7
 - K8 VDD_CORE8
 - K12 VDD_CORE9
 - L6 VDD_CORE10
 - L9 VDD_CORE11
 - L8 VDD_CORE12
 - L3 VDD_CORE13
 - M11 VDD_CORE14
 - M13 VDD_CORE15
 - N9 VDD_CORE16
 - N9 VDD_CORE17
 - N12 VDD_CORE18
 - N12 VDD_CORE19
 - N13 VDD_CORE20
- AM335X**
- A1 VSS1
 - A6 VSS2
 - A8 VSS3
 - A9 VSS4
 - B5 VSS5
 - B5 VSS6
 - B5 VSS7
 - B5 VSS8
 - B5 VSS9
 - B5 VSS10
 - B5 VSS11
 - B5 VSS12
 - B5 VSS13
 - B5 VSS14
 - B5 VSS15
 - B5 VSS16
 - B5 VSS17
 - B5 VSS18
 - B5 VSS19
 - B5 VSS20
 - B5 VSS21
 - B5 VSS22
 - B5 VSS23
 - B5 VSS24
 - B5 VSS25
 - B5 VSS26
 - B5 VSS27
 - B5 VSS28
 - B5 VSS29
 - B5 VSS30
 - B5 VSS31
 - B5 VSS32
 - B5 VSS33
 - B5 VSS34
 - B5 VSS35
 - B5 VSS36
 - B5 VSS37
 - B5 VSS38

File		<Title>
Size	Document Number	Rev
C	<Doc>	<Rev>
Date:	Wednesday, March 26, 2014	Sheet 3 of 13

VDDS_RTC 供电方案。TPS178

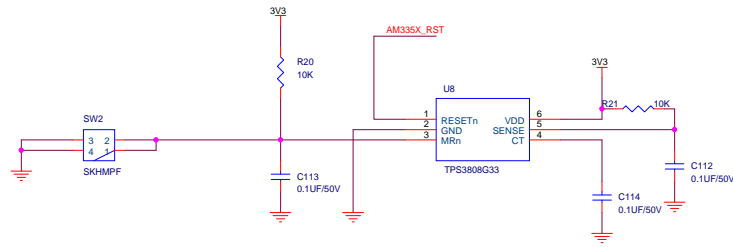

[11] AM335X_PWRONRStn << AM335X_PWRONRStn

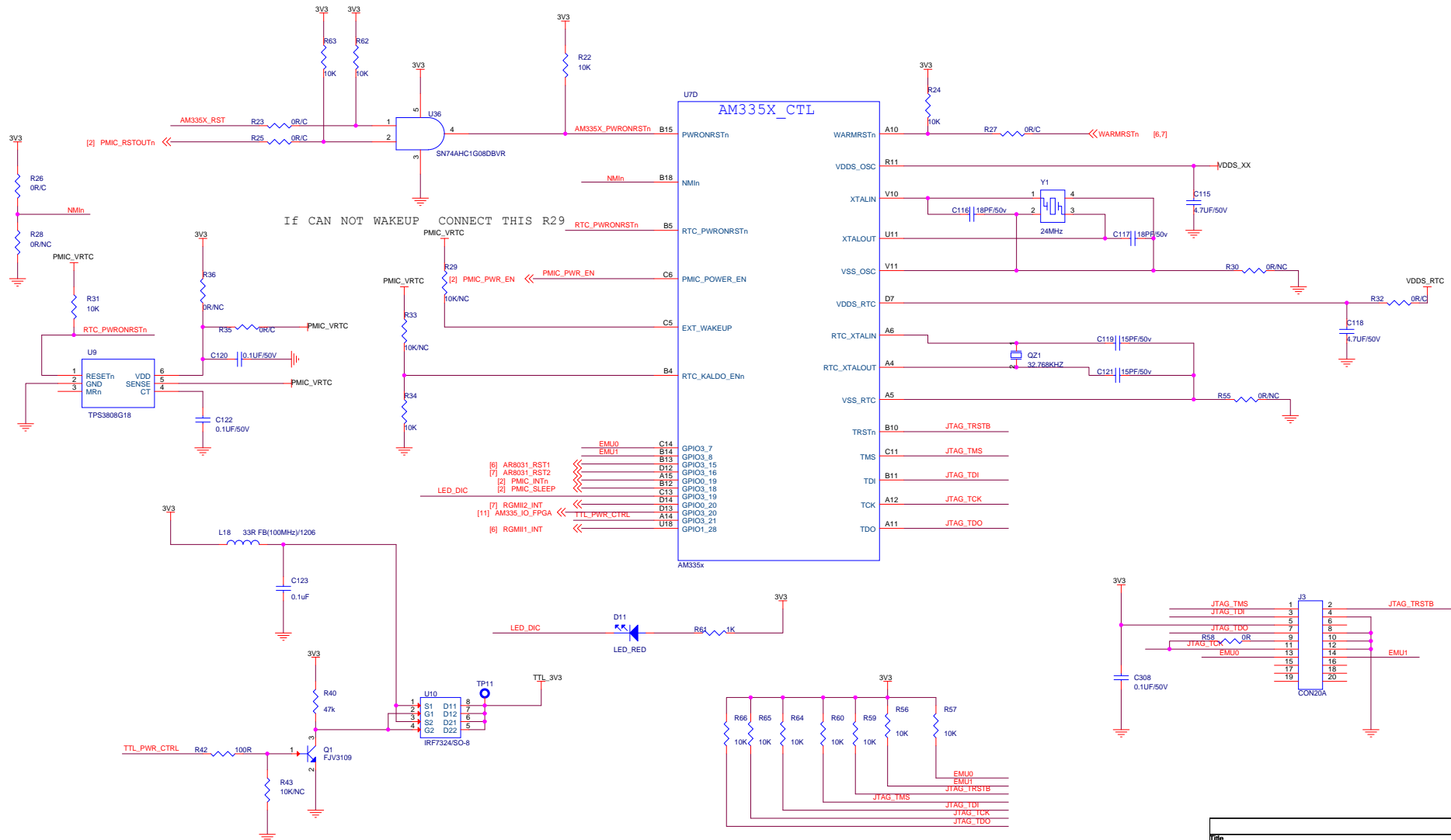

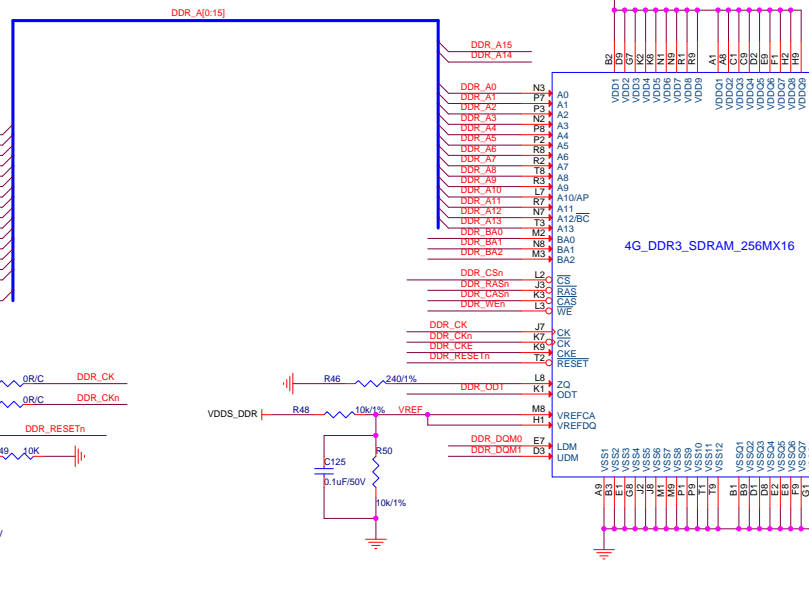
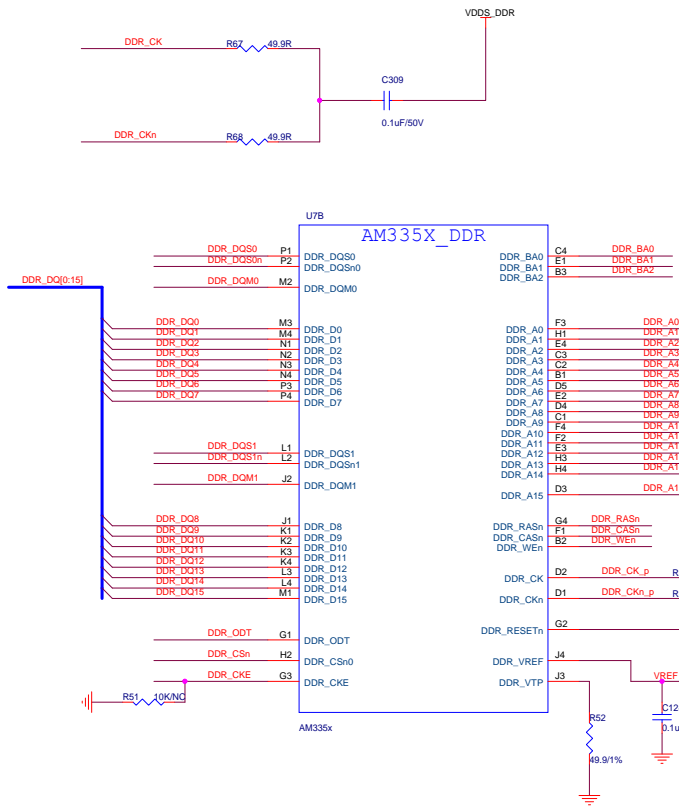

swapping if pcb need

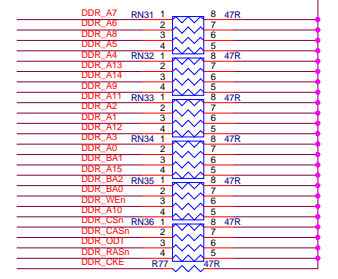
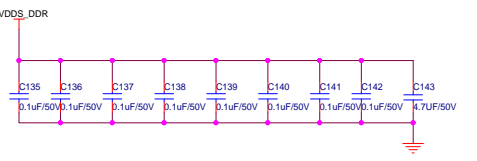
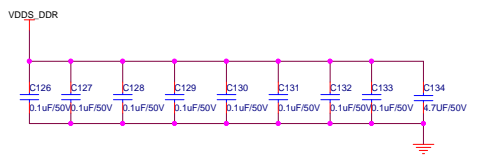

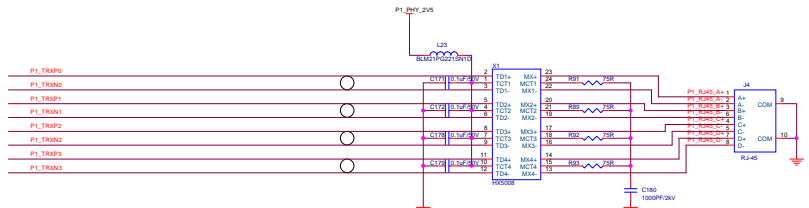
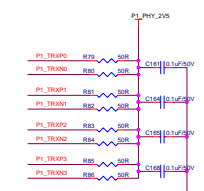
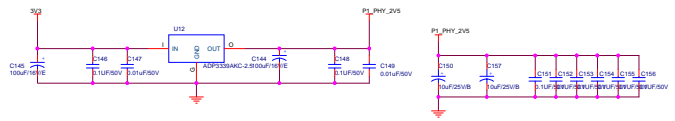
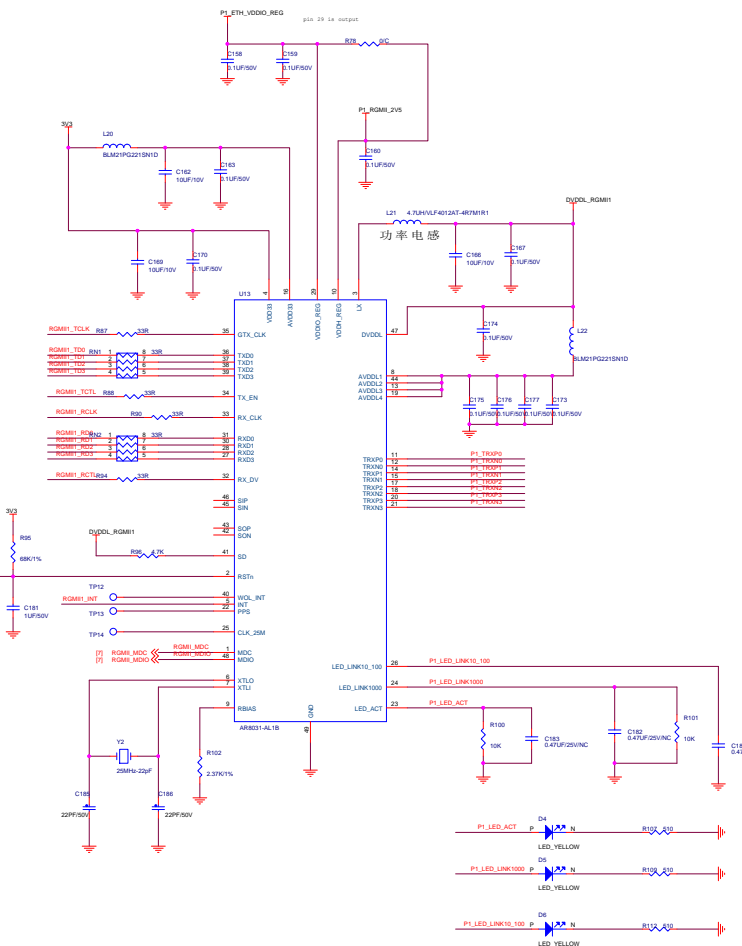
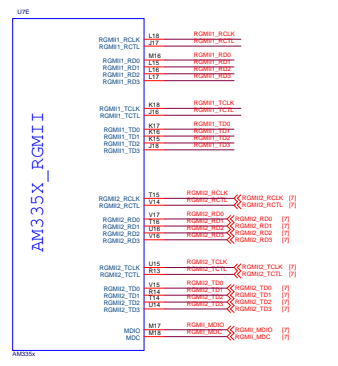

DIFFERENTIAL PAIR
100Ω DIFFERENTIAL
IMPEDANCE
SHORT AND STRAIGHT AS
POSSIBLE,
MINIMUM NUMBER OF VIAS

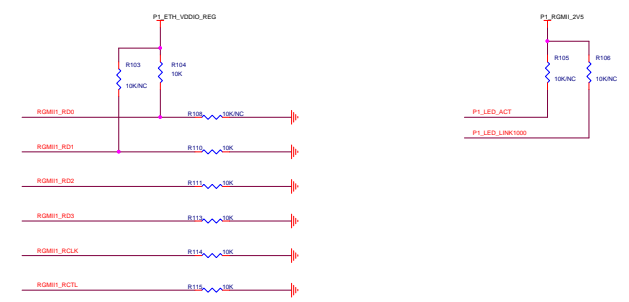

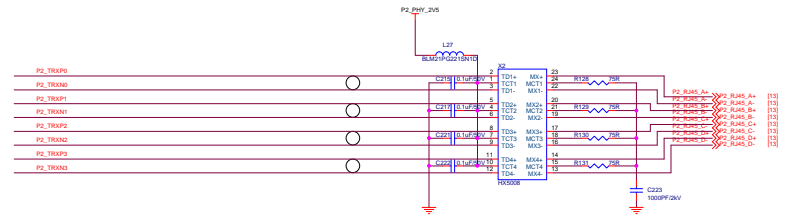
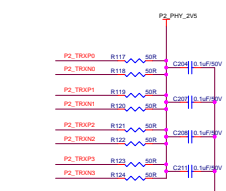
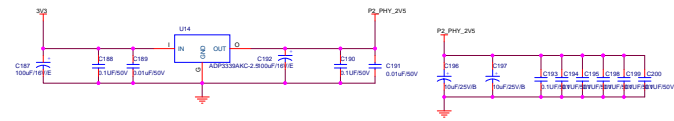
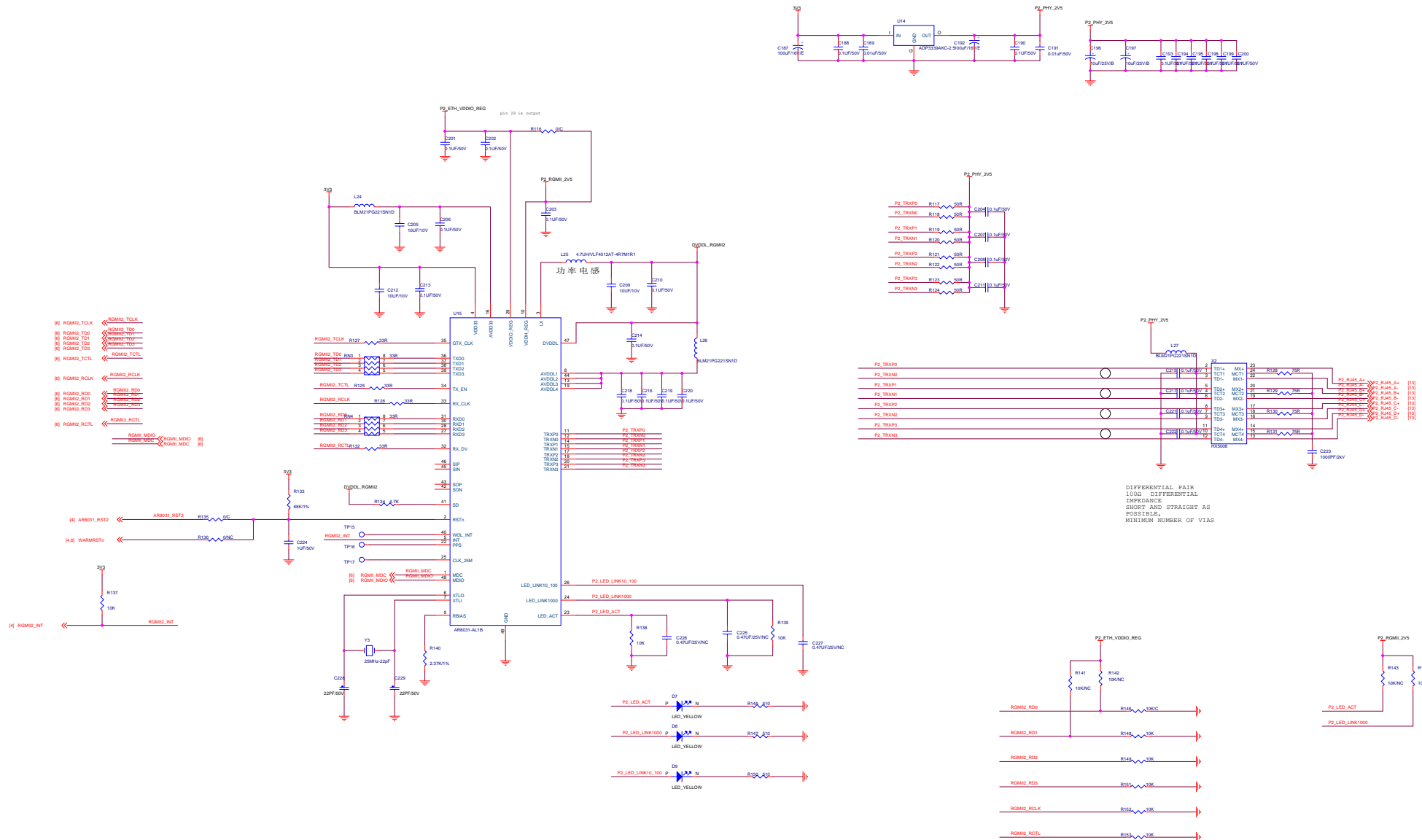

DIFFERENTIAL PAIR
100Ω DIFFERENTIAL
IMPEDANCE
SERVICED STRAIGHT AS
POSSIBLE,
MINIMUM NUMBER OF VIAS

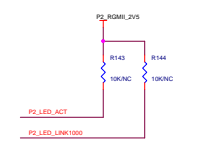
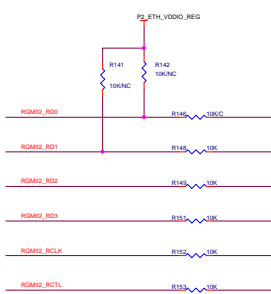

File	c:\files	
Rev	Document Number	REV
D	Doc	Doc
Date	Wednesday, March 24, 2014	Page 7 of 13

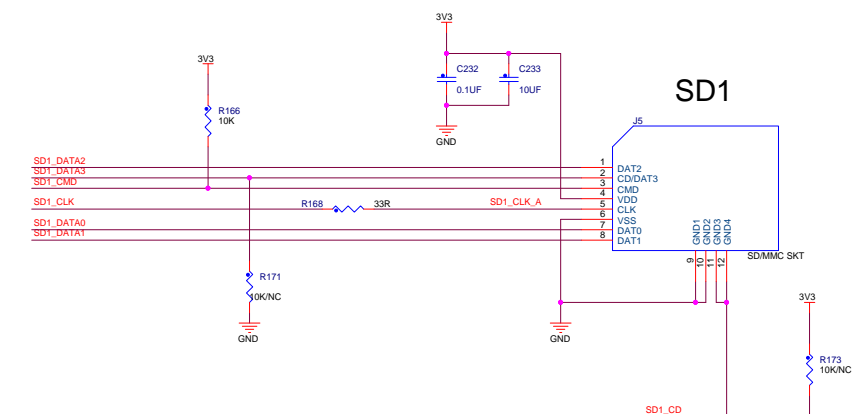
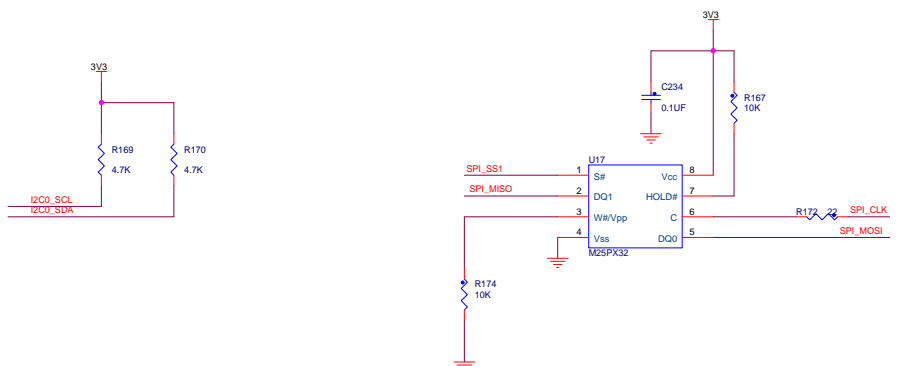
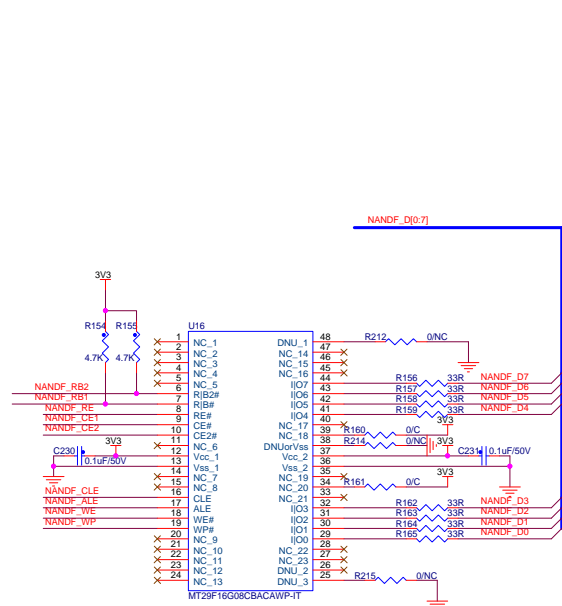
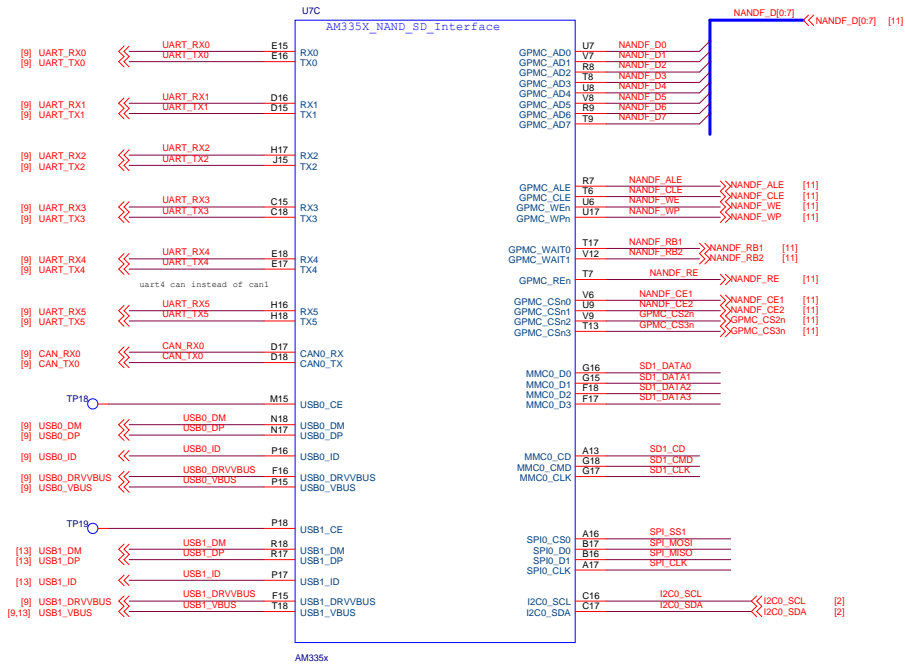

File	<Title>		
Size	Document Number		Rev
C	<Doc>		<Rev Code>
Date:	Wednesday, March 26, 2014	Sheet	8 of 13

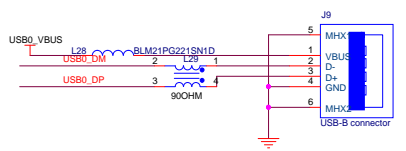
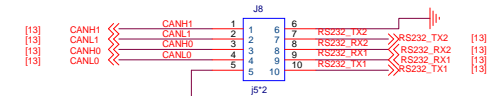
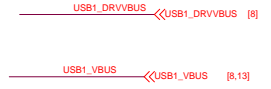
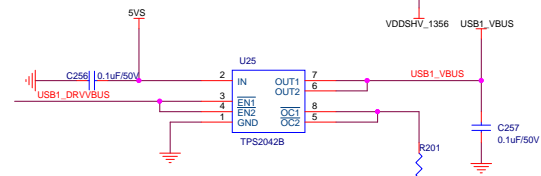
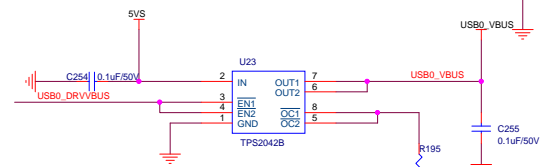
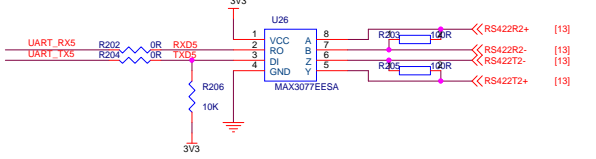
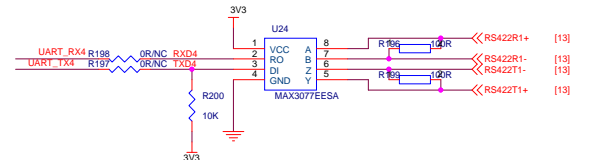
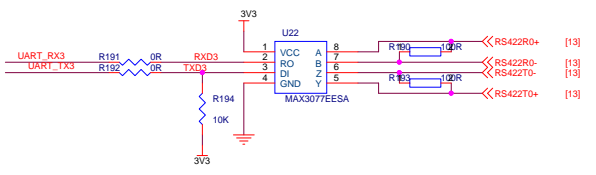
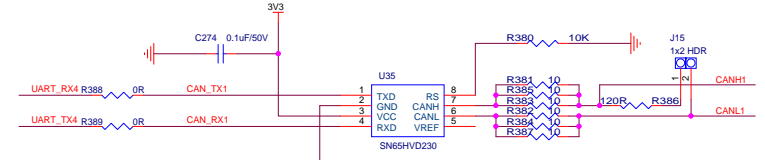
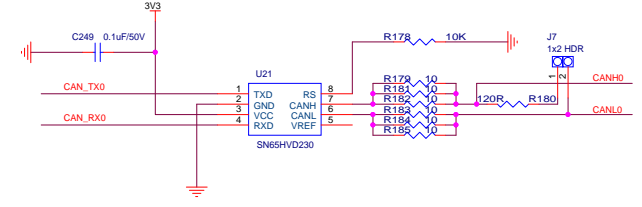
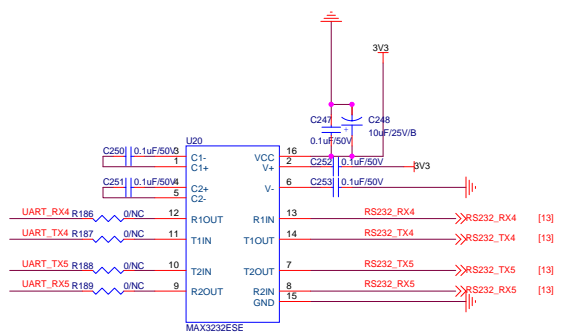
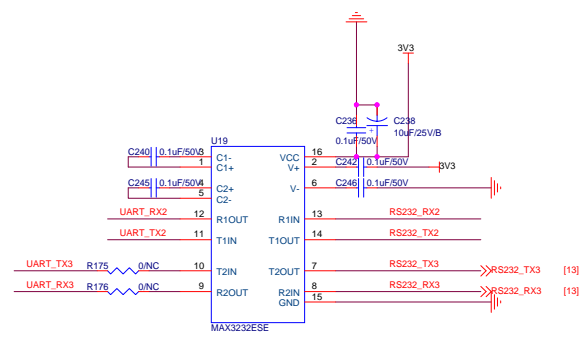
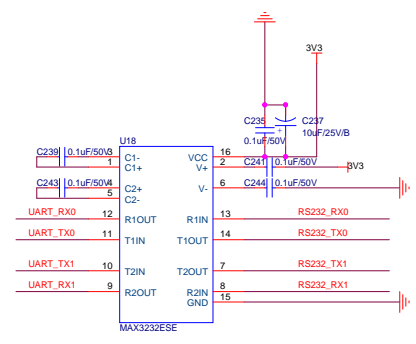
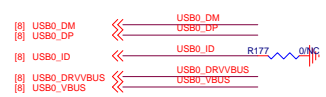
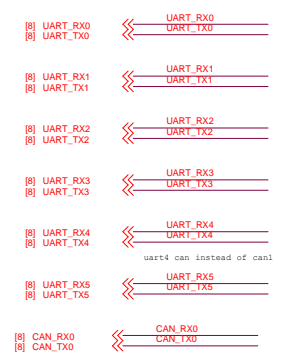

File	<Title>	Rev	<Rev Code>
Size	Document Number		
C	<Doc>		
Date:	Wednesday, March 26, 2014	Sheet	8 of 13

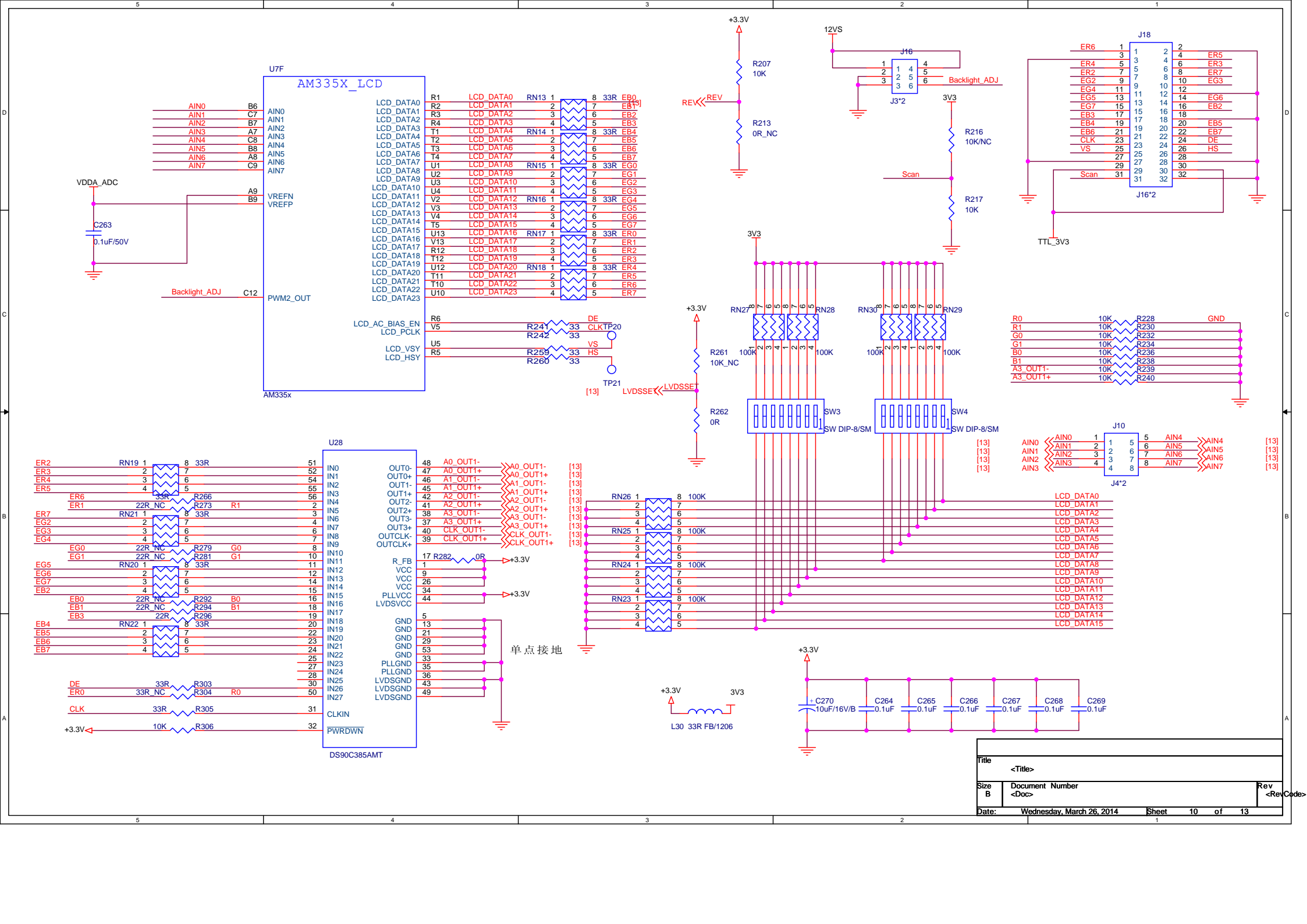

Title		<Title>
Size	Document Number	Rev
B	<Doc>	<RevCode>
Date:	Wednesday, March 26, 2014	Sheet 10 of 13

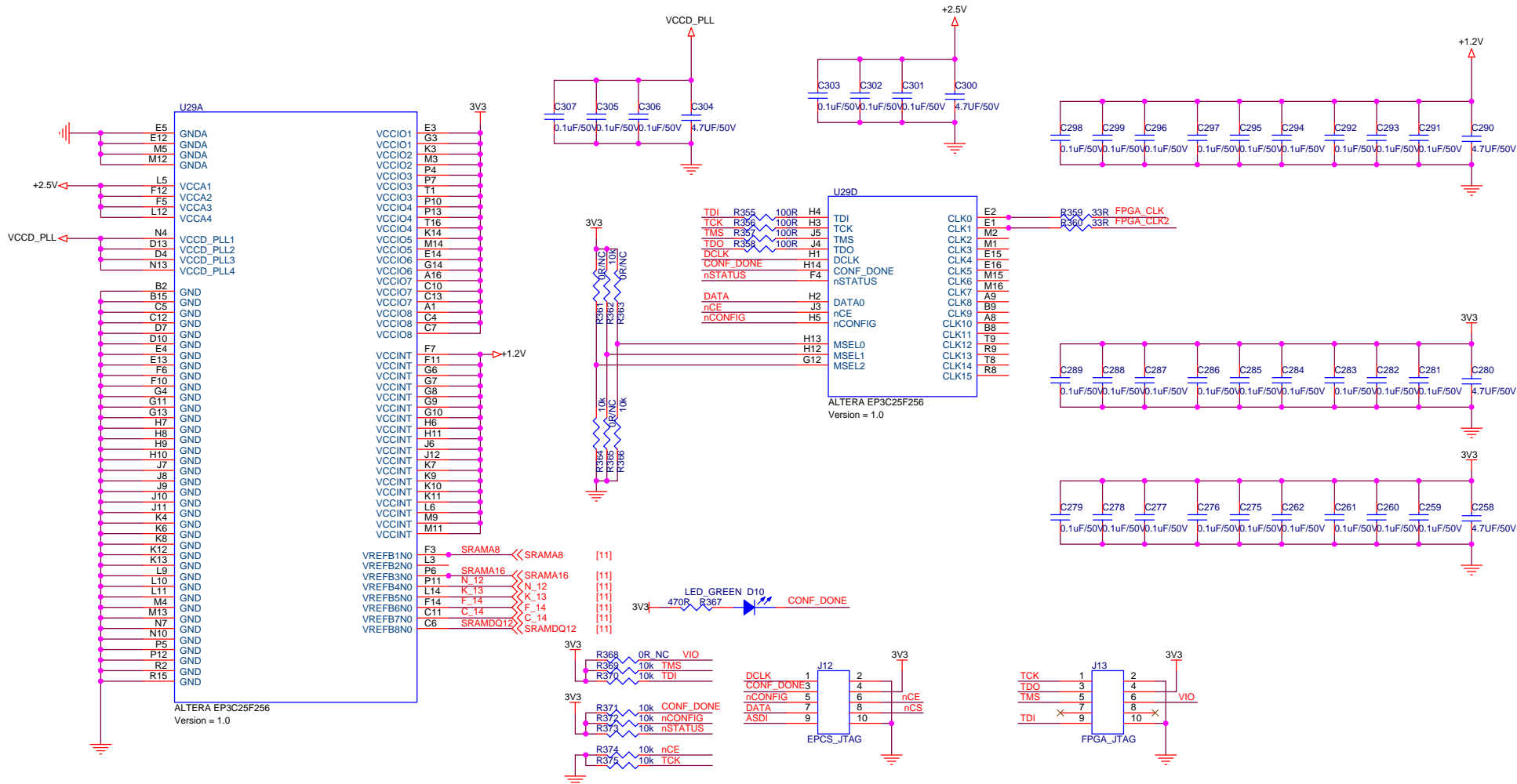

Title		<Title>
Size	Document Number	Rev
A3	<Doc>	<Rev Code>
Date:	Wednesday, March 26, 2014	Sheet 12 of 13

