

Revision History				
Rev	ECN #	Approved Date	Approved by	Notes
B	1	29/11/18	Chethan Kumar Y.B	J17 connector nets modified
B	2	29/11/18	Chethan Kumar Y.B	Mounted R76,R79,R81,R92 resistors
B	3	29/11/18	Chethan Kumar Y.B	Made R43 and R205 as DNP
B	4	29/11/18	Chethan Kumar Y.B	Changed the R120 and C24 part number

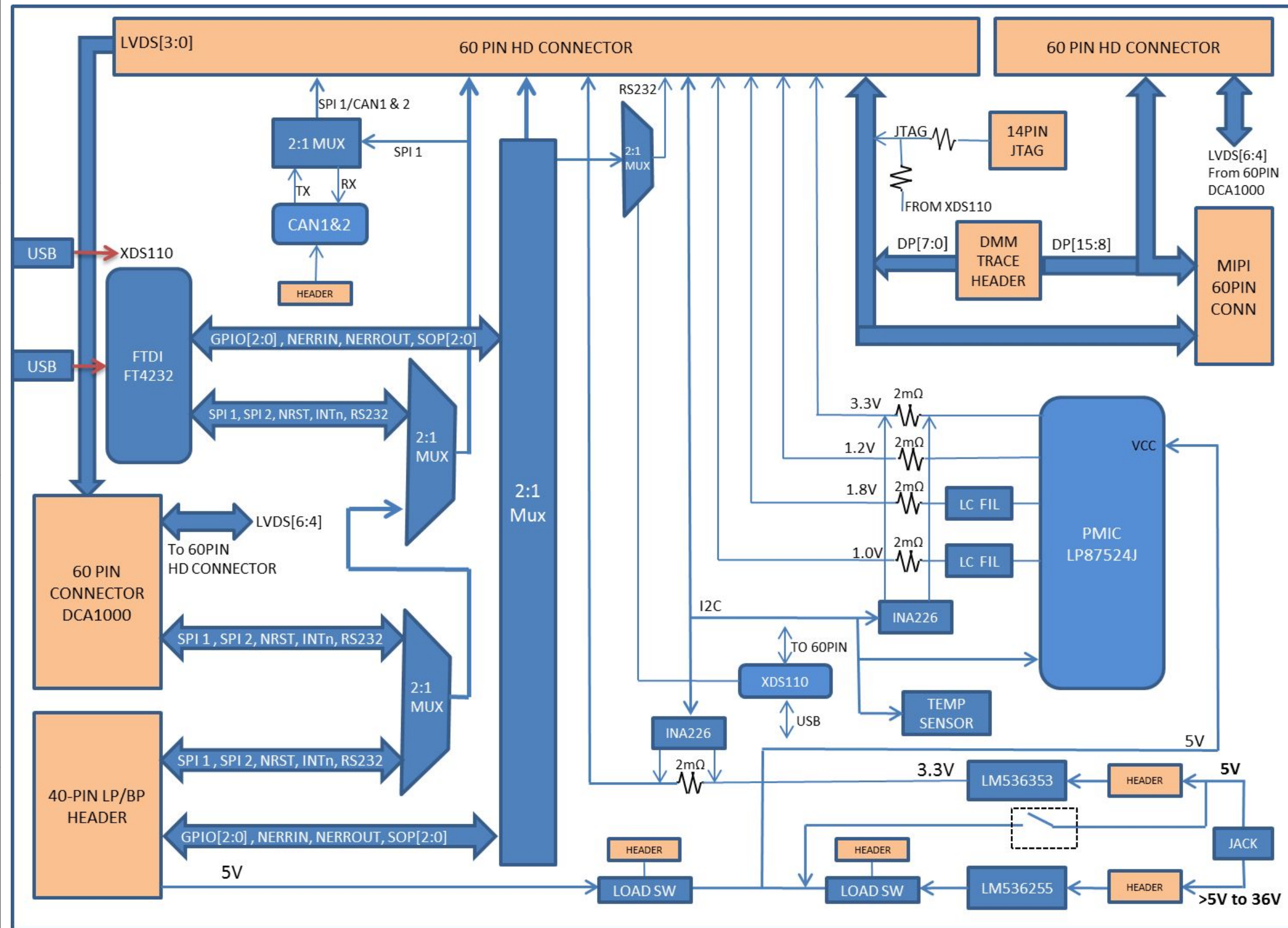

PMIC EN ARCHITECTURE

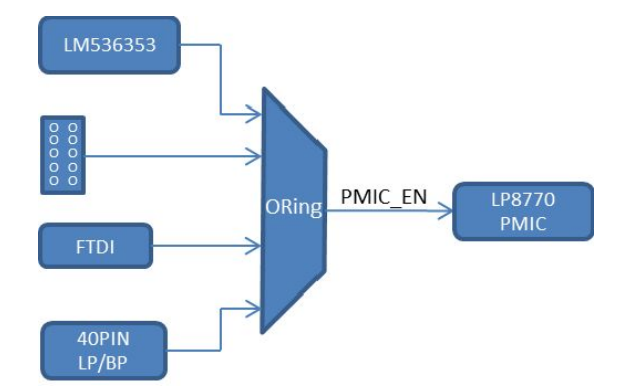

PGOOD ARCHITECTURE

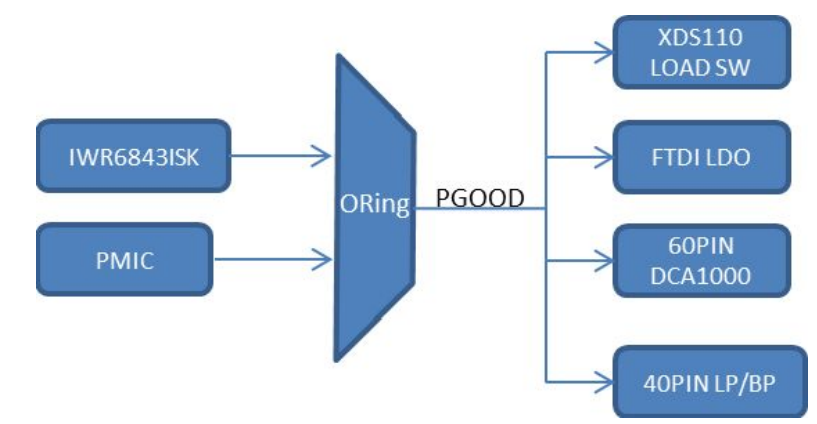

Texas Instruments and/or its licensors do not warrant the accuracy or completeness of this specification or any information contained therein. Texas Instruments and/or its licensors do not warrant that this design will meet the specifications, will be suitable for your application or fit for any particular purpose, or will operate in an implementation. Texas Instruments and/or its licensors do not warrant that the design is production worthy. You should completely validate and test your design implementation to confirm the system functionality for your application.

Orderable: MMWAVEICBOOST	Designed for: Public Release	Mod. Date: 11/29/2018
TID #: N/A	Project Title: MMWAVEICBOOST	
Number: PROC074	Rev: B	Sheet Title:
SVN Rev: Not in version control	Assembly Variant: 001	Sheet: 1 of 22
Drawn By:	File: PROC074B_Block diagram.SchDoc	Size: B
Engineer: Chethan Kumar Y.B	Contact: http://www.ti.com/support	



TABLE OF CONTENTS

SHEET NO.	SHEET NAME
1	Block diagram
2	Table of Contents
3	Muxing_Block_diagram
4	Pwr_RST_LEDs
5	Power_Input_REG
6	Current Sensors
7	LP8752J_PMIC
8	LP Connector
9	BP_LP_RNR_Options
10	HD_Conn_JTAG_HDR
11	XDS110 Interface_1A
12	XDS110 Interface_1B
13	CAN & VPP_Supply
14	SOP selection
15	Tempsensor
16	FTDI_Interface
17	FTDI_Interface_Power
18	CAN Interface_LEDs
19	Analog_Mux_1A
20	Analog_Mux_1B
21	HD_connector_DCA
22	Hardware

MUX SETTINGS

Switch Refdes	Default position	Position for STAND ALONE mode*	Position for DCA1000 mode	Position for 40Pin LP/BP
S1	OFF (SPI-1)	OFF	OFF	OFF
S2	ON (40pin)	Default position	Default position	ON
S3	ON (FTDI)	ON	Default position	OFF
S4	ON (FTDI/40pin/J16)	ON	OFF	ON
S5 ¹	ON (XDS110)	Default position	Default position	Default position
S6	ON (FTDI)	ON	OFF	OFF
S7	ON (FTDI)	ON	OFF	OFF
S8	OFF (60pin)	Default position	OFF	ON
S9	OFF (60pin)	Default position	OFF	ON
S10	ON (FTDI)	ON	Default position	OFF
S11	ON (FTDI)	ON	Default position	OFF
S12	ON (XDS110)	Default position	Default position	Default position

Table 1 : Switch settings for different sources

*Standalone mode means the combination of Starter kit and MMWAVEICBOOST

(1)S5 has RS232 connections from 40pin/FTDI/60pin/XDS110. Default position will be XDS110.

I2C DEVICES

S.No	DESCRIPTION	I2C ADDRESS
1	PMIC	110 0000
2	CURRENT SENSOR 3.3V	100 0010
3	CURRENT SENSOR 3.3V (PMIC)	100 0011
4	CURRENT SENSOR 1.8V	100 0110
5	CURRENT SENSOR 1.2V	100 0111
6	CURRENT SENSOR 1.0V	100 1100
7	TEMPERATURE SENSOR1	100 1001
8	TEMPERATURE SENSOR2	100 1000

MUXING BLOCK DIAGRAM

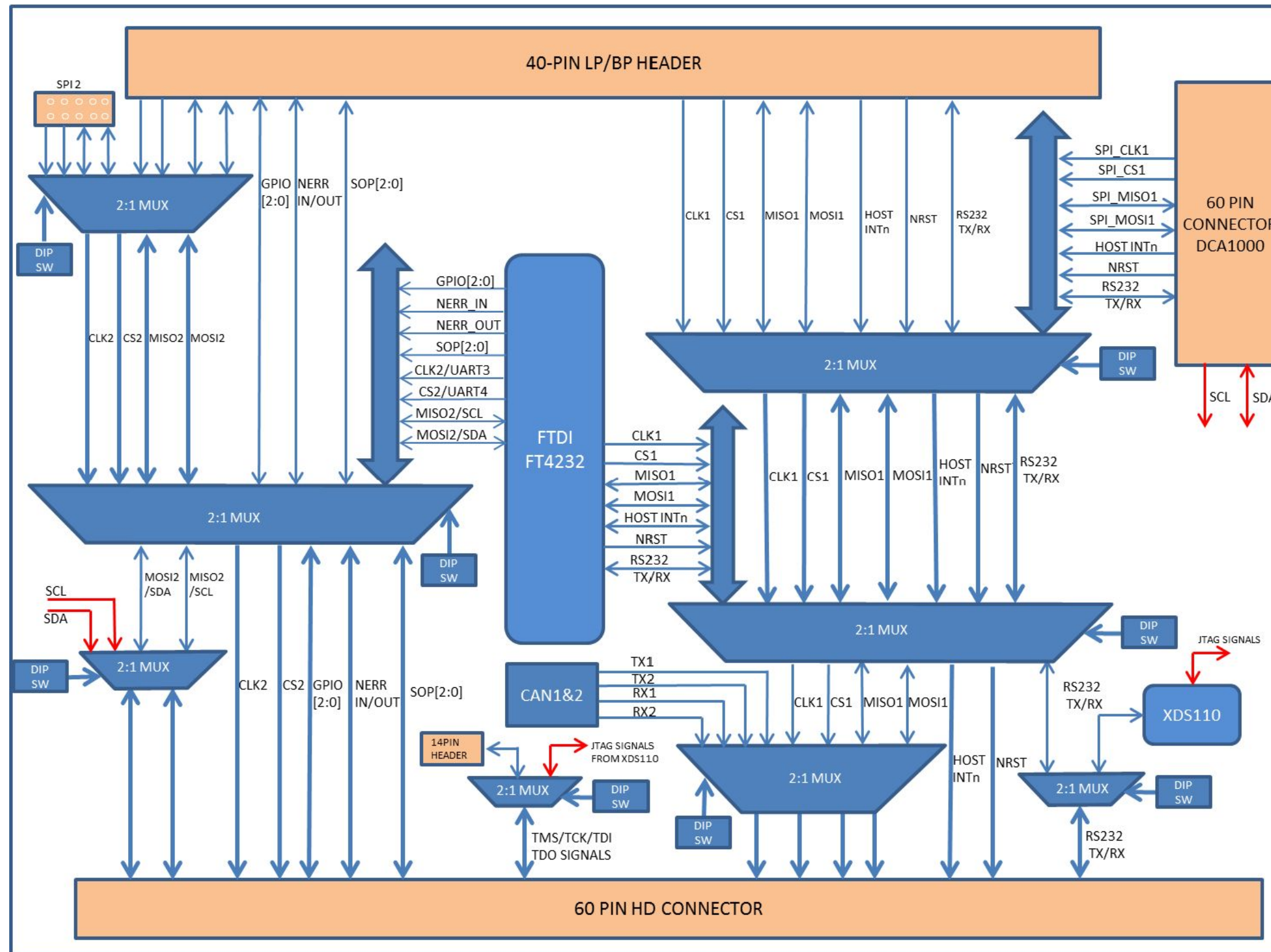

Texas Instruments and/or its licensors do not warrant the accuracy or completeness of this specification or any information contained therein. Texas Instruments and/or its licensors do not warrant that this design will meet the specifications, will be suitable for your application or fit for any particular purpose, or will operate in an implementation. Texas Instruments and/or its licensors do not warrant that the design is production worthy. You should completely validate and test your design implementation to confirm the system functionality for your application.

Orderable: MMWAVEICBOOST	Designed for: Public Release	Mod. Date: 10/11/2018
TID #: N/A	Project Title: MMWAVEICBOOST	
Number: PROC074	Rev: B	Sheet: 3 of 22
SVN Rev: Not in version control	File: PROC074B_Muxing_Block_Diagram.SchDoc	Size: B
Drawn By: Chethan Kumar Y.B	Contact: http://www.ti.com/support	



POWER SUPPLY CONNECTOR

VOLTAGE RANGE= 5V TO 36V
MAX. CURRENT = 2A

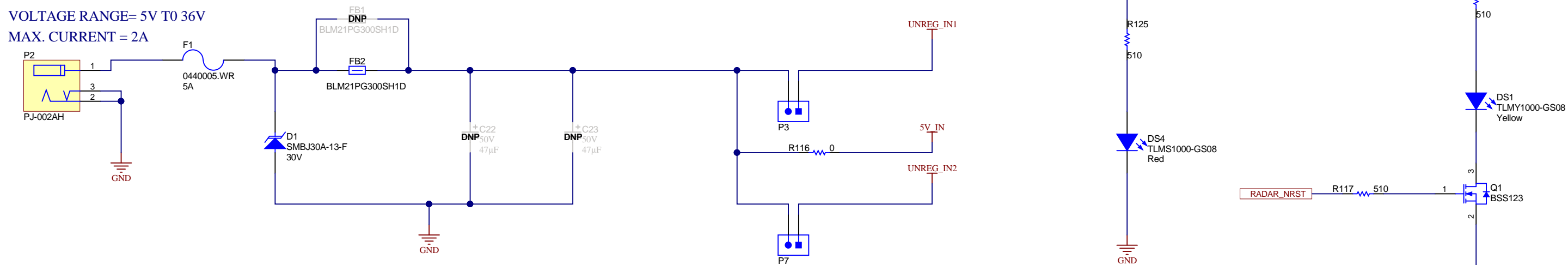

Note : Replace the capacitor(PN:597D476X9050Z2T)in C22 and C23 if the input voltage exceeds 5V

VIN= 5V : Short P3, Mount R116 and do not short P7
VIN= >5V : Short P3,P7 and Remove R116

RESET AND LEDS INDICATION LEDS

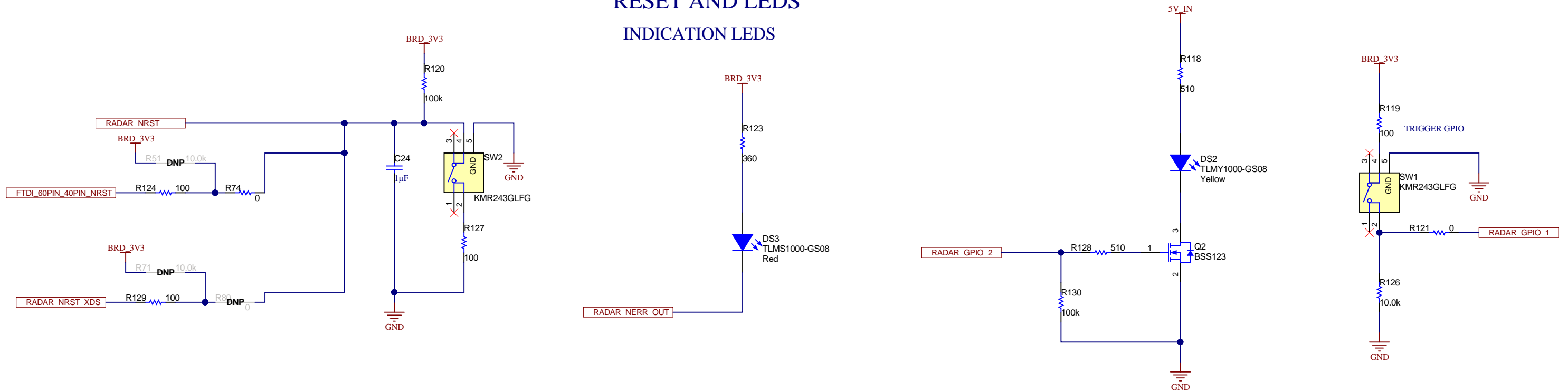

Texas Instruments and/or its licensors do not warrant the accuracy or completeness of this specification or any information contained therein. Texas Instruments and/or its licensors do not warrant that this design will meet the specifications, will be suitable for your application or fit for any particular purpose, or will operate in an implementation. Texas Instruments and/or its licensors do not warrant that the design is production worthy. You should completely validate and test your design implementation to confirm the system functionality for your application.

Orderable: MMWAVEICBOOST	Designed for: Public Release	Mod. Date: 5/2/2019
TID #: N/A	Project Title: MMWAVEICBOOST	
Number: PROC074	Rev: B	Sheet Title:
SVN Rev: Not in version control	Assembly Variant: 001	Sheet: 4 of 22
Drawn By:	File: PROC074B_PWR_RST_LEDs_SchDoc	Size: B
Engineer: Chethan Kumar Y.B	Contact: http://www.ti.com/support	

POWER SUPPLY INPUT 5V TO 3.3V OUTPUT

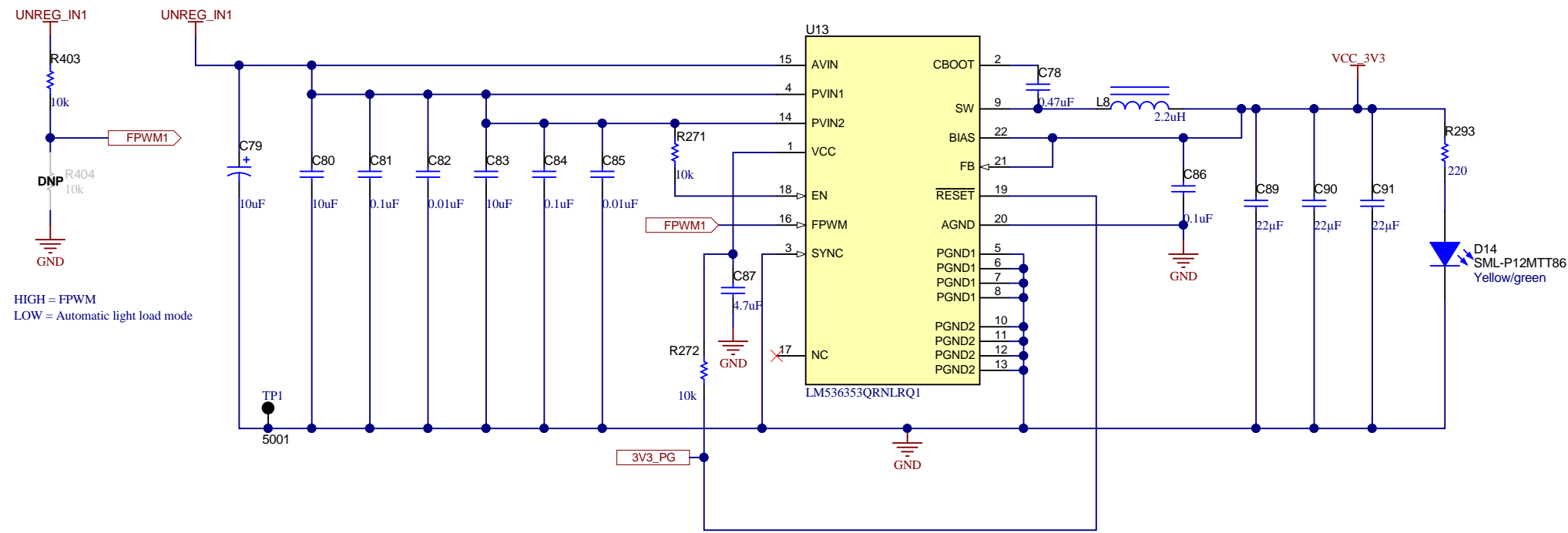

5V SUPPLY FROM JACK

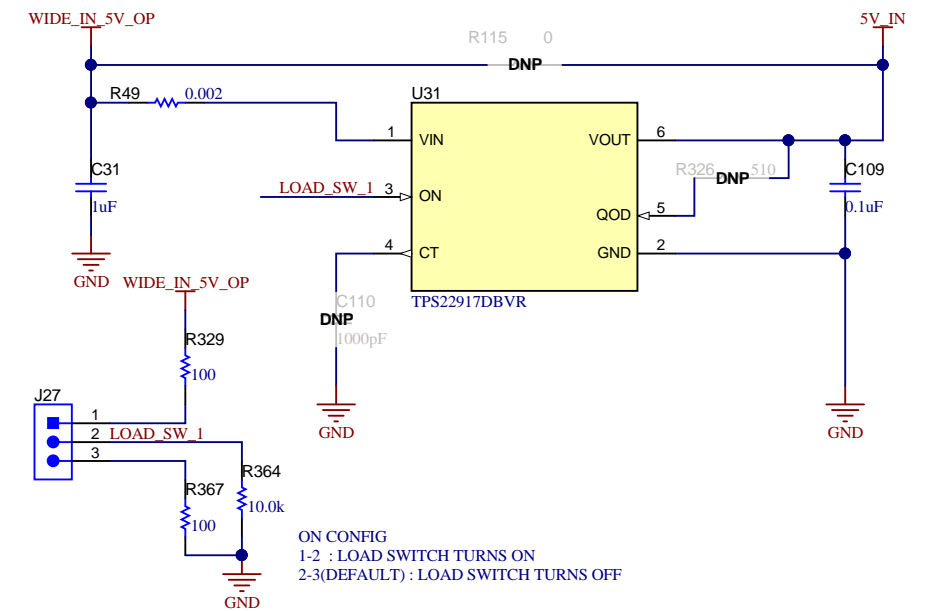

POWER SUPPLY INPUT(6V-36V) TO 5V OUTPUT

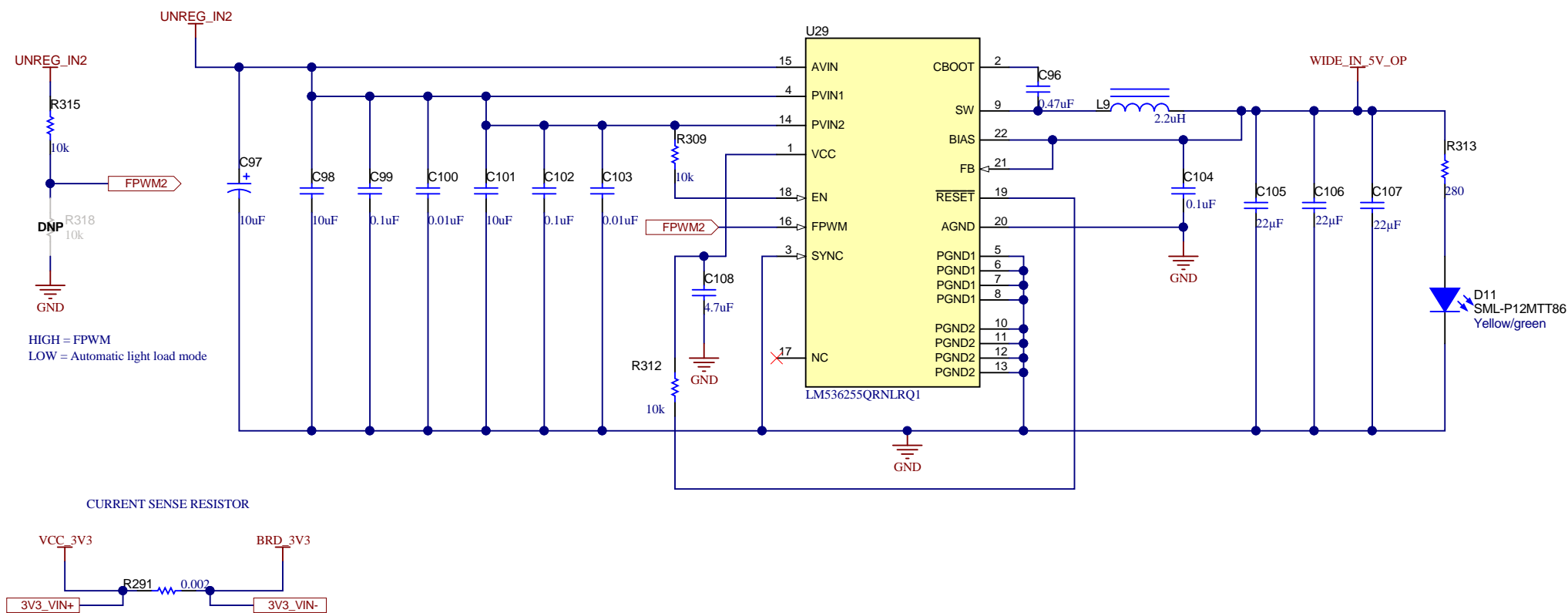

5V SUPPLY FROM THE 40PIN LP/BP CONNECTOR

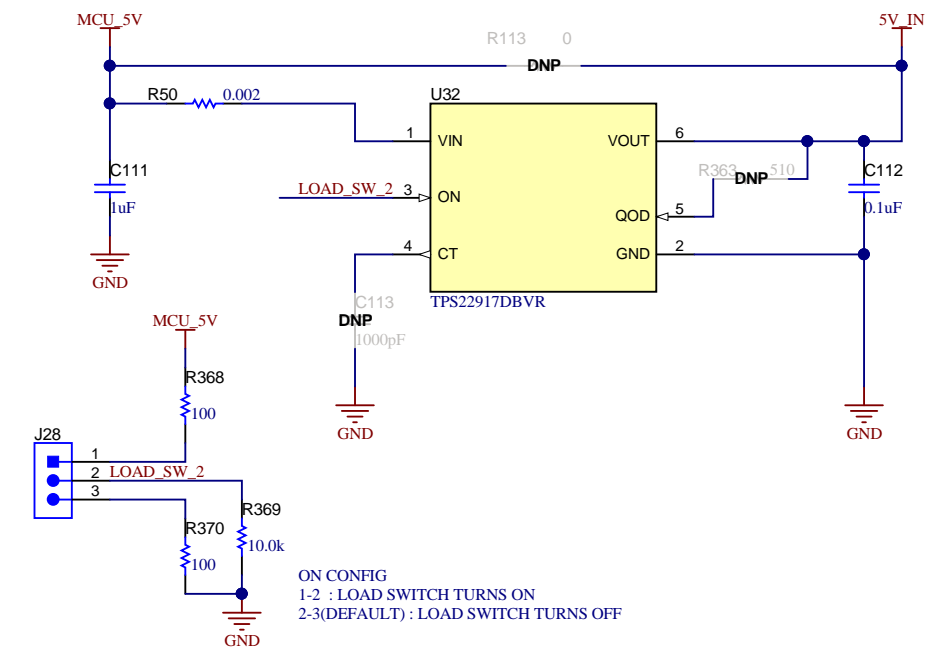

Orderable: MMWAVEICBOOST	Designed for: Public Release	Mod. Date: 5/7/2019
TID #: N/A	Project Title: MMWAVEICBOOST	
Number: PROC074	Rev: B	Sheet Title:
SVN Rev: Not in version control	Assembly Variant: 001	Sheet: 5 of 22
Drawn By:	File: PROC074B_PWR_INPUT_REG.SchDoc	Size: B
Engineer: Chethan Kumar Y.B	Contact: http://www.ti.com/support	

Texas Instruments and/or its licensors do not warrant the accuracy or completeness of this specification or any information contained therein. Texas Instruments and/or its licensors do not warrant that this design will meet the specifications, will be suitable for your application or fit for any particular purpose, or will operate in an implementation. Texas Instruments and/or its licensors do not warrant that the design is production worthy. You should completely validate and test your design implementation to confirm the system functionality for your application.

Current Sensors

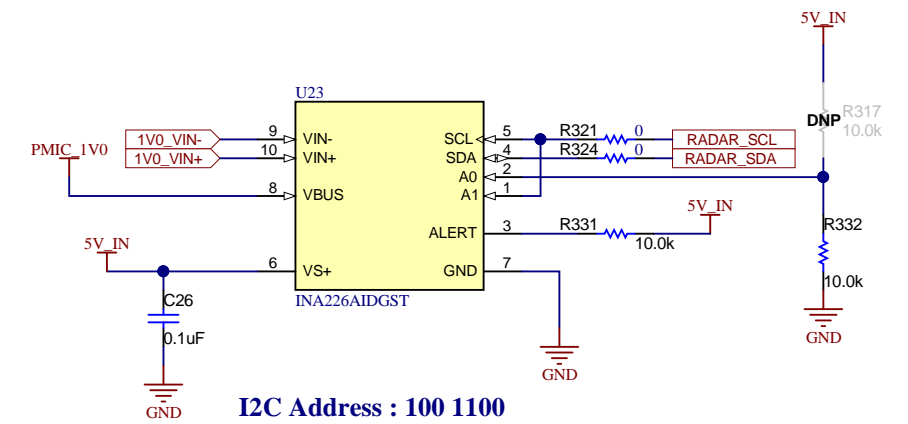
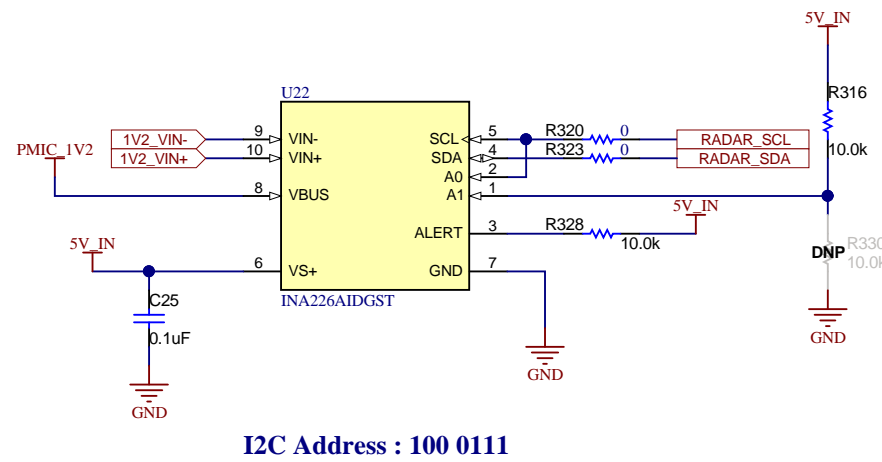
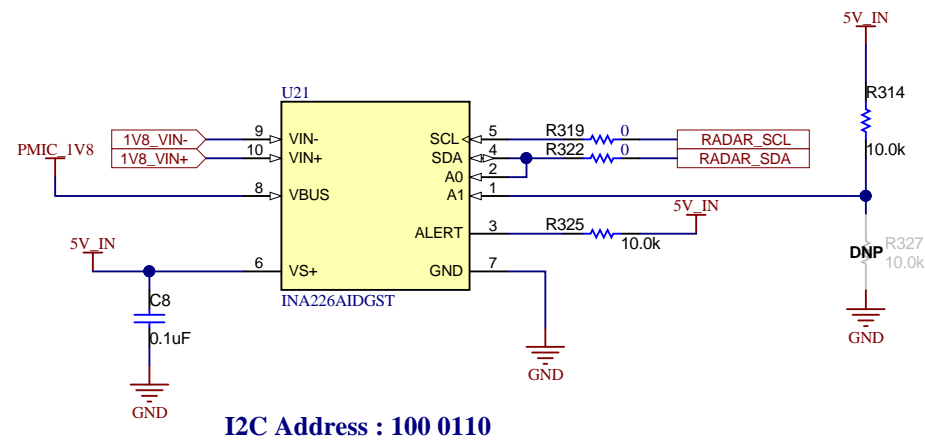
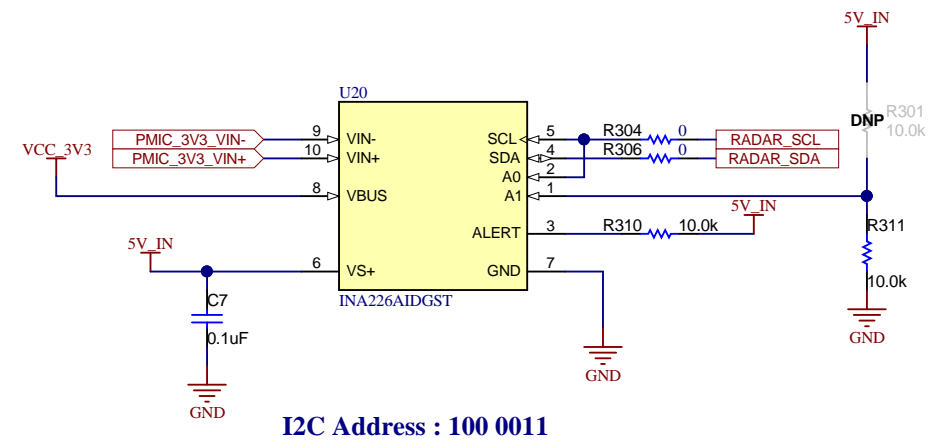
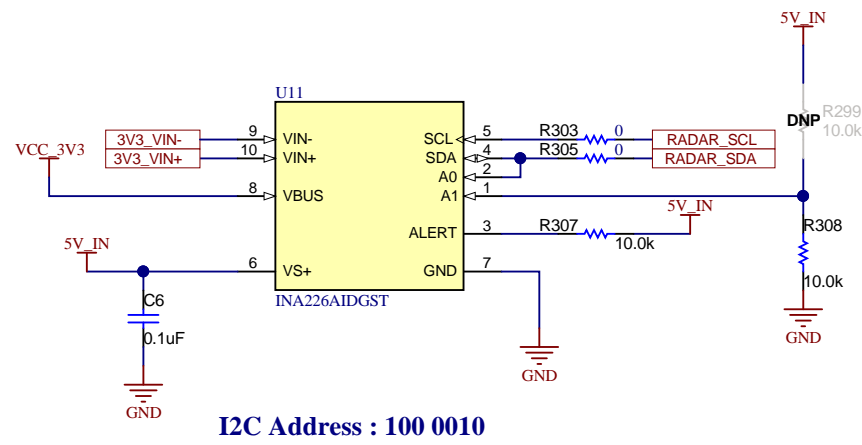

Texas Instruments and/or its licensors do not warrant the accuracy or completeness of this specification or any information contained therein. Texas Instruments and/or its licensors do not warrant that this design will meet the specifications, will be suitable for your application or fit for any particular purpose, or will operate in an implementation. Texas Instruments and/or its licensors do not warrant that the design is production worthy. You should completely validate and test your design implementation to confirm the system functionality for your application.

Orderable: MMWAVEICBOOST	Designed for: Public Release	Mod. Date: 10/11/2018
TID #: N/A	Project Title: MMWAVEICBOOST	
Number: PROC074	Rev: B	Sheet Title:
SVN Rev: Not in version control	Assembly Variant: 001	Sheet: 6 of 22
Drawn By: Chethan Kumar Y.B	File: PROC074B_Current_Sensors.SchDoc	Size: B
Engineer: Chethan Kumar Y.B	Contact: http://www.ti.com/support	

PMIC (3.3V, 1.2V, 1.8V, 1.0V OUTPUTS)

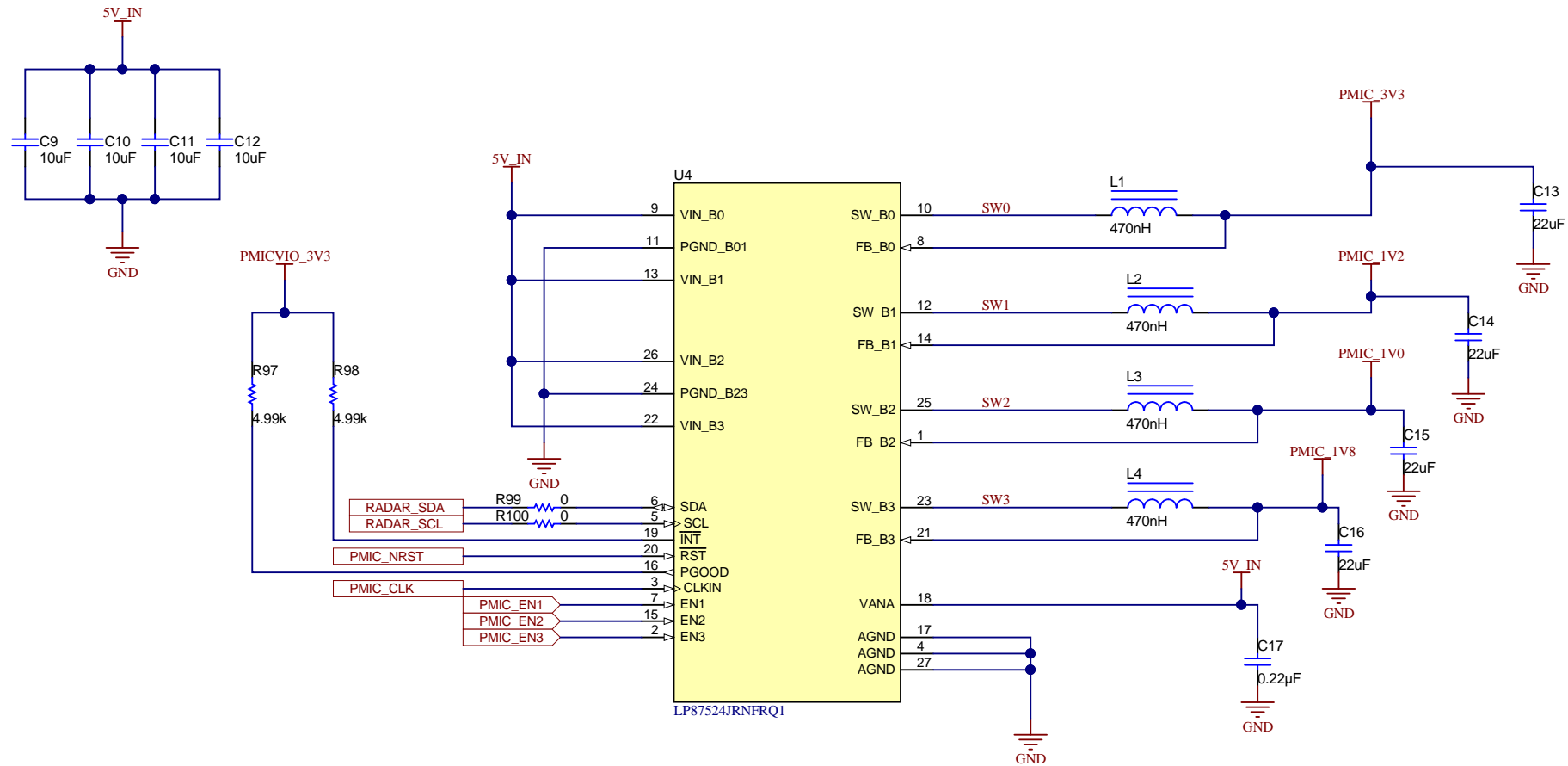

CURRENT SENSE RESISTORS

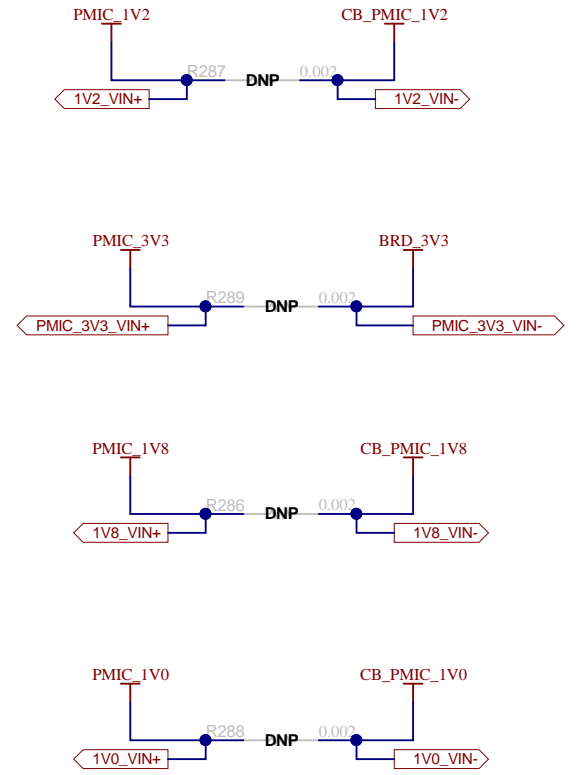

SNUBBER ON SWITCHING NODES

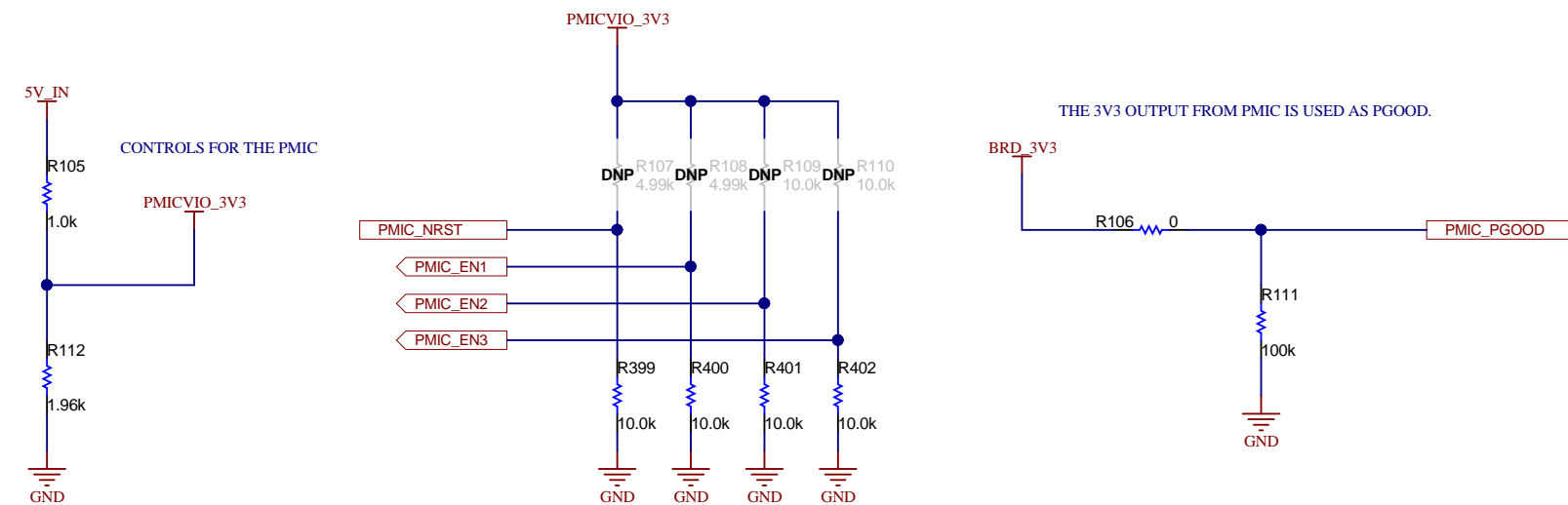
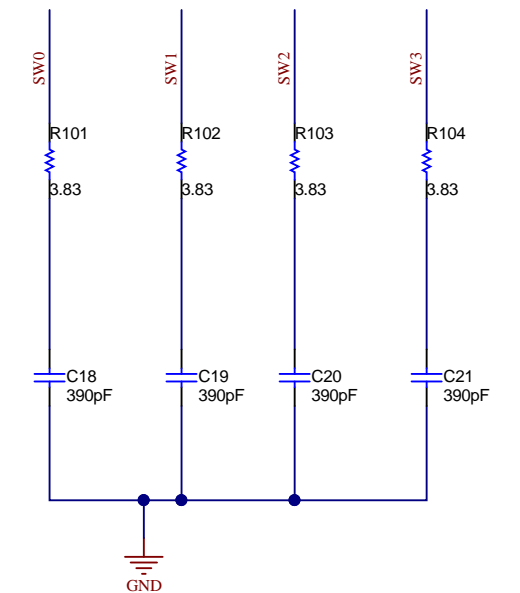

Texas Instruments and/or its licensors do not warrant the accuracy or completeness of this specification or any information contained therein. Texas Instruments and/or its licensors do not warrant that this design will meet the specifications, will be suitable for your application or fit for any particular purpose, or will operate in an implementation. Texas Instruments and/or its licensors do not warrant that the design is production worthy. You should completely validate and test your design implementation to confirm the system functionality for your application.

Orderable: MMWAVEICBOOST	Designed for: Public Release	Mod. Date: 5/7/2019
TID #: N/A	Project Title: MMWAVEICBOOST	
Number: PROC074	Rev: B	Sheet Title:
SVN Rev: Not in version control	Assembly Variant: 001	Sheet: 7 of 22
Drawn By:	File: PROC074B_LP8752J_PMIC.SchDoc	Size: B
Engineer: Chethan Kumar Y.B	Contact: http://www.ti.com/support	



BP/LP CONNECTOR

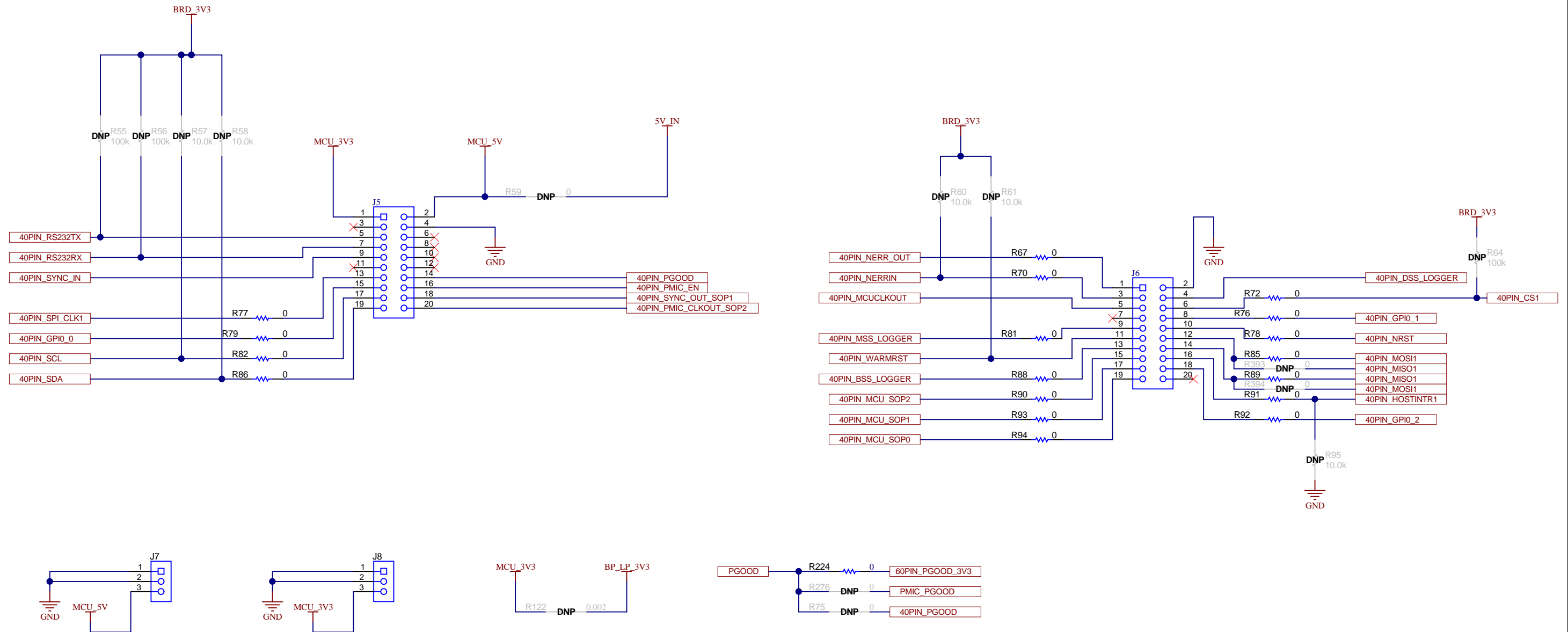

Texas Instruments and/or its licensors do not warrant the accuracy or completeness of this specification or any information contained therein. Texas Instruments and/or its licensors do not warrant that this design will meet the specifications, will be suitable for your application or fit for any particular purpose, or will operate in an implementation. Texas Instruments and/or its licensors do not warrant that the design is production worthy. You should completely validate and test your design implementation to confirm the system functionality for your application.

Orderable: MMWAVEICBOOST	Designed for: Public Release	Mod. Date: 10/11/2018
TID #: N/A	Project Title: MMWAVEICBOOST	
Number: PROC074	Rev: B	Sheet Title:
SVN Rev: Not in version control	Assembly Variant: 001	Sheet: 8 of 22
Drawn By:	File: PROC074B_LP_Connector.SchDoc	Size: B
Engineer: Chethan Kumar Y.B	Contact: http://www.ti.com/support	

BP/LP RNR OPTIONS

RNR FOR MCUCLKOUT

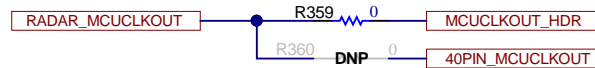

RNR FOR SYNC IN

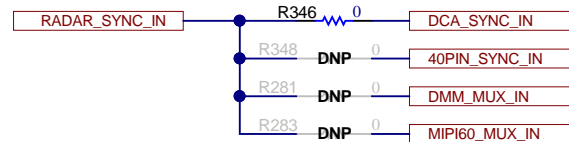

RNR FOR PMIC ENABLE

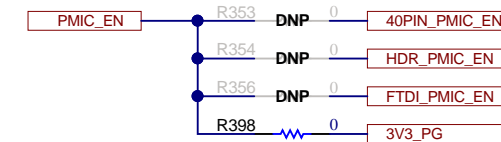

RNR FOR WARMRST

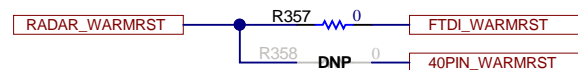

RNR FOR DSS LOGGER



RNR FOR PMIC CLKOUT

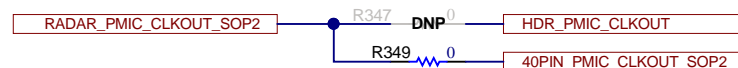

PULL UPS/DOWNS RESISTORS FOR I2C, WARMRST, NERROUT, NERRIN, RS232, SYNC_IN & HOST_INTn

LP/BP SPARE PINS HEADER 1

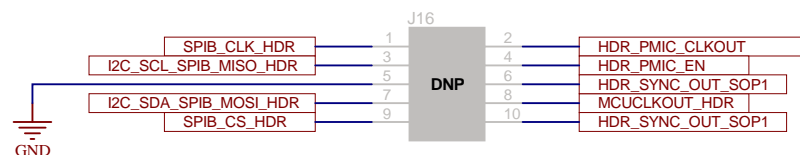

RNR FOR SYNC OUT

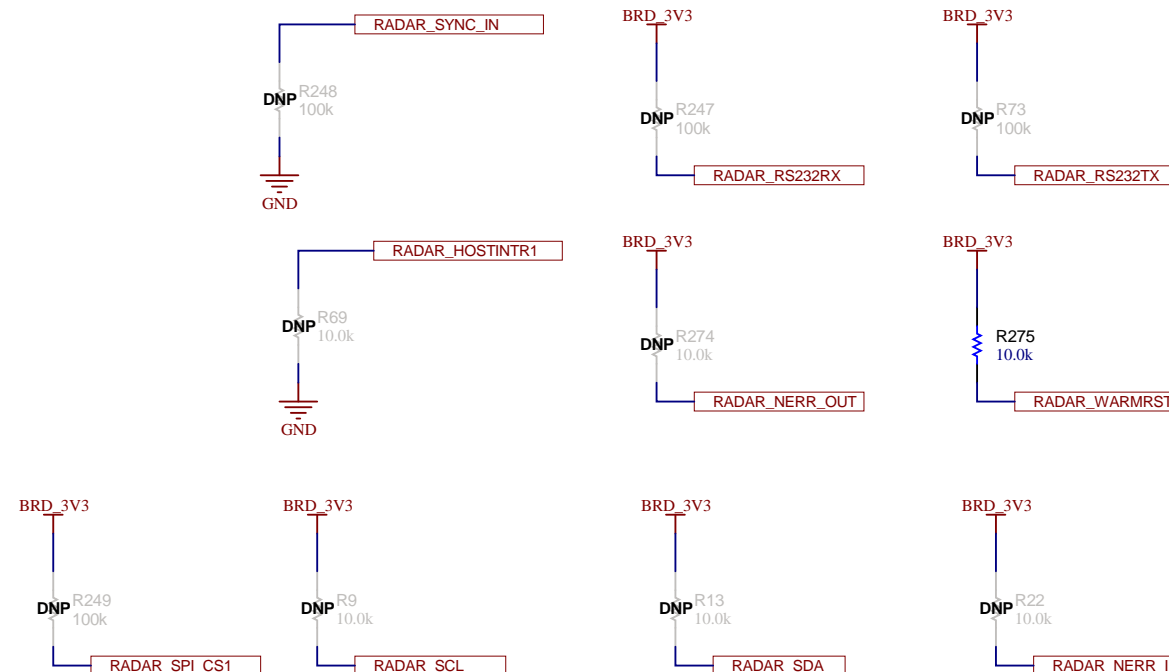
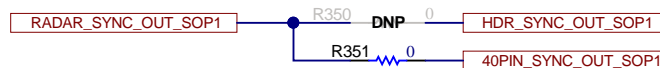

Texas Instruments and/or its licensors do not warrant the accuracy or completeness of this specification or any information contained therein. Texas Instruments and/or its licensors do not warrant that this design will meet the specifications, will be suitable for your application or fit for any particular purpose, or will operate in an implementation. Texas Instruments and/or its licensors do not warrant that the design is production worthy. You should completely validate and test your design implementation to confirm the system functionality for your application.

Orderable: MMWAVEICBOOST	Designed for: Public Release	Mod. Date: 10/11/2018
TID #: N/A	Project Title: MMWAVEICBOOST	
Number: PROC074	Rev: B	Sheet Title:
SVN Rev: Not in version control	Assembly Variant: 001	Sheet: 9 of 22
Drawn By:	File: PROC074B_BP_LP_RNR_Options.SchDoc	Size: B
Engineer: Chethan Kumar Y.B	Contact: http://www.ti.com/support	

HD CONNECTOR FOR LVDS AND JTAG

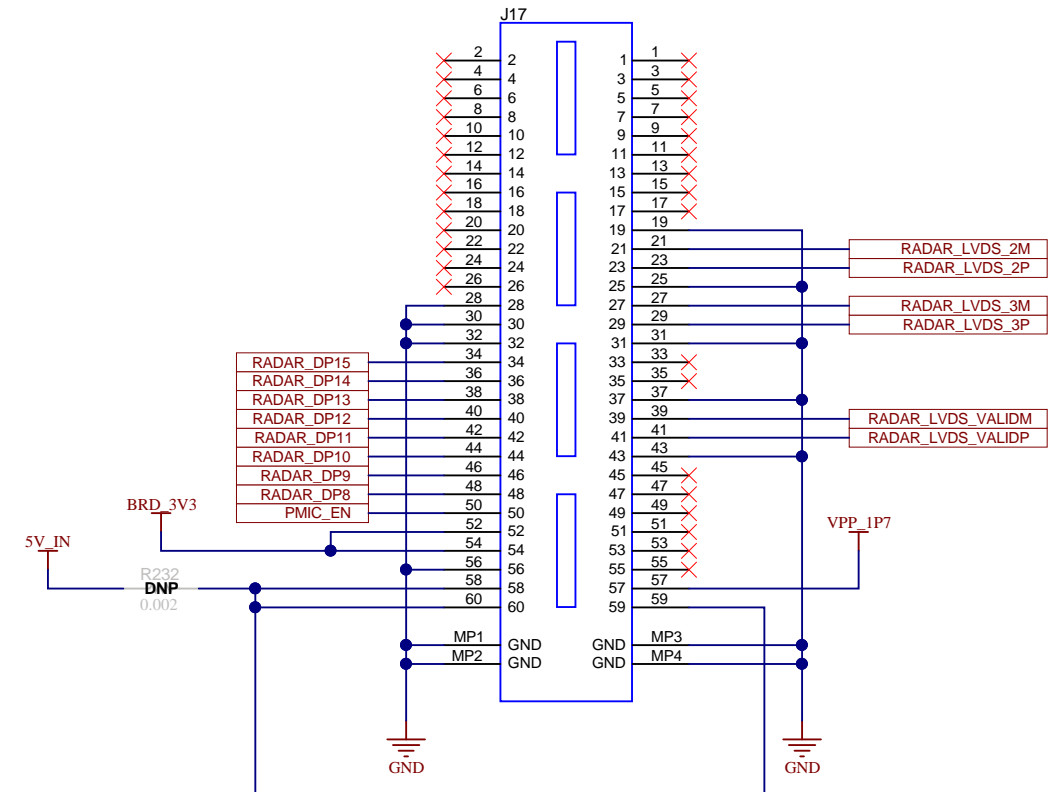
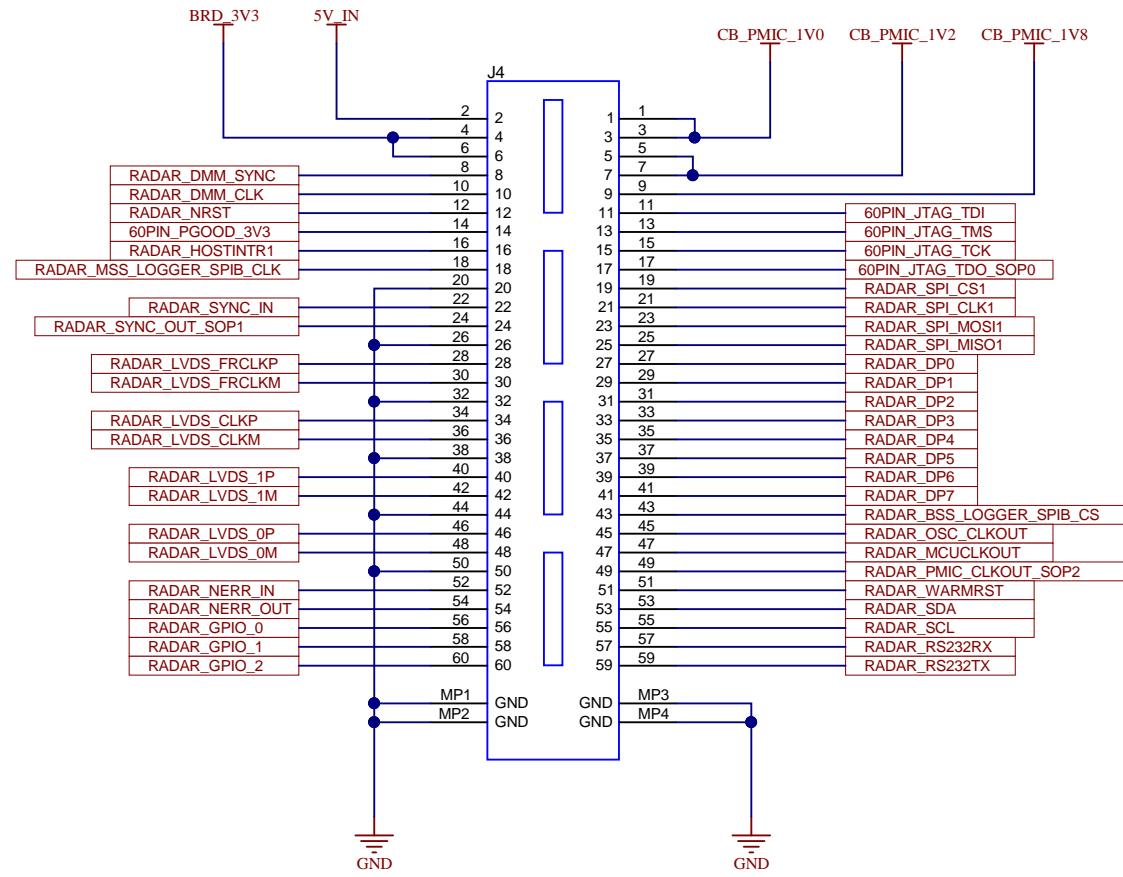

JTAG DEBUG CONNECTOR

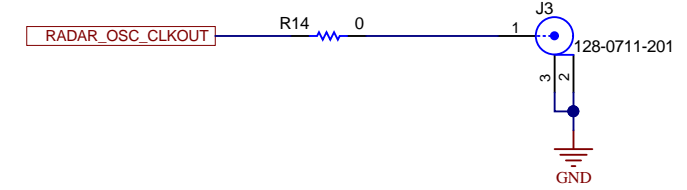
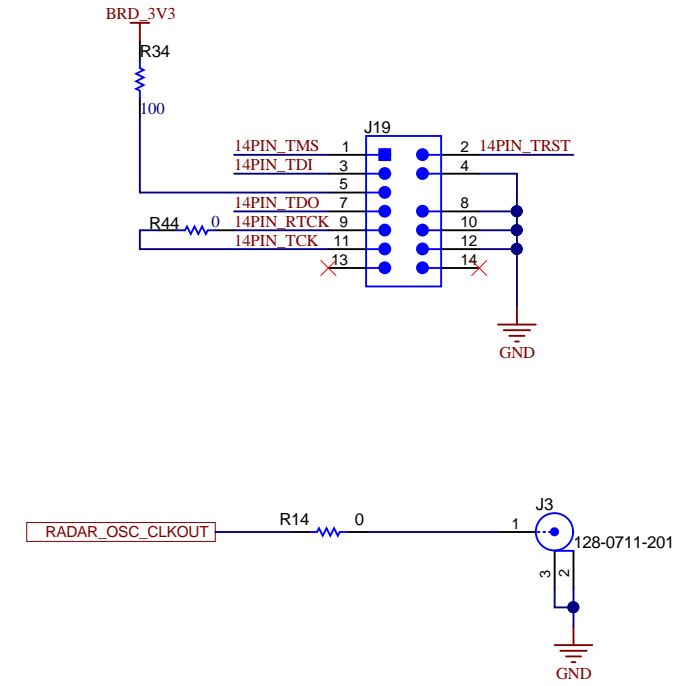

XDS/14PIN JTAG SELECTION

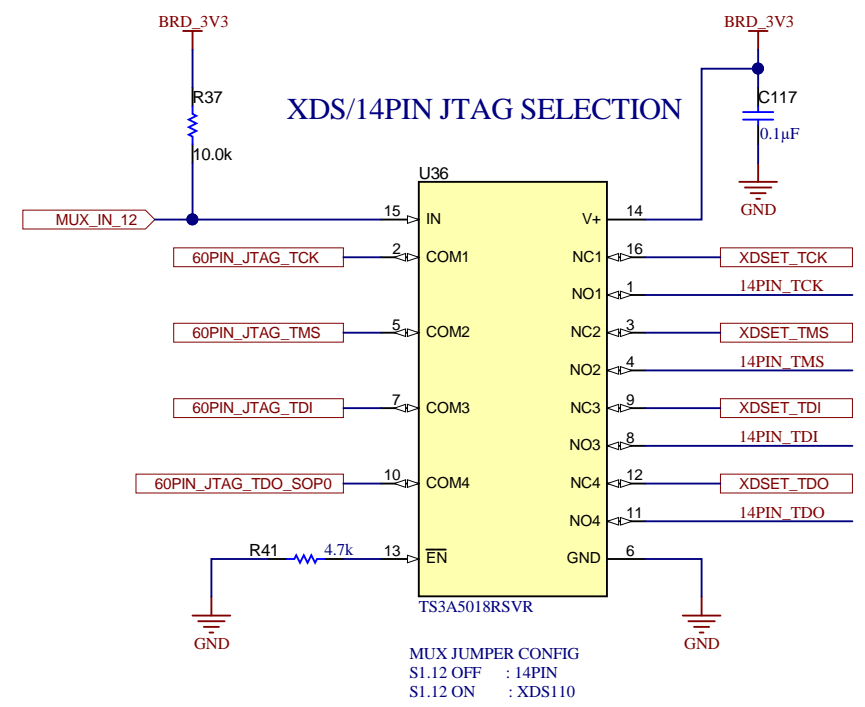

JTAG TRACE DMM INTERFACE HEADER

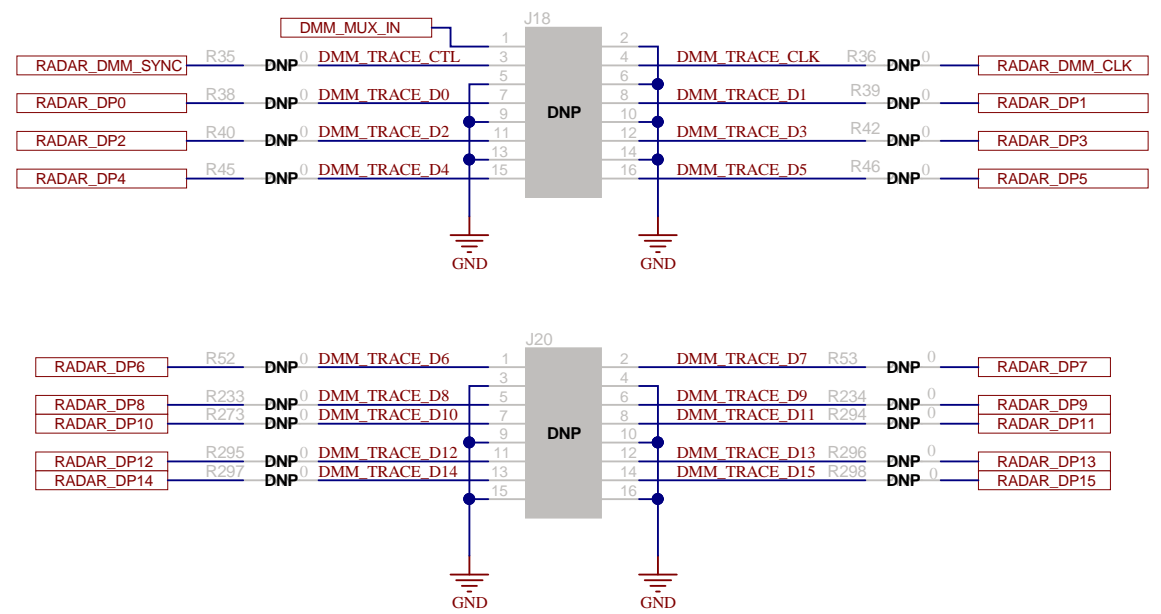

Texas Instruments and/or its licensors do not warrant the accuracy or completeness of this specification or any information contained therein. Texas Instruments and/or its licensors do not warrant that this design will meet the specifications, will be suitable for your application or fit for any particular purpose, or will operate in an implementation. Texas Instruments and/or its licensors do not warrant that the design is production worthy. You should completely validate and test your design implementation to confirm the system functionality for your application.

XDS110(1/2)

Load switch for turning on 3.3V to XDS110

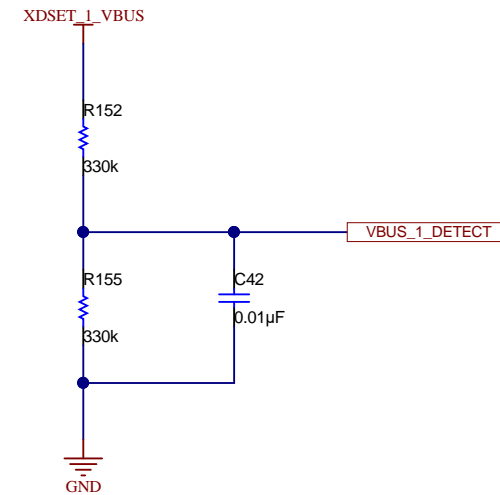
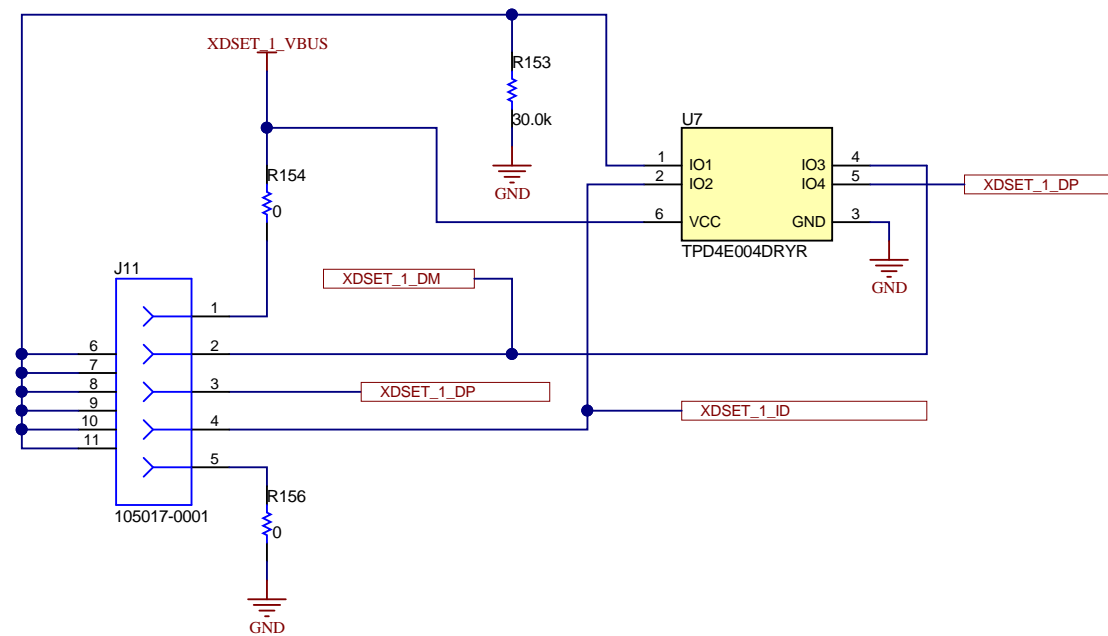
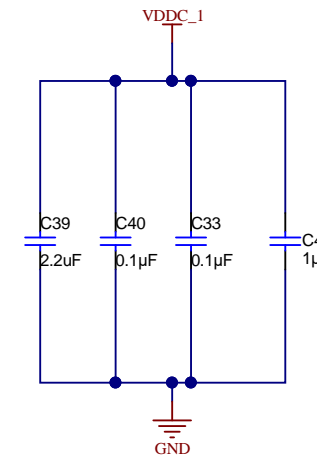
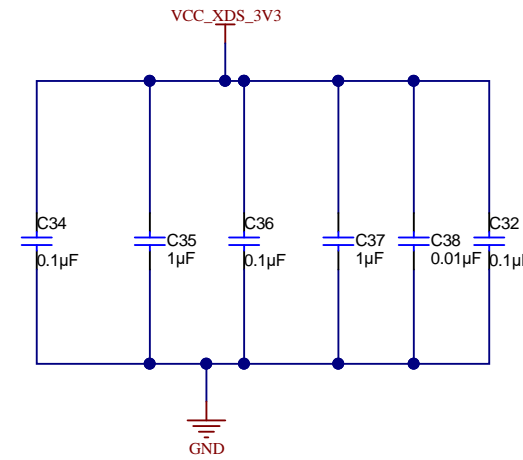
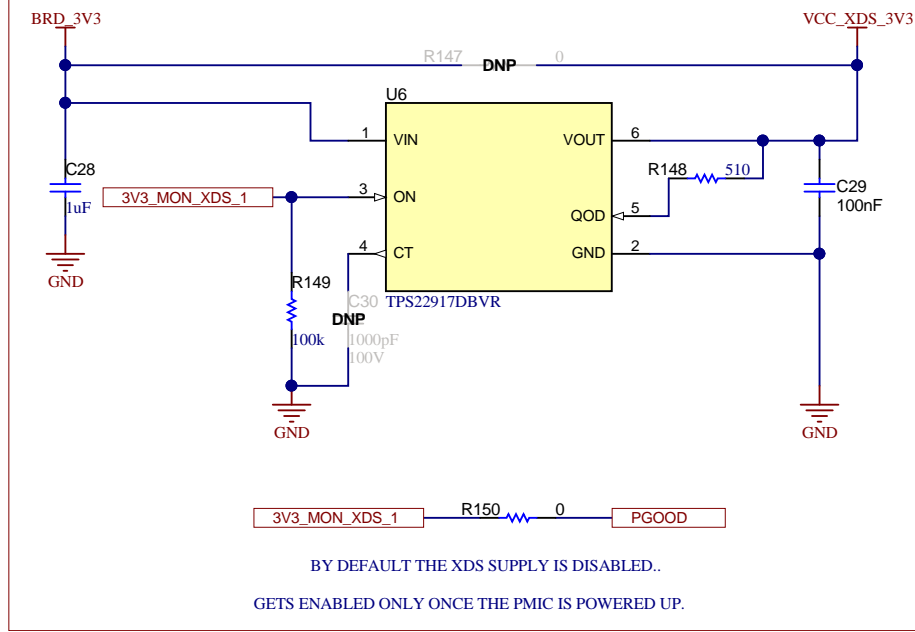

XDS110(2/2)

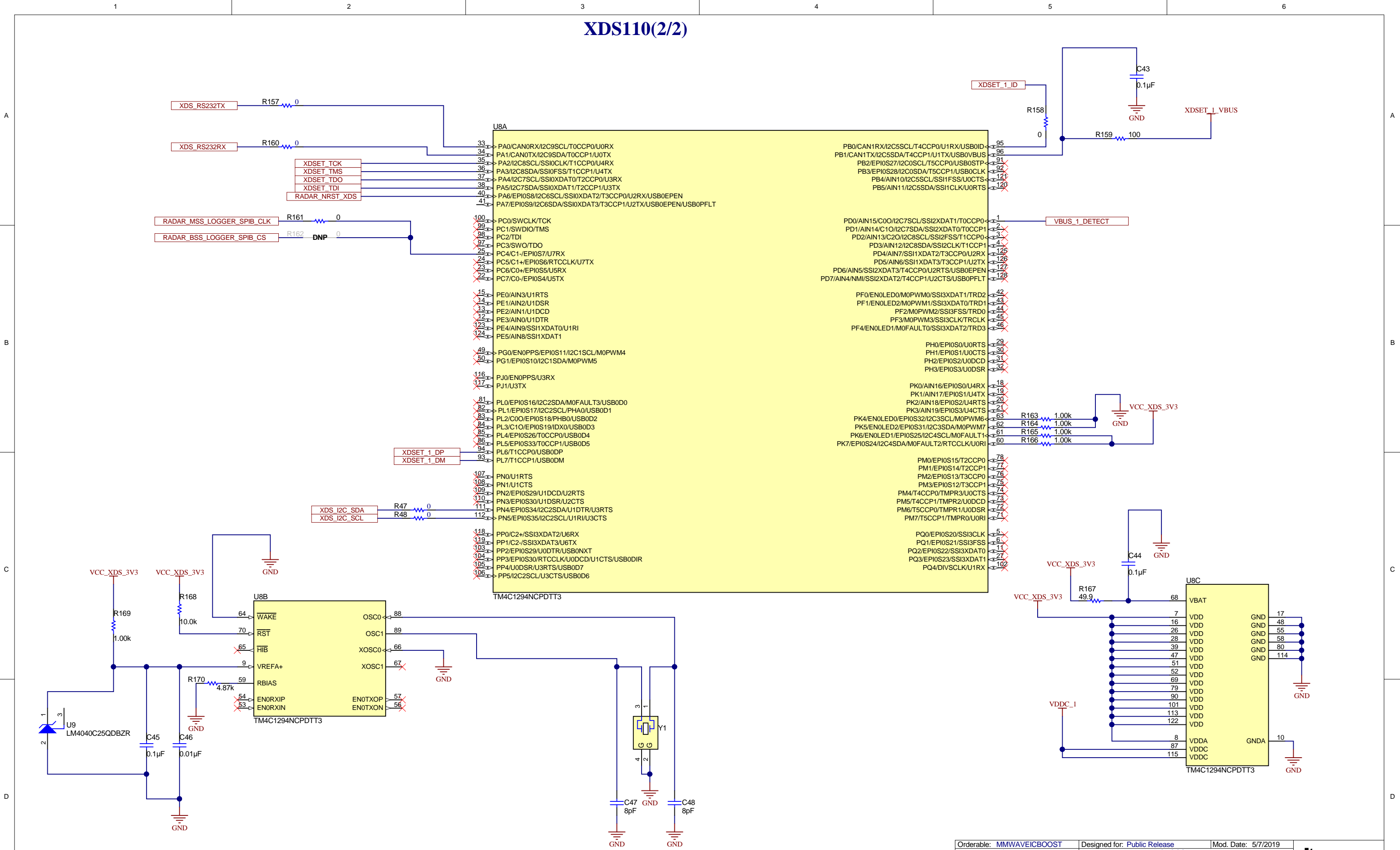

Texas Instruments and/or its licensors do not warrant the accuracy or completeness of this specification or any information contained therein. Texas Instruments and/or its licensors do not warrant that this design will meet the specifications, will be suitable for your application or fit for any particular purpose, or will operate in an implementation. Texas Instruments and/or its licensors do not warrant that the design is production worthy. You should completely validate and test your design implementation to confirm the system functionality for your application.

Orderable: MMWAVEICBOOST	Designed for: Public Release	Mod. Date: 5/7/2019
TID #: N/A	Project Title: MMWAVEICBOOST	
Number: PROC074	Rev: B	Sheet Title:
SVN Rev: Not in version control	Assembly Variant: 001	Sheet: 12 of 22
Drawn By:	File: PROC074B_XDS110_Interface_1B.SchDoc	Size: B
Engineer: Chethan Kumar Y.B	Contact: http://www.ti.com/support	



<http://www.ti.com>

 © Texas Instruments 2018

CAN_FD TRANSCEIVER

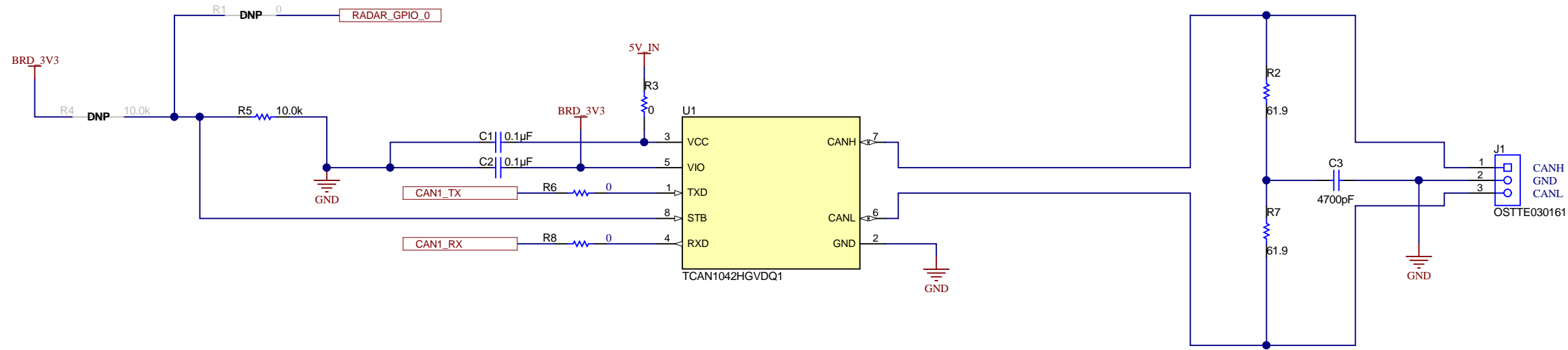

CAN/SPI SELECTION

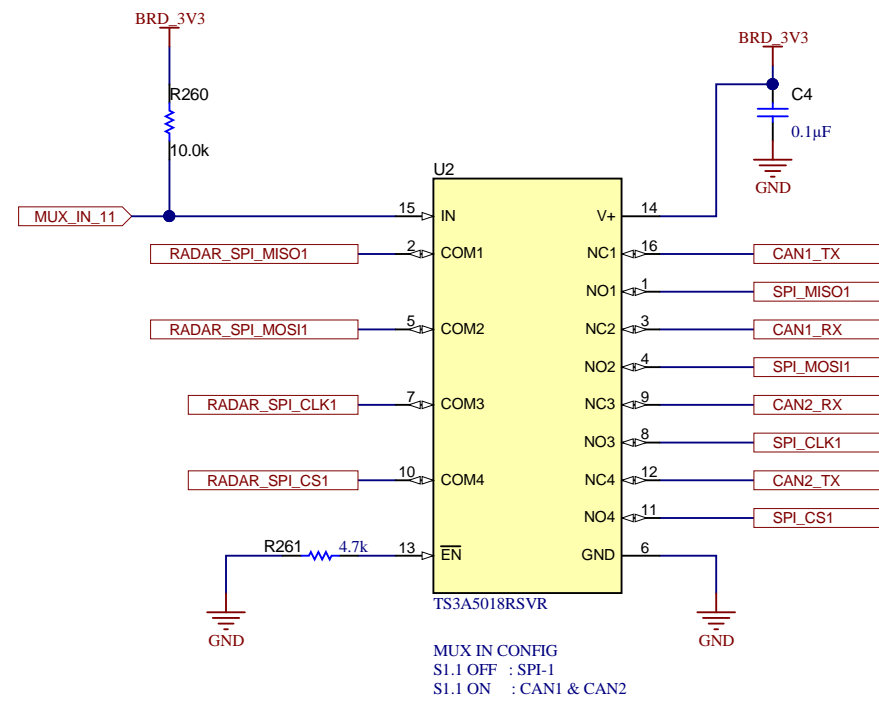

VPP Supply

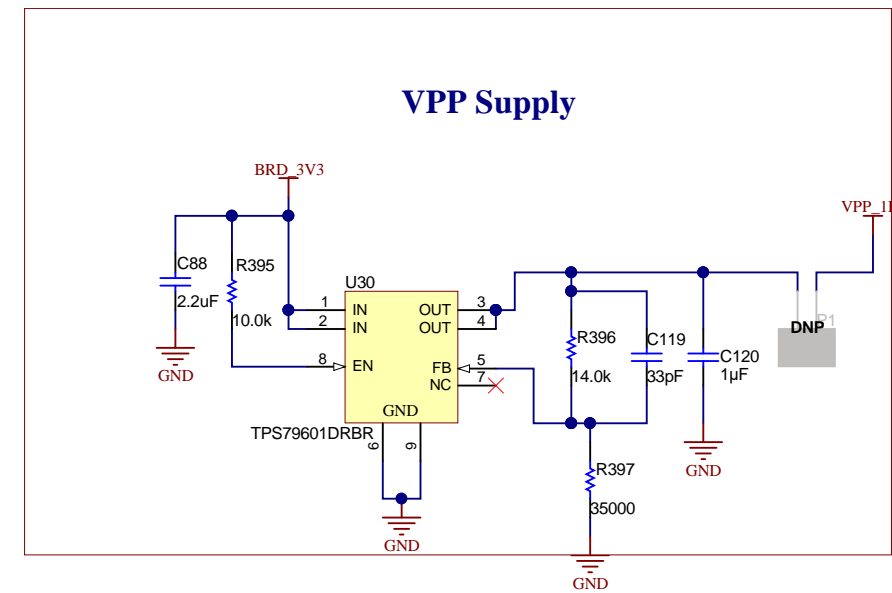

SOP HEADERS

SOP_MODE2 "011" DEV/FLED
 SOP_MODE4 "001" FUNC -> DEFAULT VALUE FOR OUTPUTS
 SOP_MODE5 "101" DEV MANAGEMENT -> FOR FLASHING

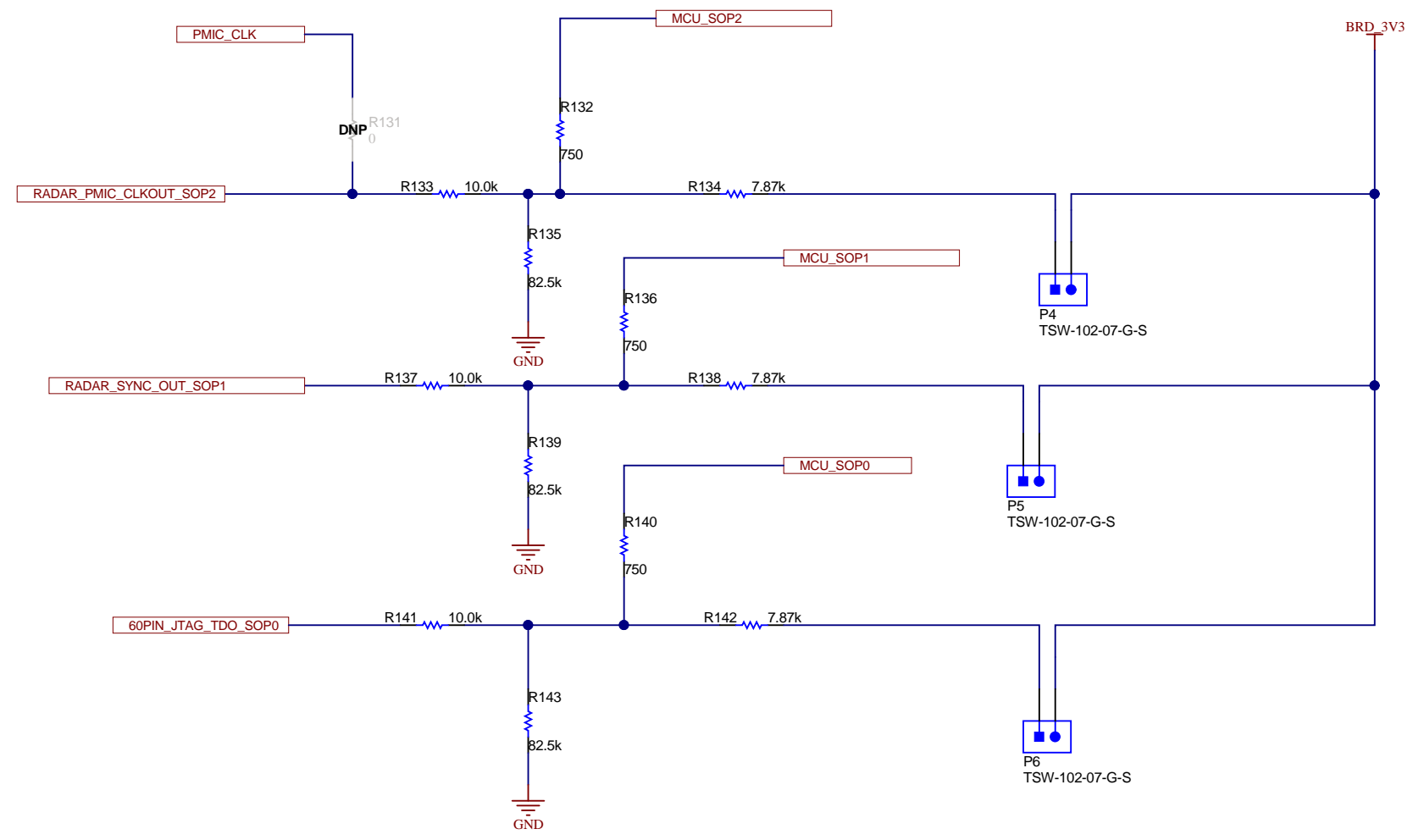

Texas Instruments and/or its licensors do not warrant the accuracy or completeness of this specification or any information contained therein. Texas Instruments and/or its licensors do not warrant that this design will meet the specifications, will be suitable for your application or fit for any particular purpose, or will operate in an implementation. Texas Instruments and/or its licensors do not warrant that the design is production worthy. You should completely validate and test your design implementation to confirm the system functionality for your application.

Orderable: MMWAVEICBOOST	Designed for: Public Release	Mod. Date: 5/2/2019	 http://www.ti.com © Texas Instruments 2018
TID #: N/A	Project Title: MMWAVEICBOOST		
Number: PROC074	Rev: B	Sheet Title:	
SVN Rev: Not in version control	Assembly Variant: 001	Sheet: 14 of 22	
Drawn By:	File: PROC074B_SOP_Selection.SchDoc	Size: B	
Engineer: Chethan Kumar Y.B	Contact: http://www.ti.com/support		

ONBOARD TEMP SENSORS

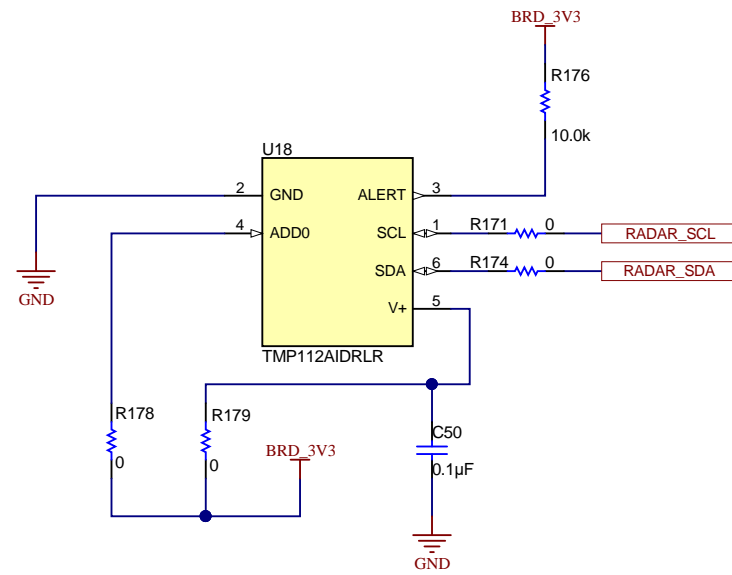

I2C ADDRESS: 100 1001
TEMP SENSOR AWAY FROM PMIC

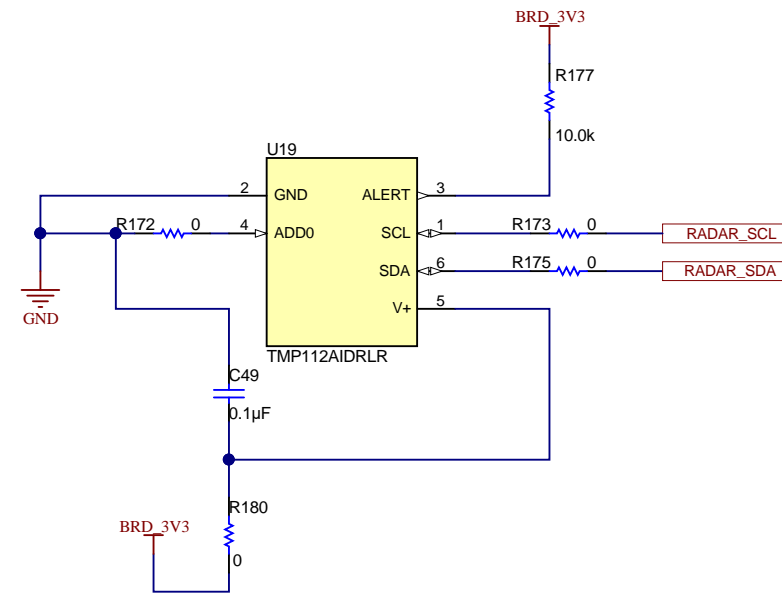

I2C Address : 100 1000
TEMP SENSOR CLOSE TO PMIC

Texas Instruments and/or its licensors do not warrant the accuracy or completeness of this specification or any information contained therein. Texas Instruments and/or its licensors do not warrant that this design will meet the specifications, will be suitable for your application or fit for any particular purpose, or will operate in an implementation. Texas Instruments and/or its licensors do not warrant that the design is production worthy. You should completely validate and test your design implementation to confirm the system functionality for your application.

Orderable: MMWAVEICBOOST	Designed for: Public Release	Mod. Date: 10/11/2018
TID #: N/A	Project Title: MMWAVEICBOOST	
Number: PROC074	Rev: B	Sheet: 15 of 22
SVN Rev: Not in version control	Assembly Variant: 001	Sheet: 15 of 22
Drawn By: Chethan Kumar Y.B	File: PROC074B_Temp_Sensor.SchDoc	Size: B
Engineer: Chethan Kumar Y.B	Contact: http://www.ti.com/support	

FTDI INTERFACE

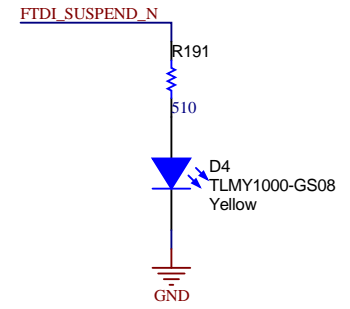
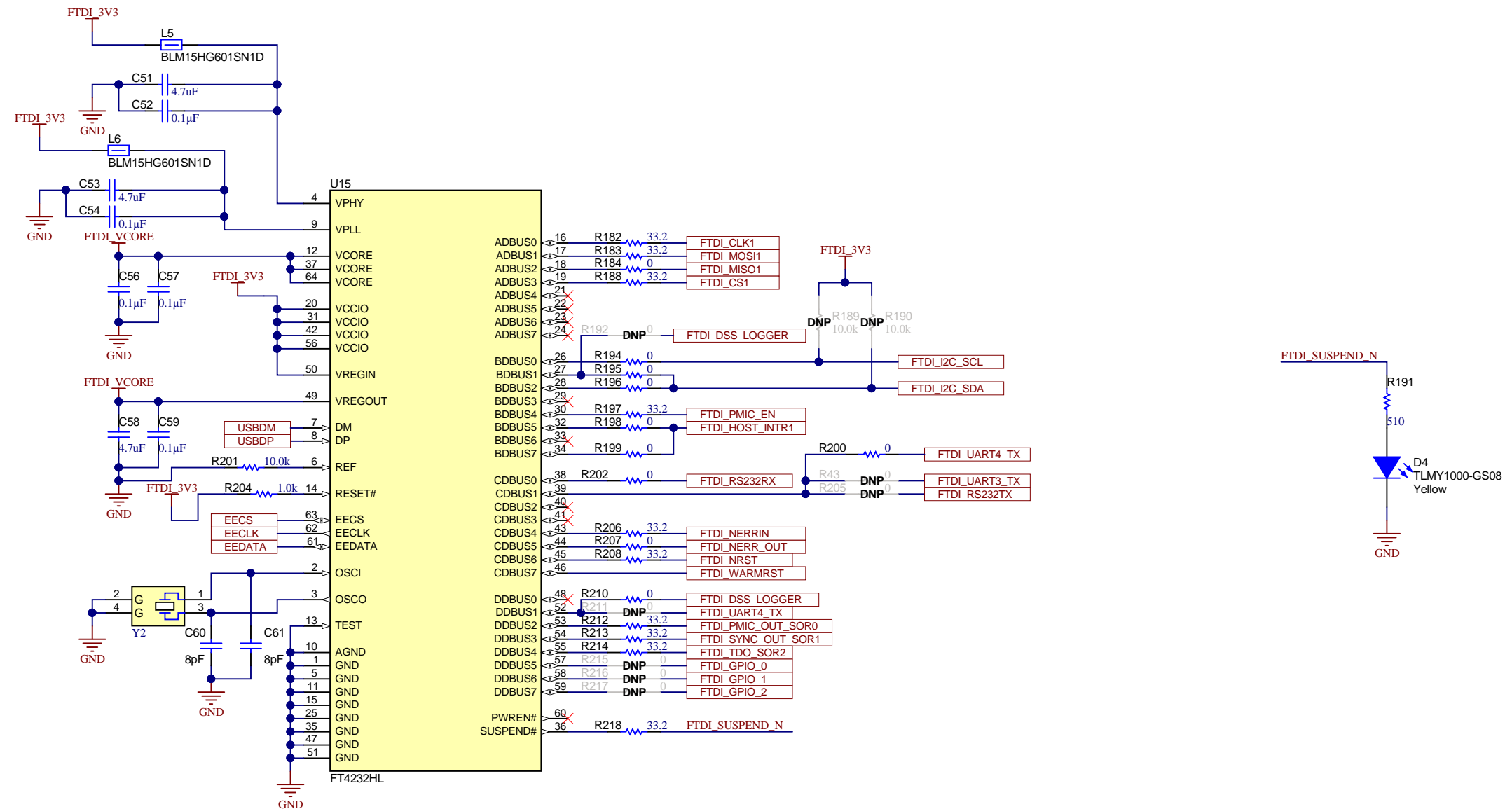

Texas Instruments and/or its licensors do not warrant the accuracy or completeness of this specification or any information contained therein. Texas Instruments and/or its licensors do not warrant that this design will meet the specifications, will be suitable for your application or fit for any particular purpose, or will operate in an implementation. Texas Instruments and/or its licensors do not warrant that the design is production worthy. You should completely validate and test your design implementation to confirm the system functionality for your application.

Orderable: MMWAVEICBOOST	Designed for: Public Release	Mod. Date: 5/7/2019
TID #: N/A	Project Title: MMWAVEICBOOST	
Number: PROC074	Rev: B	Sheet: 16 of 22
SVN Rev: Not in version control	File: PROC074B_FTDI_Interface.SchDoc	Size: B
Drawn By: Chethan Kumar Y.B	Contact: http://www.ti.com/support	



FTDI POWER SECTION

3.3V LDO FOR FTDI

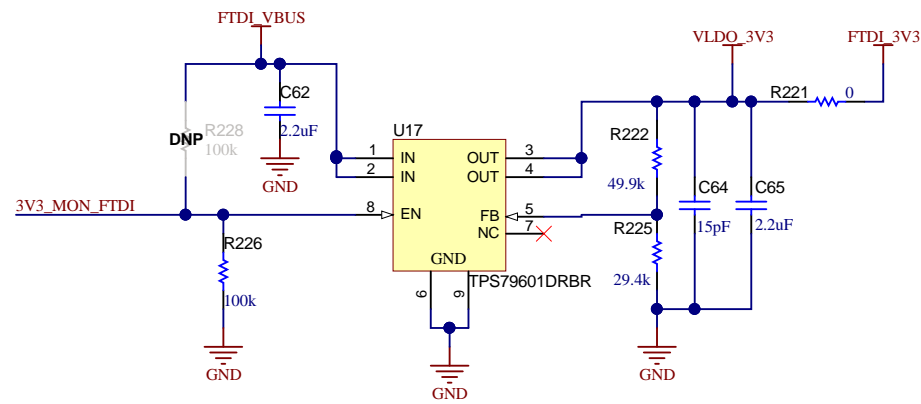

THIS 3.3V LDO WILL TURN ON EITHER FOR IWR6XXX MODULE BOARD OR CARRIER BOARD IS POWERED UP

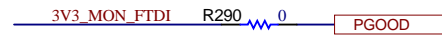
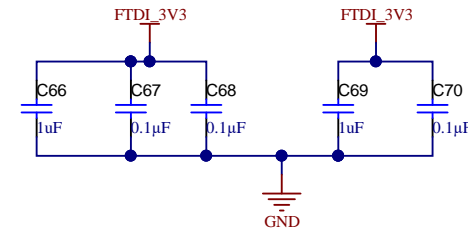

FTDI EEPROM

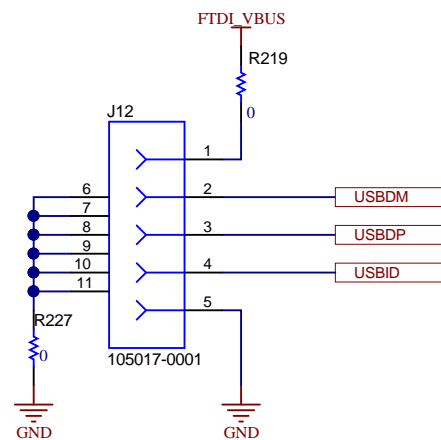
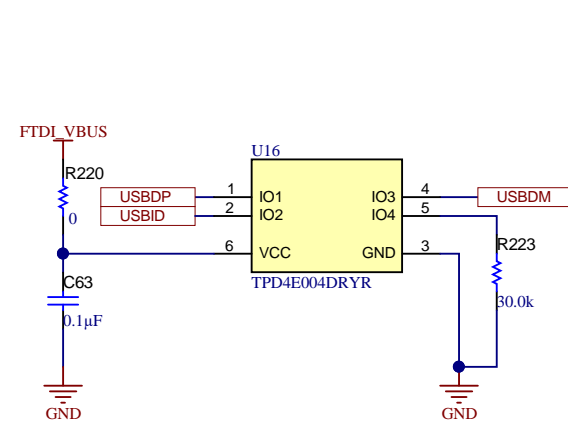
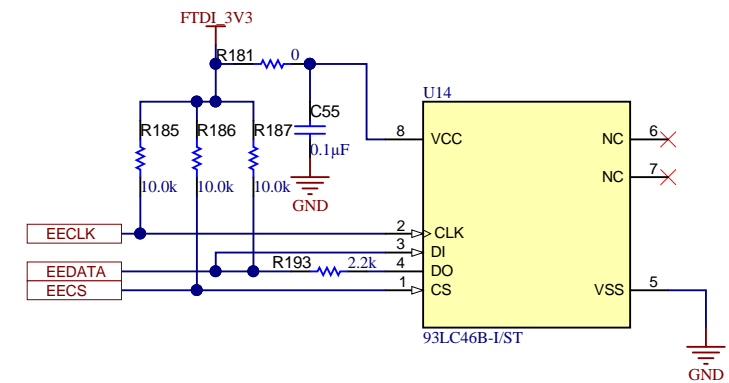

3.3V SUPPLY SELECTION JUMPER

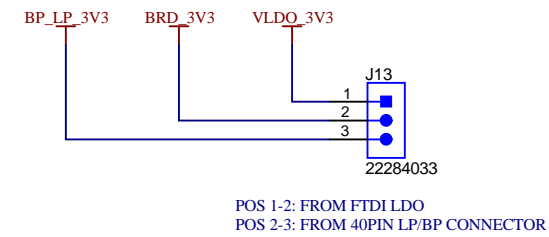

Texas Instruments and/or its licensors do not warrant the accuracy or completeness of this specification or any information contained therein. Texas Instruments and/or its licensors do not warrant that this design will meet the specifications, will be suitable for your application or fit for any particular purpose, or will operate in an implementation. Texas Instruments and/or its licensors do not warrant that the design is production worthy. You should completely validate and test your design implementation to confirm the system functionality for your application.

CAN TRANSCEIVER

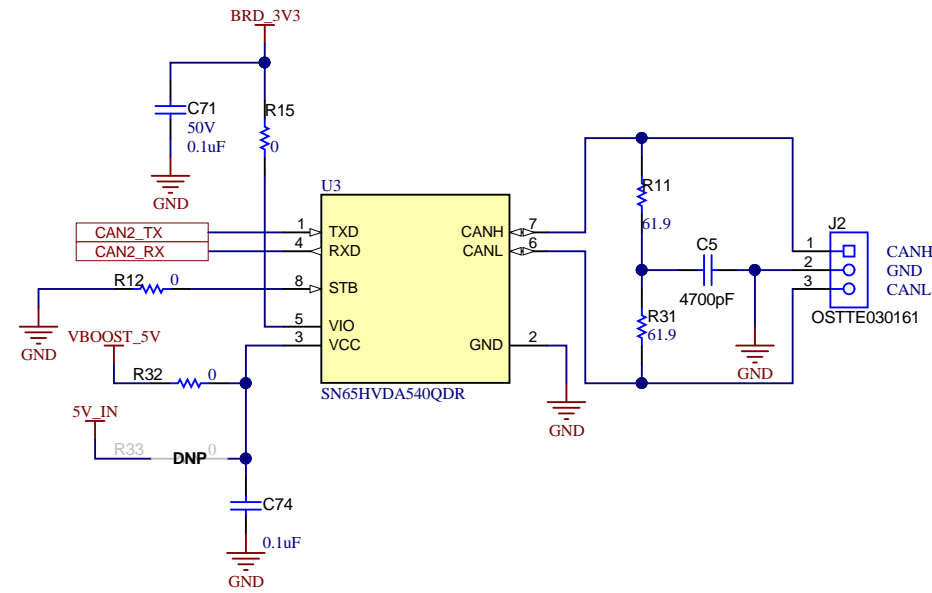

RESET & SOP STATUS INDICATION

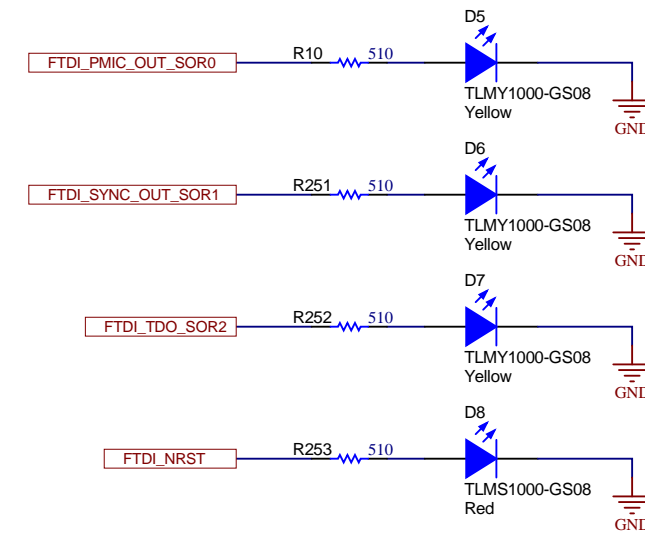

3.3V TO 5V BOOST CONVERTER

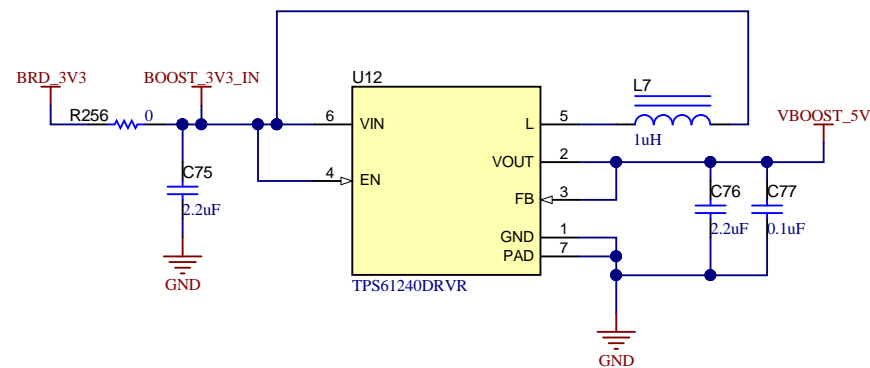

5V & 3.3V SUPPLY INDICATION

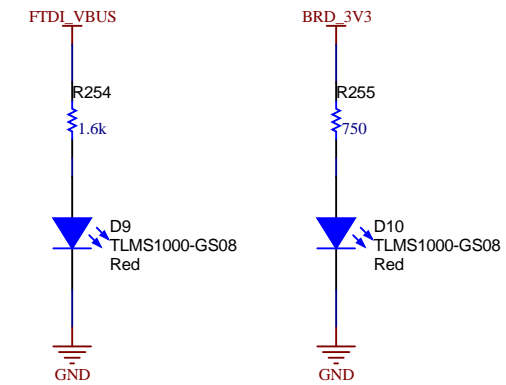

Texas Instruments and/or its licensors do not warrant the accuracy or completeness of this specification or any information contained therein. Texas Instruments and/or its licensors do not warrant that this design will meet the specifications, will be suitable for your application or fit for any particular purpose, or will operate in an implementation. Texas Instruments and/or its licensors do not warrant that the design is production worthy. You should completely validate and test your design implementation to confirm the system functionality for your application.

Orderable: MMWAVEICBOOST	Designed for: Public Release	Mod. Date: 5/2/2019
TID #: N/A	Project Title: MMWAVEICBOOST	
Number: PROC074	Rev: B	Sheet Title:
SVN Rev: Not in version control	Assembly Variant: 001	Sheet: 18 of 22
Drawn By: Chethan Kumar Y.B	File: PROC074B_CAN_Interface_LEDs.SchDoc	Size: B
Engineer: Chethan Kumar Y.B	Contact: http://www.ti.com/support	



ANALOG MUX BETWEEN FTDI, DCA & 40PIN HDR 1/2

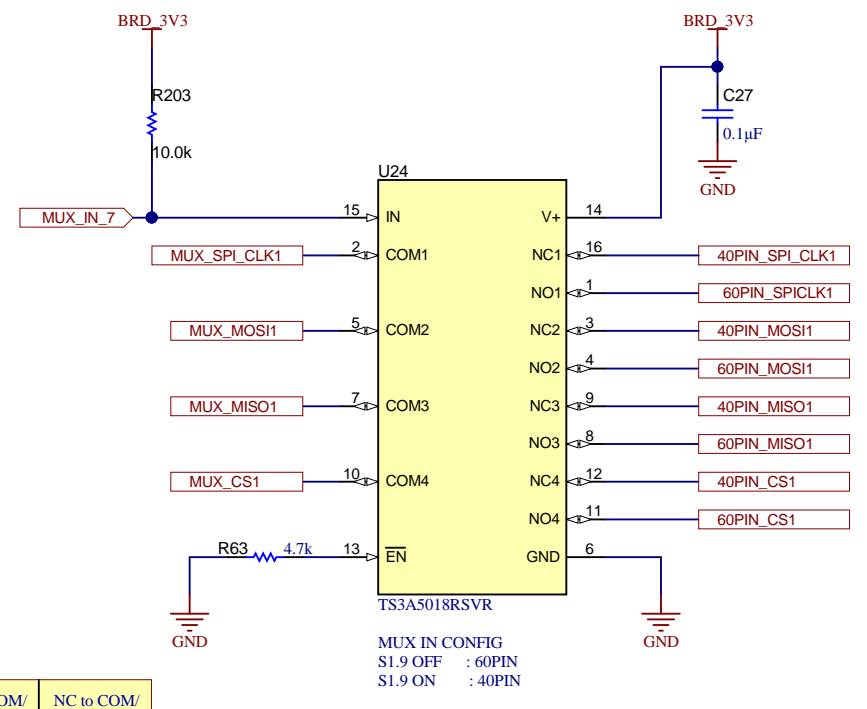
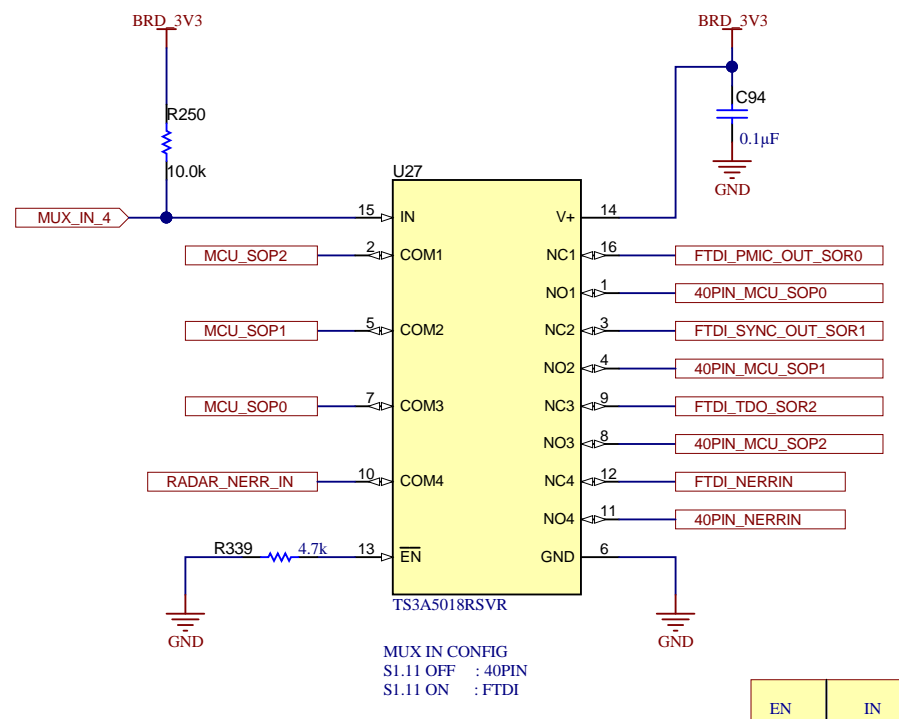
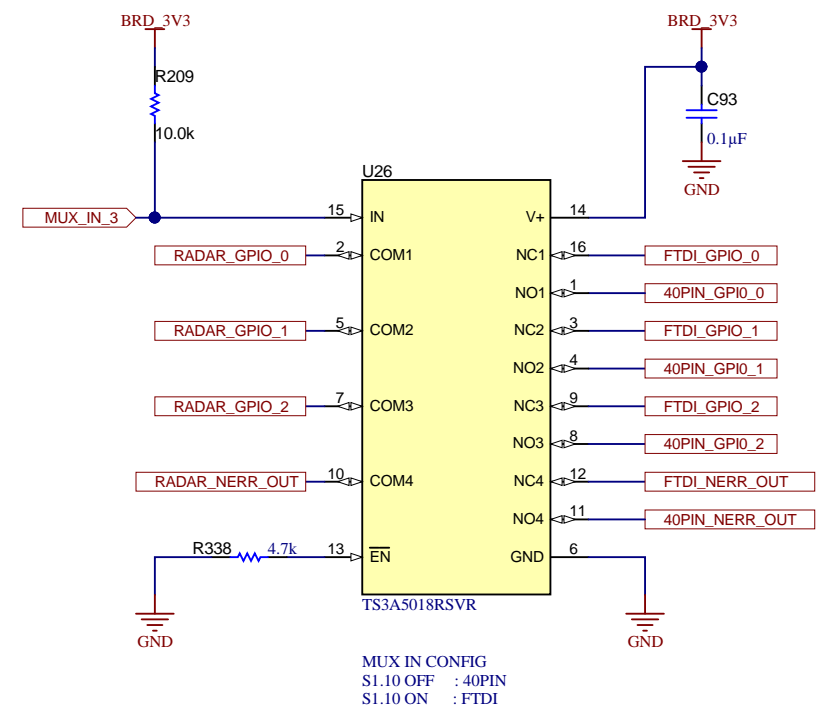
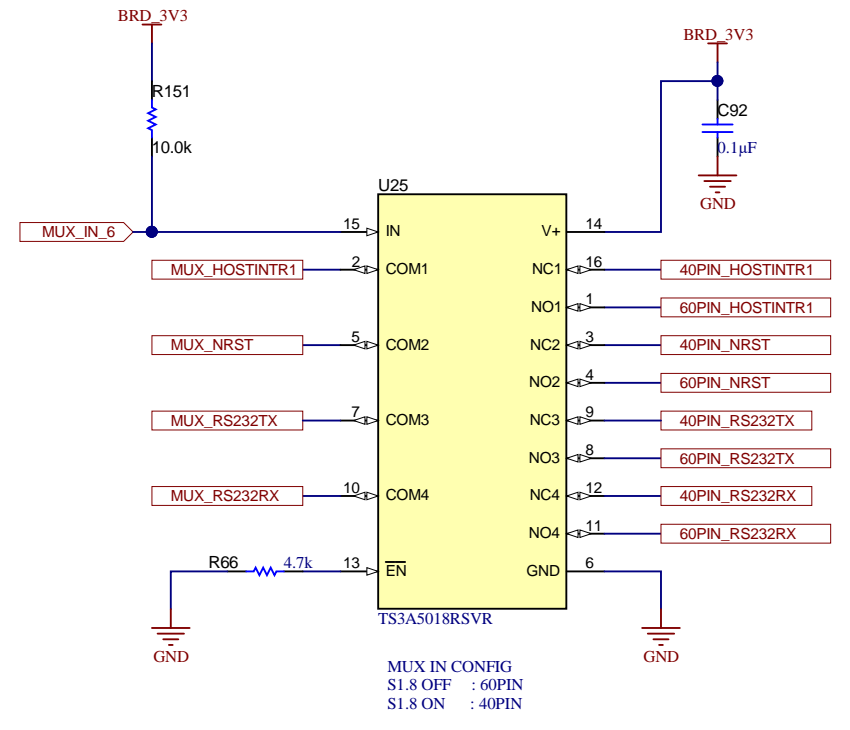
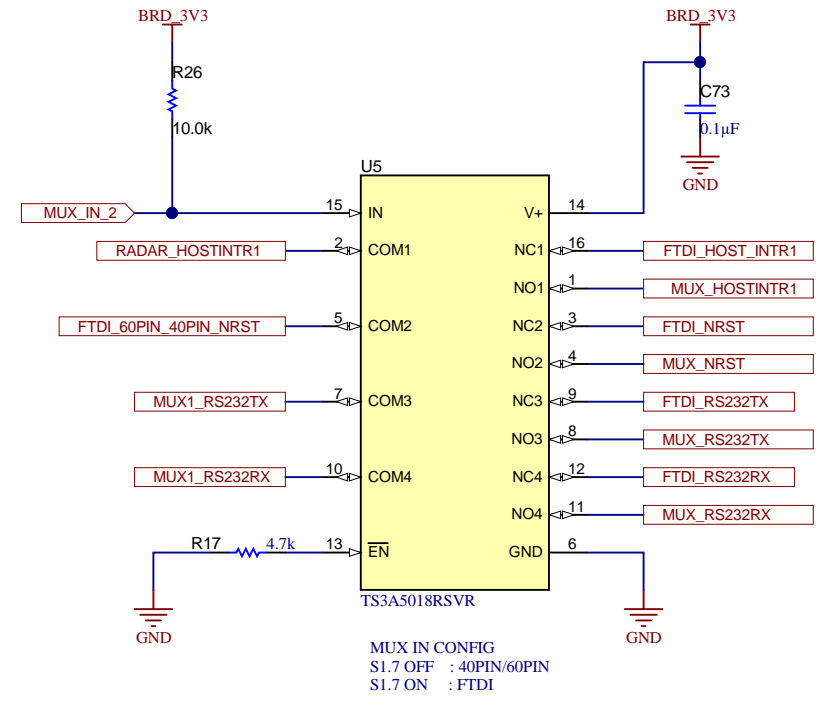
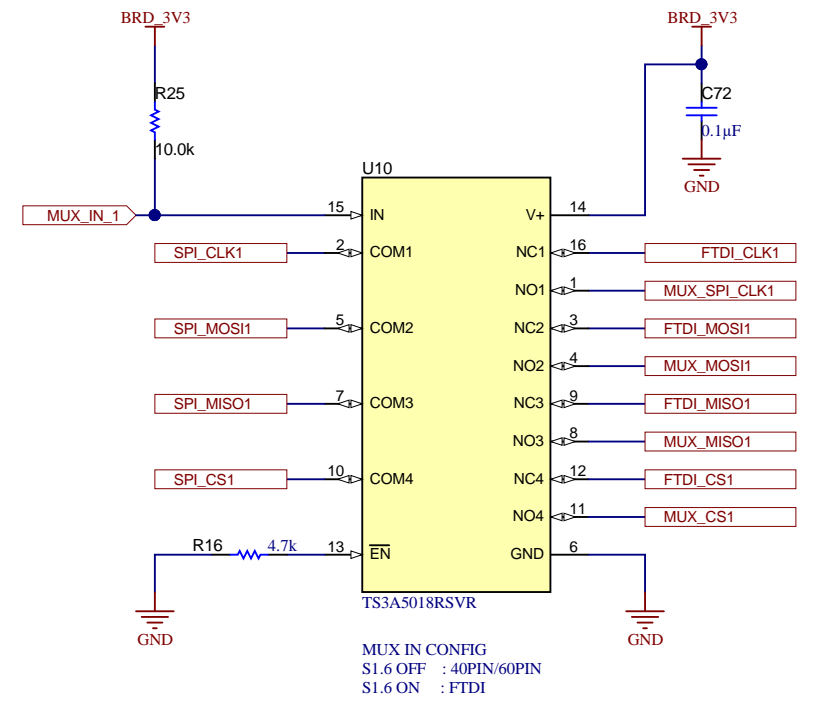

EN	IN	NO to COM/ COM to NO	NC to COM/ COM to NC
L	L	OFF	ON
L	H	ON	OFF
H	X	OFF	OFF

Texas Instruments and/or its licensors do not warrant the accuracy or completeness of this specification or any information contained therein. Texas Instruments and/or its licensors do not warrant that this design will meet the specifications, will be suitable for your application or fit for any particular purpose, or will operate in an implementation. Texas Instruments and/or its licensors do not warrant that the design is production worthy. You should completely validate and test your design implementation to confirm the system functionality for your application.

ANALOG MUX BETWEEN FTDI, DCA & 40PIN HDR (2/2)

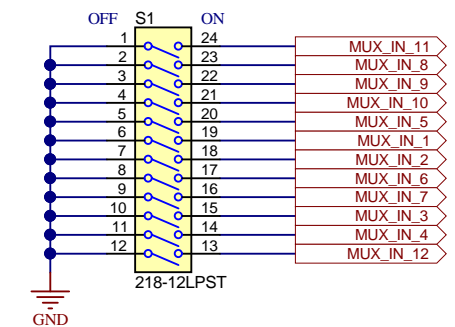
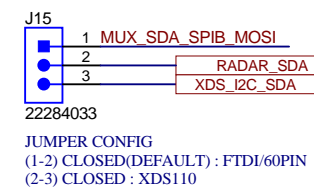
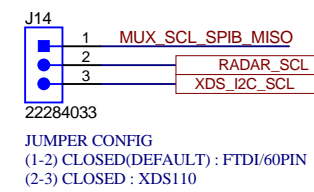
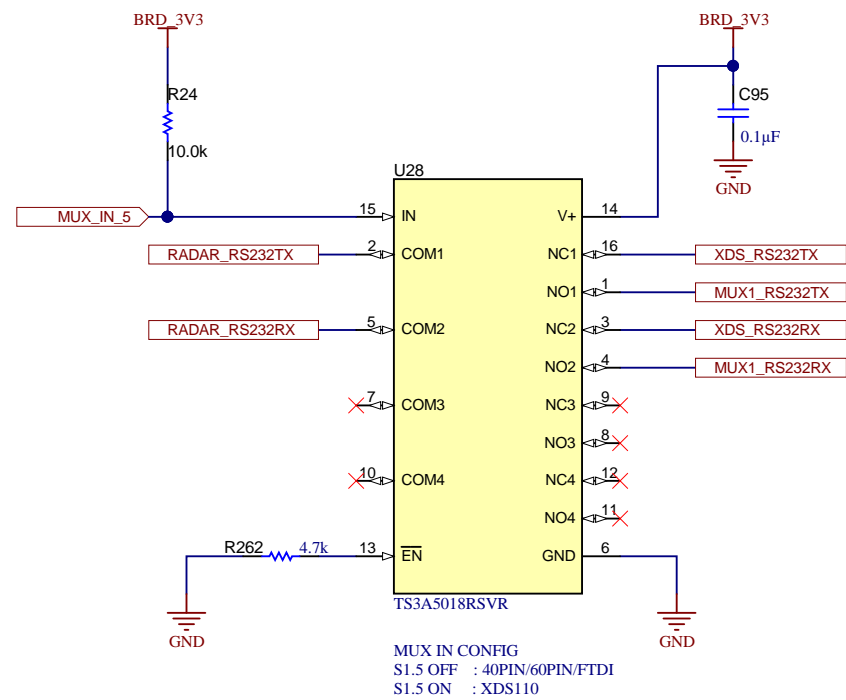
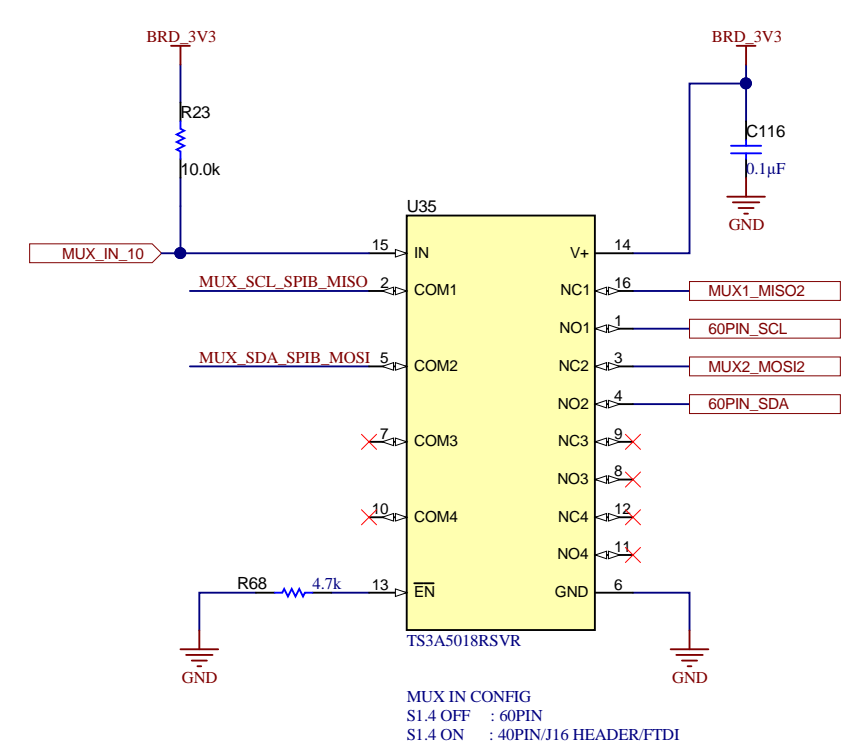
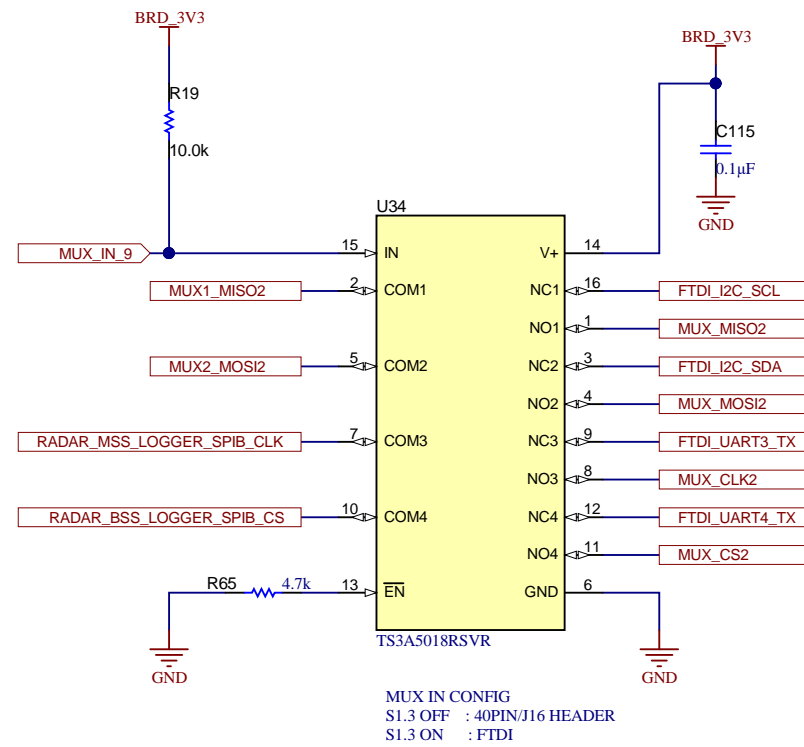
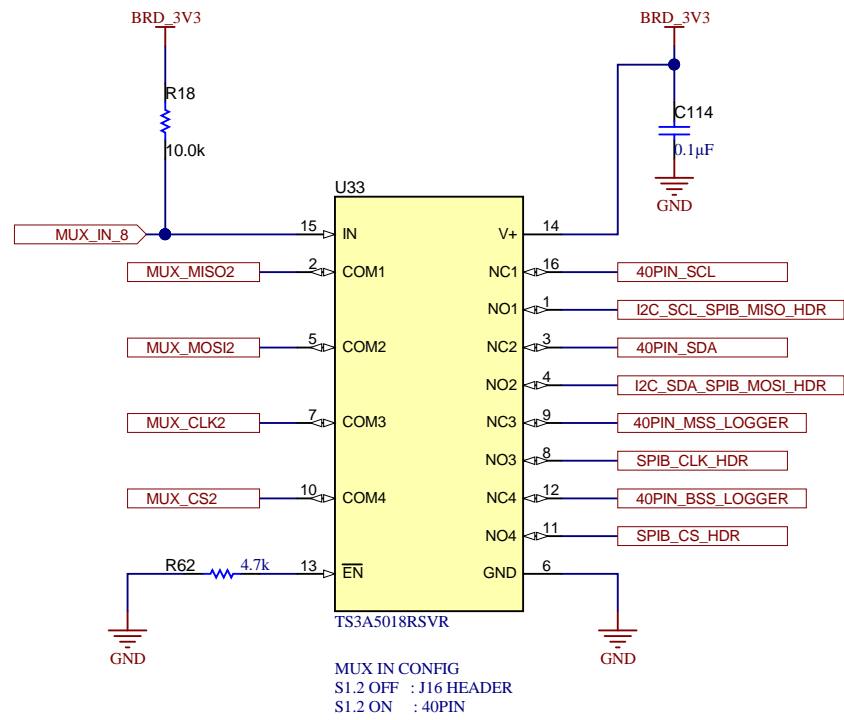

Texas Instruments and/or its licensors do not warrant the accuracy or completeness of this specification or any information contained therein. Texas Instruments and/or its licensors do not warrant that this design will meet the specifications, will be suitable for your application or fit for any particular purpose, or will operate in an implementation. Texas Instruments and/or its licensors do not warrant that the design is production worthy. You should completely validate and test your design implementation to confirm the system functionality for your application.

Orderable: MMWAVEICBOOST	Designed for: Public Release	Mod. Date: 10/12/2018
TID #: N/A	Project Title: MMWAVEICBOOST	
Number: PROC074	Rev: B	Sheet Title:
SVN Rev: Not in version control	Assembly Variant: 001	Sheet: 20 of 22
Drawn By:	File: PROC074B_Analog_Mux_1B.SchDoc	Size: B
Engineer: Chethan Kumar Y.B	Contact: http://www.ti.com/support	

60PIN HD CONNECTOR FOR DCA1000

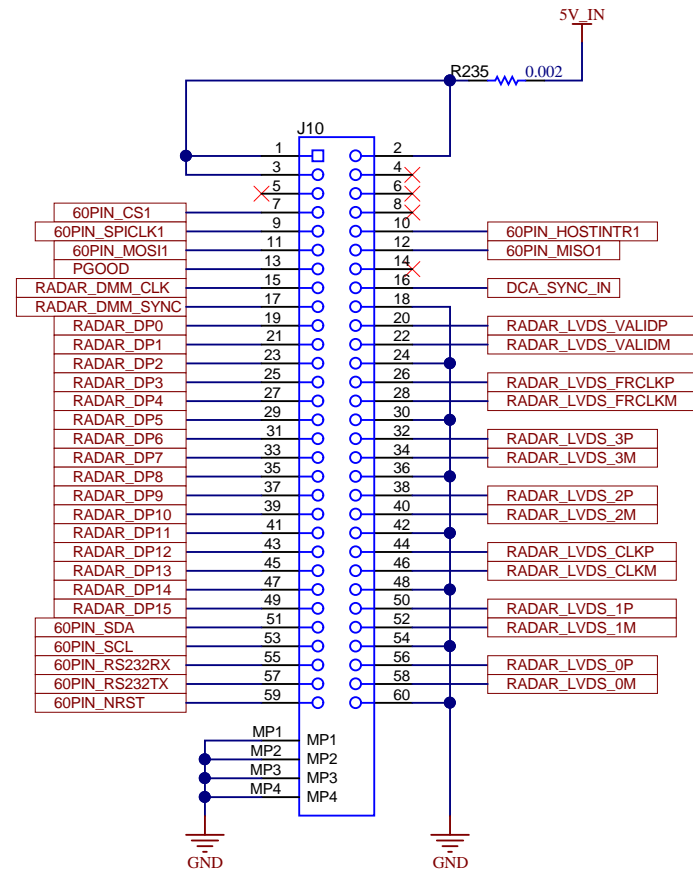

MIPI-60 DEBUG TRACE CONNECTOR

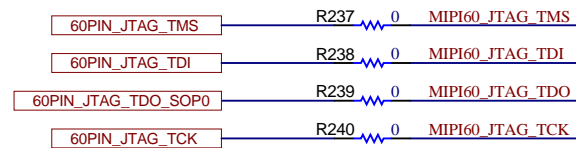
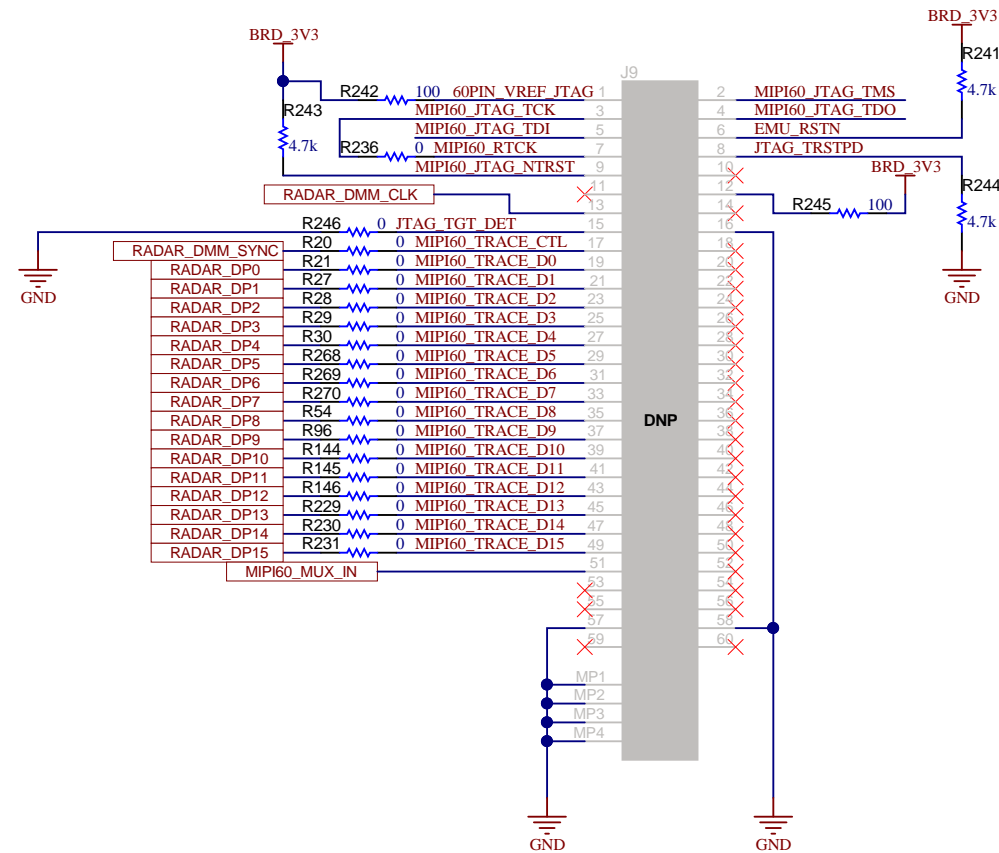

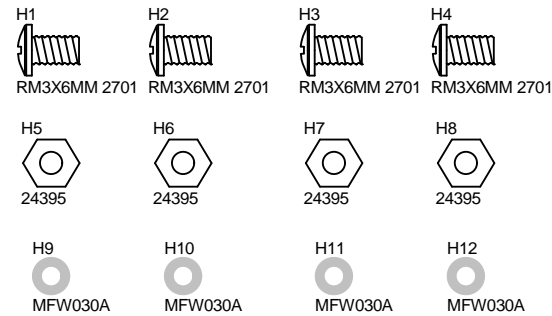

Open Top Jumper Sockets

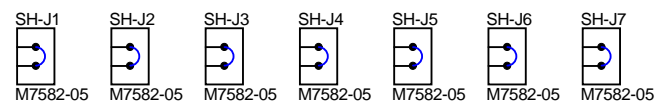

PCB Number: PROC074
PCB Rev: B

PCB LOGO
Texas Instruments



PCB LOGO
FCC disclaimer

PCB LOGO
WEEE logo



Variant/Label Table	
Variant	Label Text
001	MMWAVEICBOOST

LBL1
PCB Label
THT-14-423-10
Size: 0.65" x 0.20 "

ZZ1
Label Assembly Note
This Assembly Note is for PCB labels only

ZZ2
Assembly Note
These assemblies are ESD sensitive, ESD precautions shall be observed.

ZZ3
Assembly Note
These assemblies must be clean and free from flux and all contaminants. Use of no clean flux is not acceptable.

ZZ4
Assembly Note
These assemblies must comply with workmanship standards IPC-A-610 Class 2, unless otherwise specified.

Orderable: MMWAVEICBOOST	Designed for: Public Release	Mod. Date: 11/15/2018
TID #: N/A	Project Title: MMWAVEICBOOST	
Number: PROC074	Rev: B	Sheet Title:
SVN Rev: Not in version control	Assembly Variant: 001	Sheet: 22 of 22
Drawn By:	File: PROC074B_EVM_Hardware.SchDoc	Size: B
Engineer: Chethan Kumar Y.B	Contact: http://www.ti.com/support	



Texas Instruments and/or its licensors do not warrant the accuracy or completeness of this specification or any information contained therein. Texas Instruments and/or its licensors do not warrant that this design will meet the specifications, will be suitable for your application or fit for any particular purpose, or will operate in an implementation. Texas Instruments and/or its licensors do not warrant that the design is production worthy. You should completely validate and test your design implementation to confirm the system functionality for your application.