

WEBENCH[®] Design Report

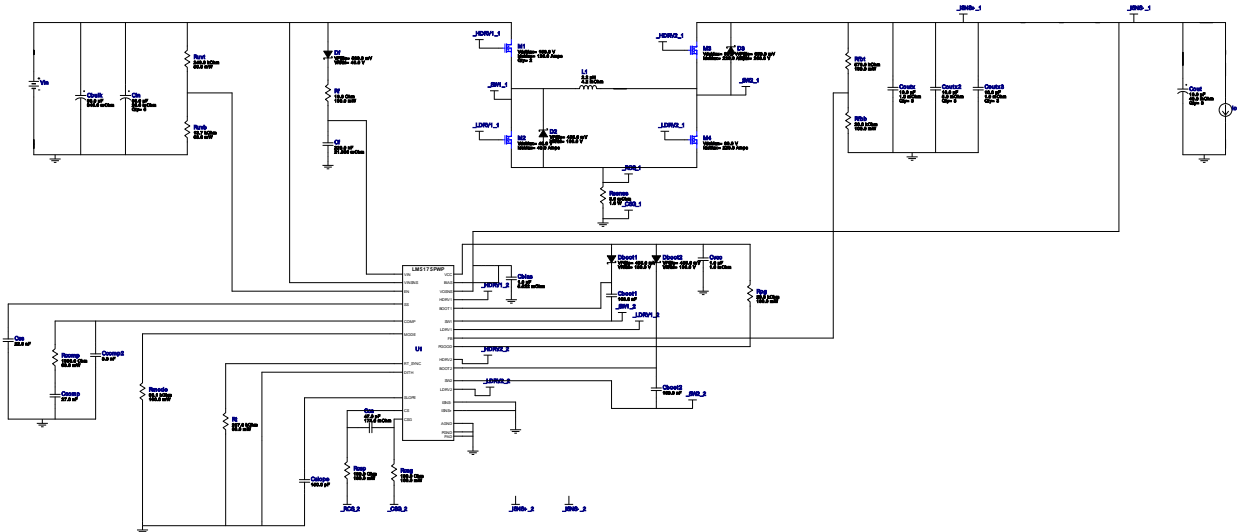





 Design : 8667 LM5175PWPR
 LM5175PWPR 24V-30V to 24.00V @ 16A











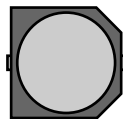

Design Alerts

Component Selection Information

Please note that since parallel FETs have been chosen in this design, schematic and PCB export features will not work

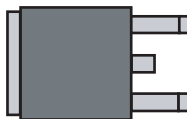
Electrical BOM

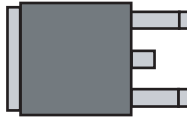
Name	Manufacturer	Part Number	Properties	Qty	Price	Footprint
Cbias	TDK	C1608X6S1H105K080AC Series= X6S	Cap= 1.0 uF ESR= 5.522 mOhm VDC= 50.0 V IRMS= 2.2162 A	1	\$0.05	 0603 5 mm ²
Cboot1	AVX	08053C104JAZ2A Series= X7R	Cap= 100.0 nF VDC= 25.0 V IRMS= 0.0 A	1	\$0.06	 0805 7 mm ²
Cboot2	AVX	08053C104JAZ2A Series= X7R	Cap= 100.0 nF VDC= 25.0 V IRMS= 0.0 A	1	\$0.06	 0805 7 mm ²
Cbulk	Nichicon	UUD1V680MCL1GS Series= uD	Cap= 68.0 uF ESR= 340.0 mOhm VDC= 35.0 V IRMS= 280.0 mA	1	\$0.12	 SM_RADIAL_6.3BMM 80 mm ²
Ccomp	Kemet	C1812C273J5GACTU Series= C0G/NP0	Cap= 27.0 nF VDC= 50.0 V IRMS= 0.0 A	1	\$0.71	 1812 23 mm ²
Ccomp2	TDK	C2012C0G1H332J060AA Series= C0G/NP0	Cap= 3.3 nF VDC= 50.0 V IRMS= 0.0 A	1	\$0.03	 0805 7 mm ²
Ccs	AVX	06035A470JAT2A Series= C0G/NP0	Cap= 47.0 pF ESR= 174.0 mOhm VDC= 50.0 V IRMS= 0.0 A	1	\$0.01	 0603 5 mm ²
Cf	TDK	CGA3E3X7R1H224K080AB Series= X7R	Cap= 220.0 nF ESR= 21.699 mOhm VDC= 50.0 V IRMS= 1.125 A	1	\$0.03	 0603 5 mm ²

Name	Manufacturer	Part Number	Properties	Qty	Price	Footprint
Cin	Panasonic	50SVPF68M Series= SVPF	Cap= 68.0 uF ESR= 20.0 mOhm VDC= 50.0 V IRMS= 4.3 A	5	\$0.95	 CAPSMT_62_F12 151 mm ²
Cout	Panasonic	50SVPF10M Series= SVPF	Cap= 10.0 uF ESR= 40.0 mOhm VDC= 50.0 V IRMS= 2.5 A	3	\$0.41	 CAPSMT_62_F61 74 mm ²
Coutx	MuRata	GRM32ER71H106MA12 Series= X7R	Cap= 10.0 uF ESR= 1.0 mOhm VDC= 50.0 V IRMS= 0.0 A	3	\$0.33	 1210_270 15 mm ²
Coutx2	TDK	C5750X7S2A106M230KB Series= X7S	Cap= 10.0 uF ESR= 5.0 mOhm VDC= 100.0 V IRMS= 6.45 A	3	\$0.86	 2220 54 mm ²
Coutx3	MuRata	GRM32ER71H106MA12 Series= X7R	Cap= 10.0 uF ESR= 1.0 mOhm VDC= 50.0 V IRMS= 0.0 A	3	\$0.33	 1210_270 15 mm ²
Cslope	Samsung Electro-Mechanics	CL10C151JB8NNNC Series= C0G/NP0	Cap= 150.0 pF VDC= 50.0 V IRMS= 0.0 A	1	\$0.01	 0603 5 mm ²
Css	TDK	CGA4J2C0G1H223J125AA Series= C0G/NP0	Cap= 22.0 nF VDC= 50.0 V IRMS= 0.0 A	1	\$0.08	 0805 7 mm ²
Cvcc	Taiyo Yuden	EMK107B7105KA-T Series= X7R	Cap= 1.0 uF ESR= 1.0 mOhm VDC= 16.0 V IRMS= 0.0 A	1	\$0.02	 0603 5 mm ²
D2	STMicroelectronics	STPS20M100SG-TR	VF@Io= 455.0 mV VRRM= 100.0 V	1	\$1.33	 DDPAK 210 mm ²
D3	SMC Diode Solutions	SBRD10200TR	VF@Io= 950.0 mV VRRM= 200.0 V	1	\$0.12	 DPAK 102 mm ²
Dboot1	STMicroelectronics	STPS20M100SG-TR	VF@Io= 455.0 mV VRRM= 100.0 V	1	\$1.33	 DDPAK 210 mm ²
Dboot2	STMicroelectronics	STPS20M100SG-TR	VF@Io= 455.0 mV VRRM= 100.0 V	1	\$1.33	 DDPAK 210 mm ²
Df	Diodes Inc.	B240A-13-F	VF@Io= 500.0 mV VRRM= 40.0 V	1	\$0.09	 SMA 37 mm ²
L1	Bourns	SRP1270-2R2M	L= 2.2 uH 4.2 mOhm	1	\$0.72	 SRP1270 246 mm ²

Name	Manufacturer	Part Number	Properties	Qty	Price	Footprint
M1	Infineon Technologies	IPP051N15N5AKSA1	VdsMax= 150.0 V IdsMax= 120.0 Amps	2	\$3.42	 TO-220-3 127 mm ²
M2	Infineon Technologies	IPZ40N04S5L4R8ATMA1	VdsMax= 40.0 V IdsMax= 40.0 Amps	1	\$0.40	PG-TSDSON-8-32 18 mm ²
M3	ON Semiconductor	NTP5860NG	VdsMax= 60.0 V IdsMax= 220.0 Amps	1	\$1.44	 TO-220AB 79 mm ²
M4	ON Semiconductor	NTP5860NG	VdsMax= 60.0 V IdsMax= 220.0 Amps	1	\$1.44	 TO-220AB 79 mm ²
Rcomp	Vishay-Dale	CRCW04021K00FKED Series= CRCW..e3	Res= 1000.0 Ohm Power= 63.0 mW Tolerance= 1.0%	1	\$0.01	 0402 3 mm ²
Rcsg	Vishay-Dale	CRCW0603100RFKEA Series= CRCW..e3	Res= 100.0 Ohm Power= 100.0 mW Tolerance= 1.0%	1	\$0.01	 0603 5 mm ²
Rcsp	Vishay-Dale	CRCW0603100RFKEA Series= CRCW..e3	Res= 100.0 Ohm Power= 100.0 mW Tolerance= 1.0%	1	\$0.01	 0603 5 mm ²
Rf	Vishay-Dale	CRCW060310R0FKEA Series= CRCW..e3	Res= 10.0 Ohm Power= 100.0 mW Tolerance= 1.0%	1	\$0.01	 0603 5 mm ²
Rfbb	Vishay-Dale	CRCW060320K0FKEA Series= CRCW..e3	Res= 20.0 kOhm Power= 100.0 mW Tolerance= 1.0%	1	\$0.01	 0603 5 mm ²
Rfbt	Yageo	RC0603FR-07576KL Series= ?	Res= 576.0 kOhm Power= 100.0 mW Tolerance= 1.0%	1	\$0.01	 0603 5 mm ²
Rmode	Vishay-Dale	CRCW060393K1FKEA Series= CRCW..e3	Res= 93.1 kOhm Power= 100.0 mW Tolerance= 1.0%	1	\$0.01	 0603 5 mm ²
Rpg	Vishay-Dale	CRCW060320K0FKEA Series= CRCW..e3	Res= 20.0 kOhm Power= 100.0 mW Tolerance= 1.0%	1	\$0.01	 0603 5 mm ²
Rsense	Stackpole Electronics Inc	CSNL1206FT3L00 Series= CSNL	Res= 3.0 mOhm Power= 1.0 W Tolerance= 1.0%	1	\$0.20	 1206 11 mm ²
Rt	Vishay-Dale	CRCW0402267KFKED Series= CRCW..e3	Res= 267.0 kOhm Power= 63.0 mW Tolerance= 1.0%	1	\$0.01	 0402 3 mm ²
Ruvb	Vishay-Dale	CRCW040213K7FKED Series= CRCW..e3	Res= 13.7 kOhm Power= 63.0 mW Tolerance= 1.0%	1	\$0.01	 0402 3 mm ²
Ruvt	Yageo	RC0201FR-07249KL Series= ?	Res= 249.0 kOhm Power= 50.0 mW Tolerance= 1.0%	1	\$0.01	 0201 2 mm ²
U1	Texas Instruments	LM5175PWPR	Switcher	1	\$2.73	 PWP0028F_N 98 mm ²

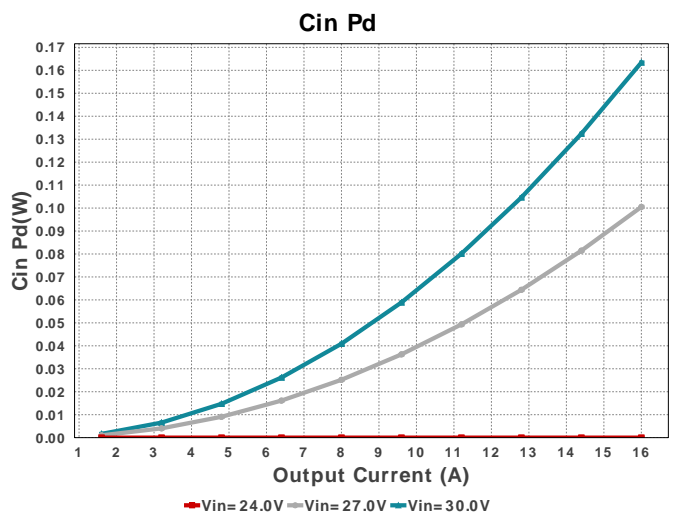
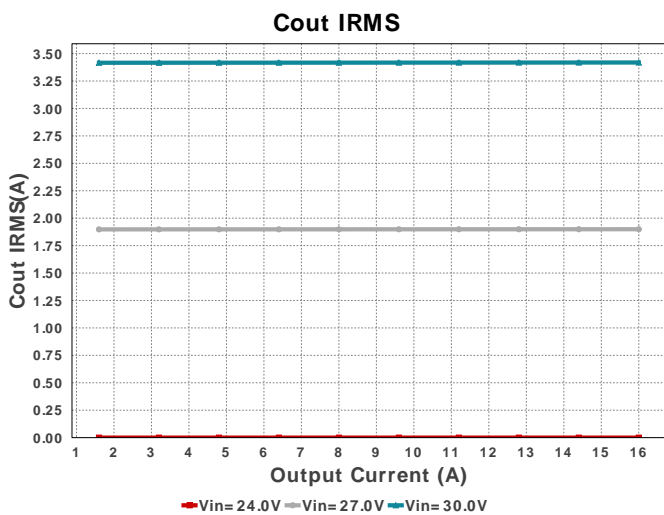
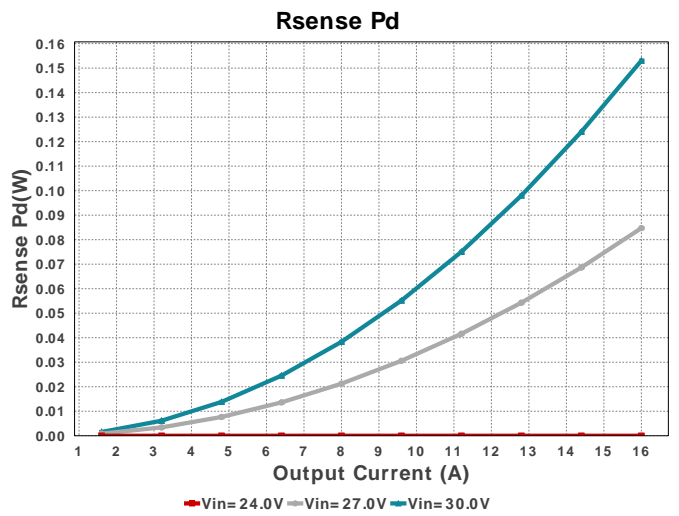
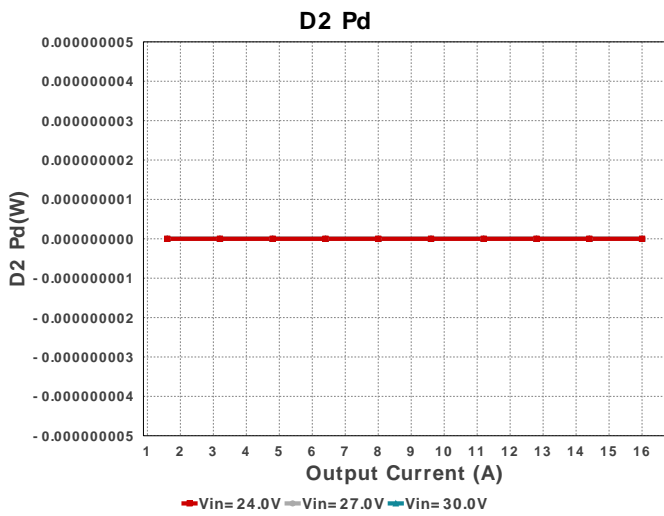
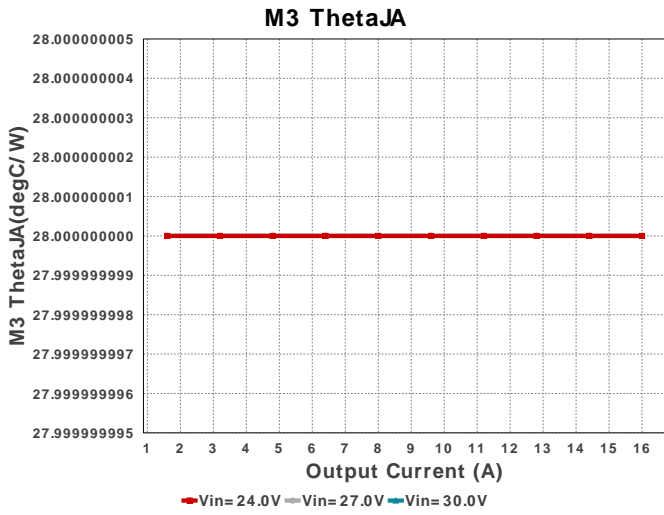

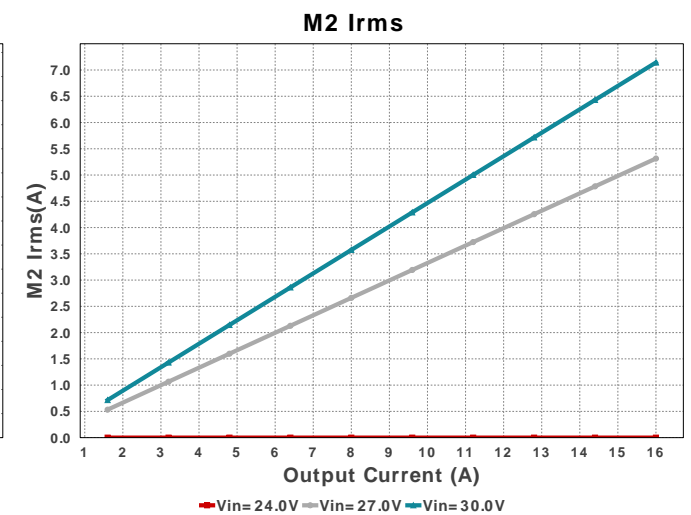
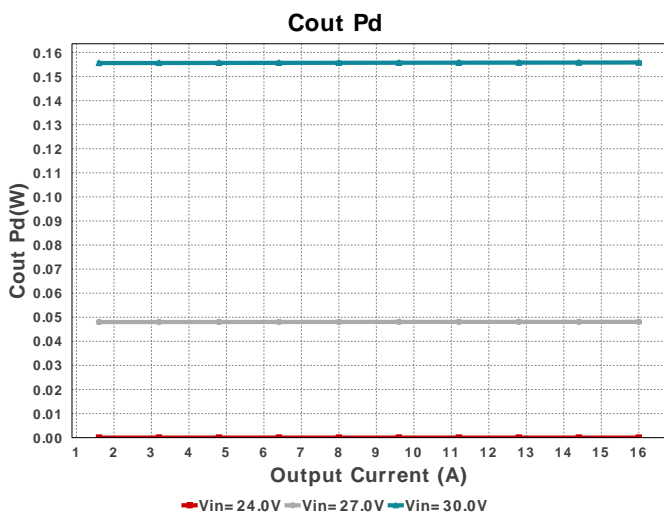
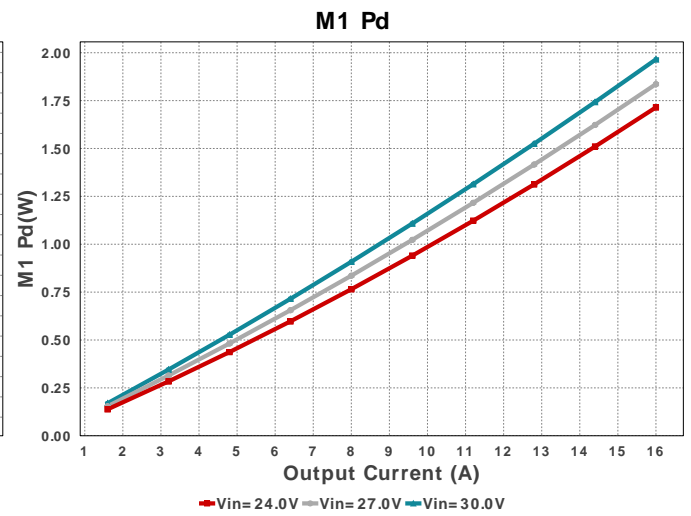
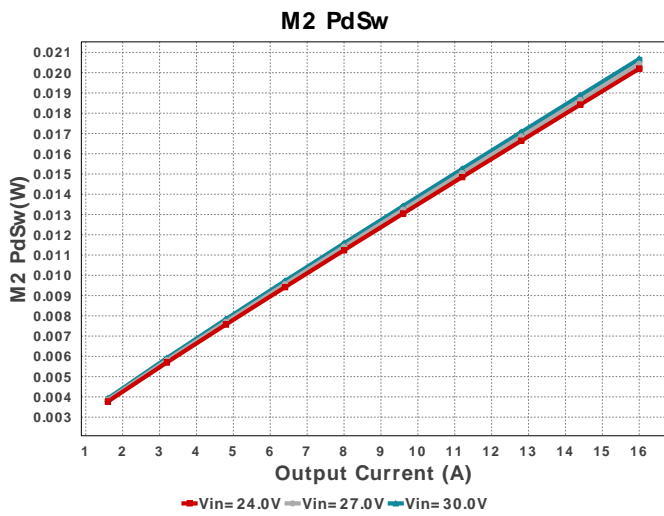
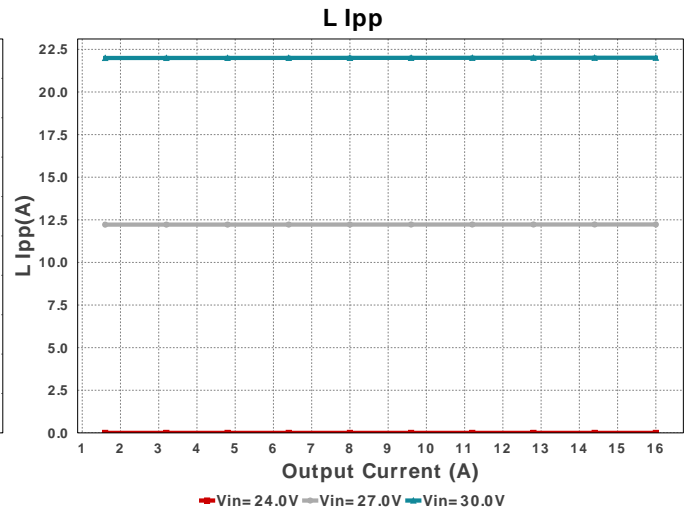
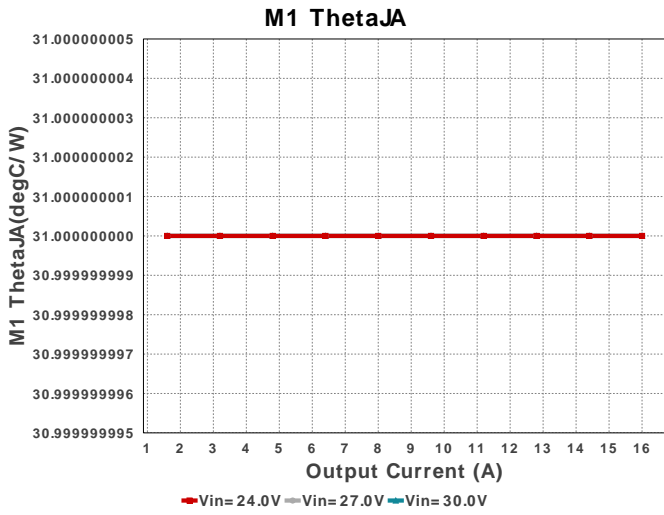

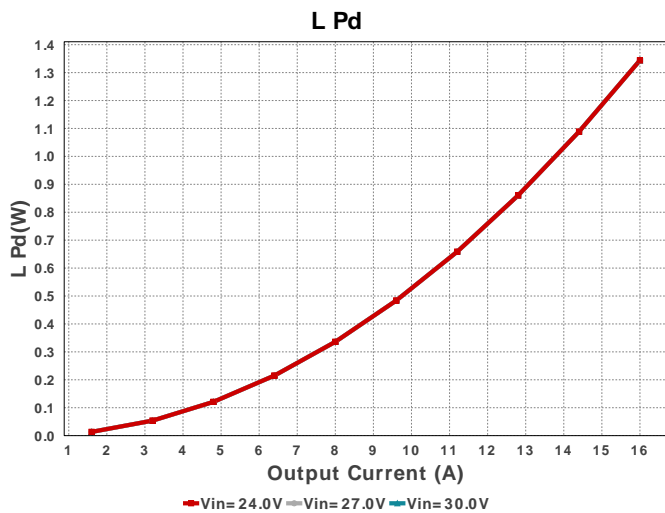
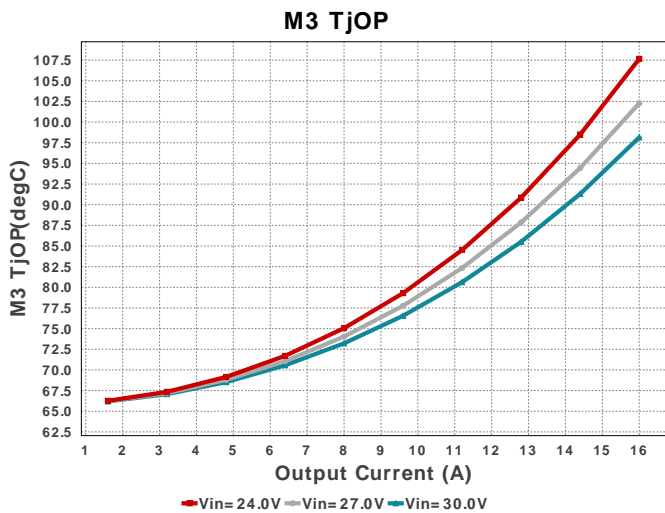
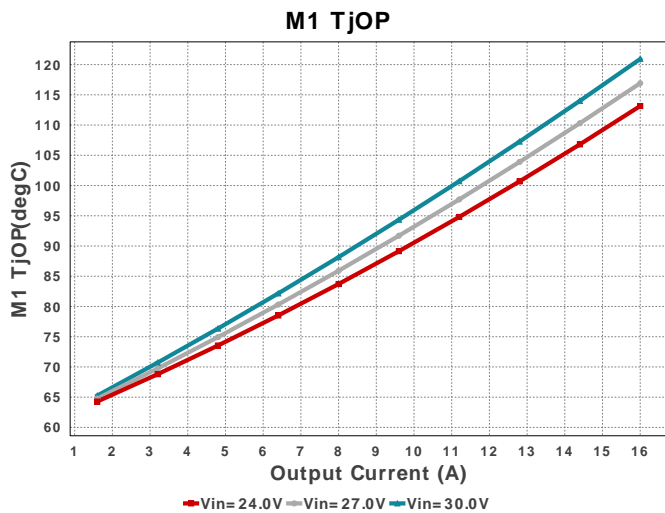
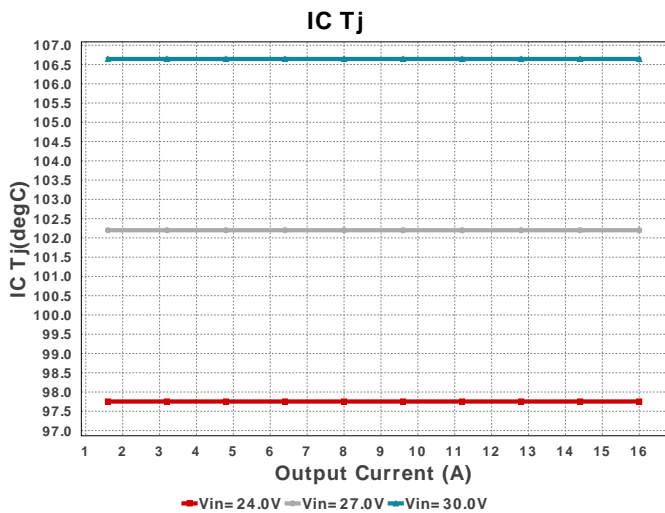
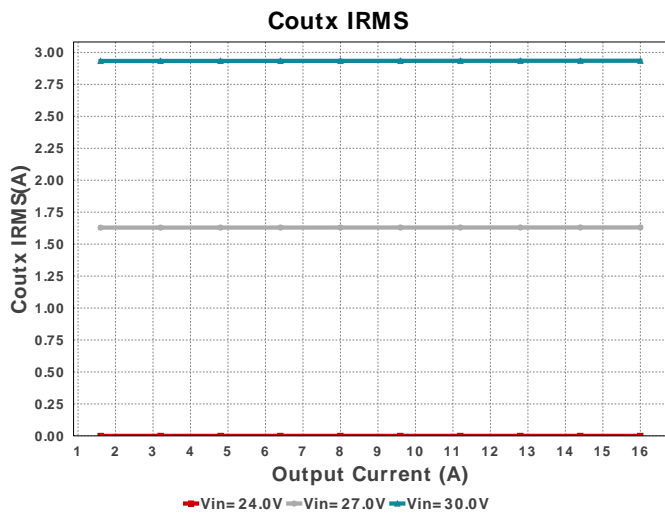
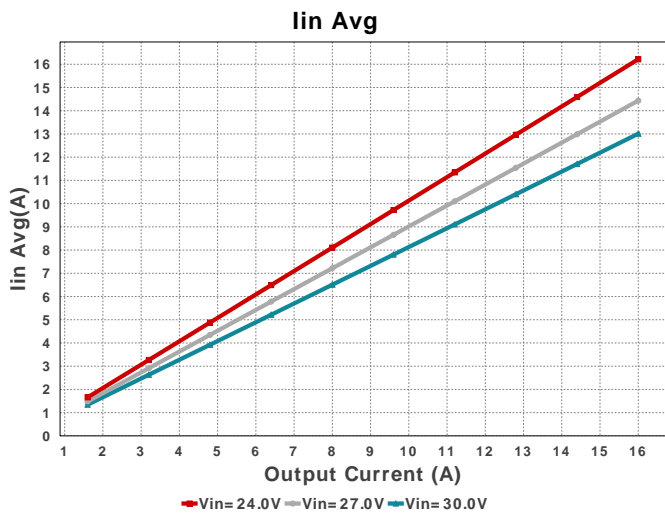

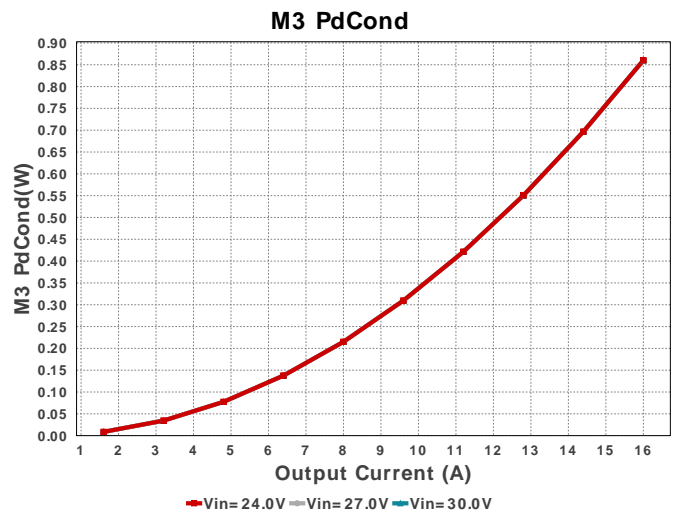
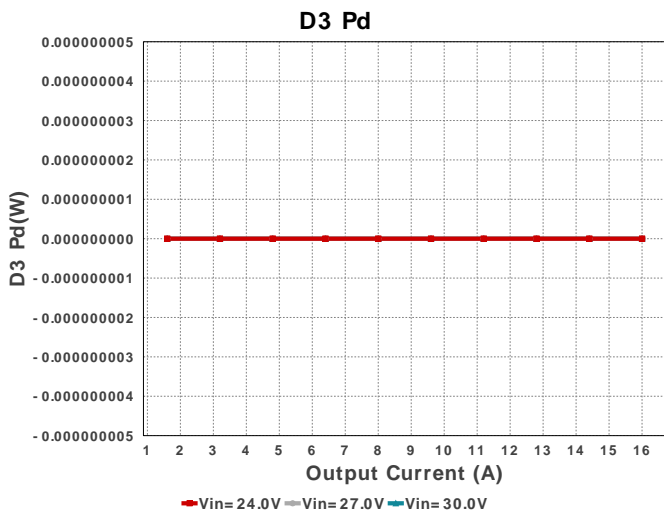
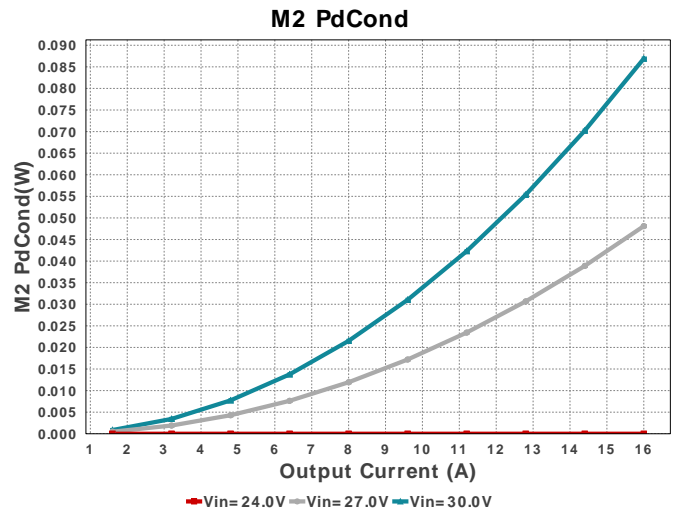
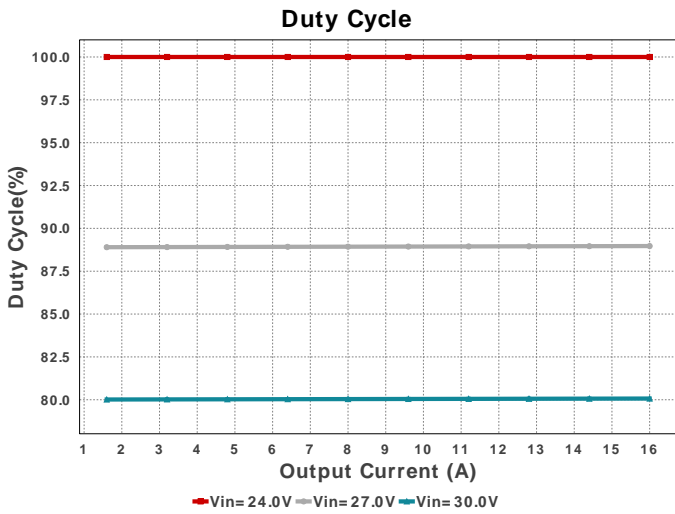
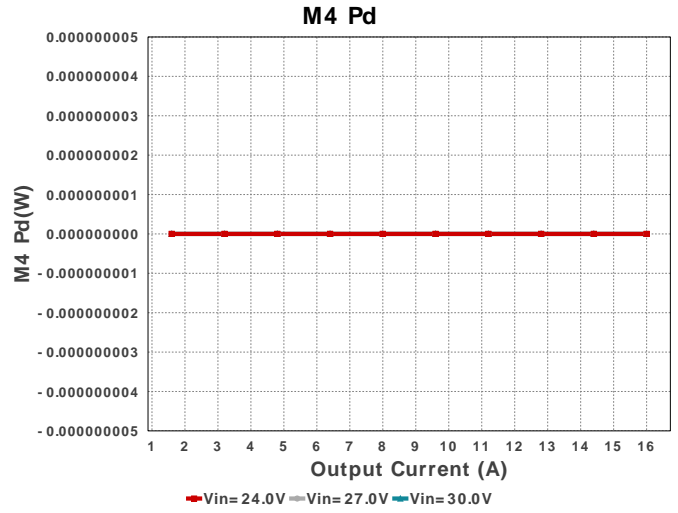
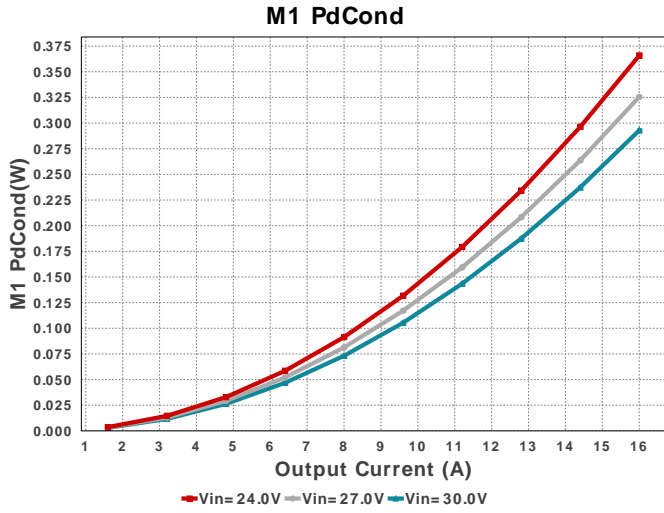

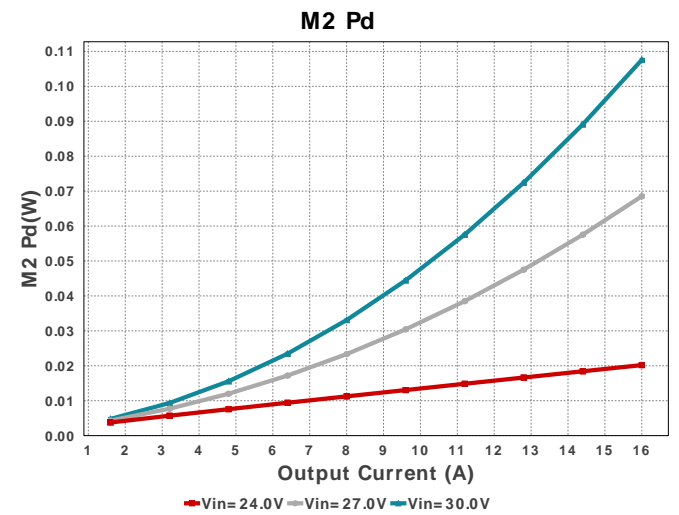
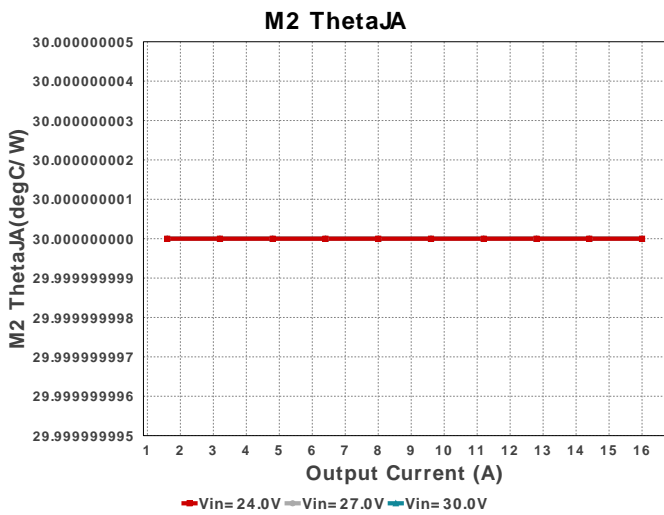
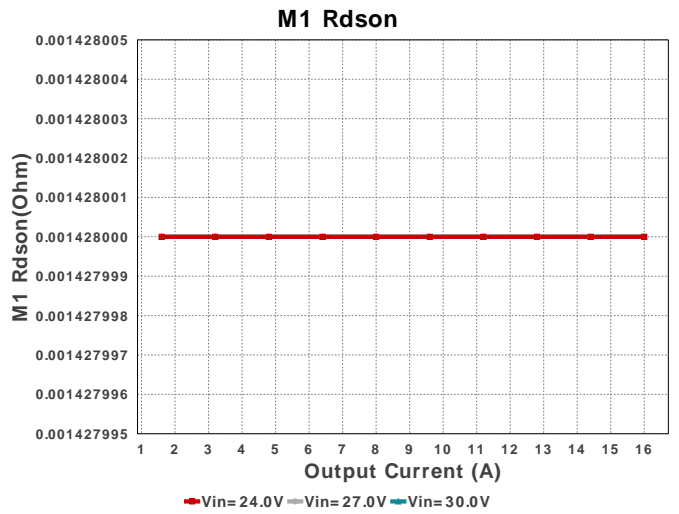
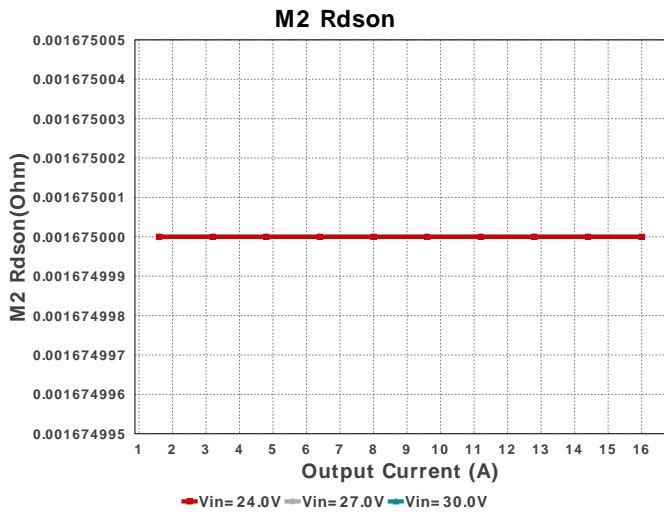
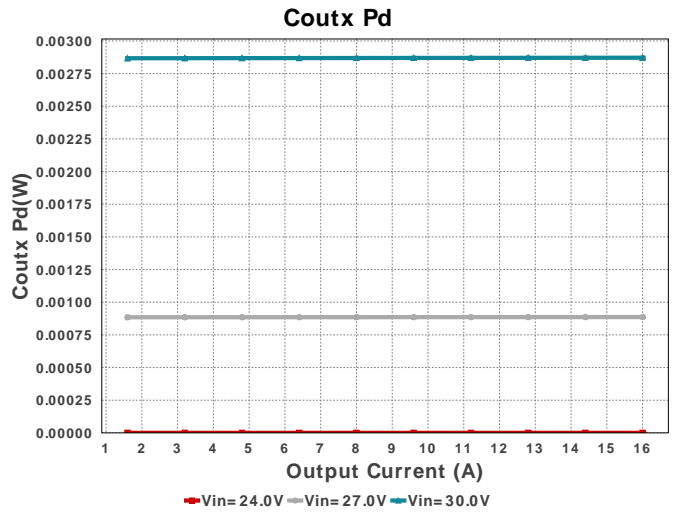
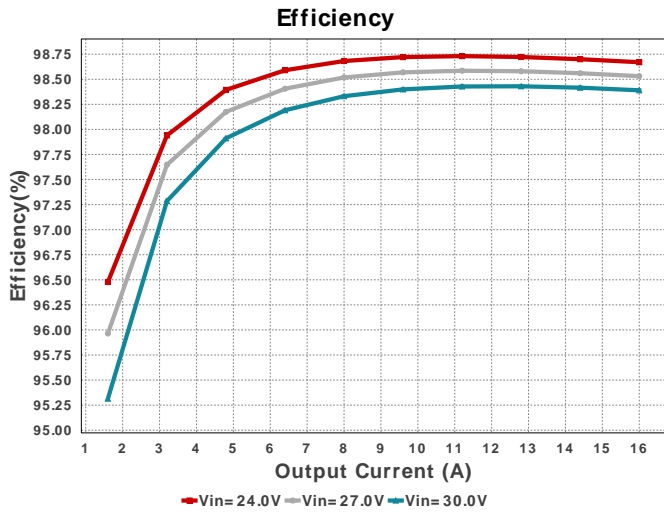

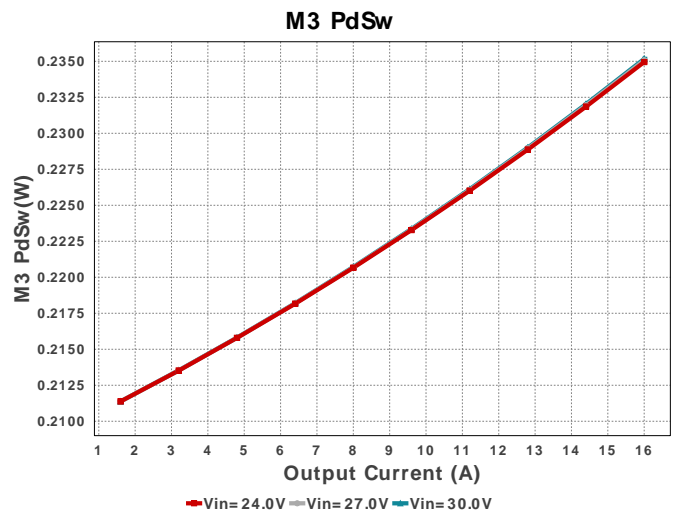
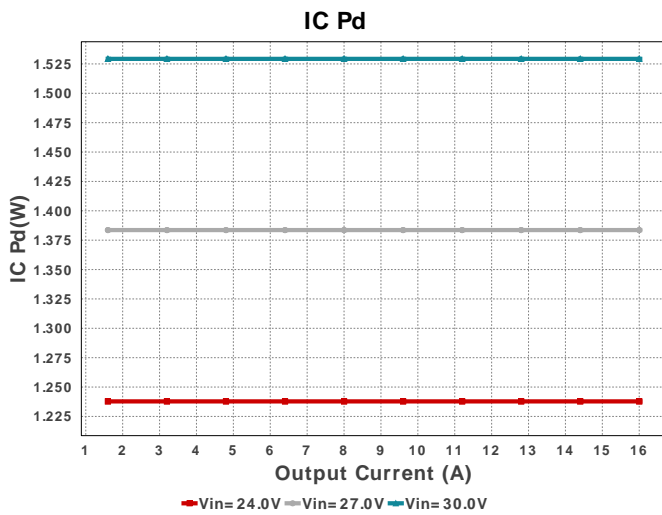
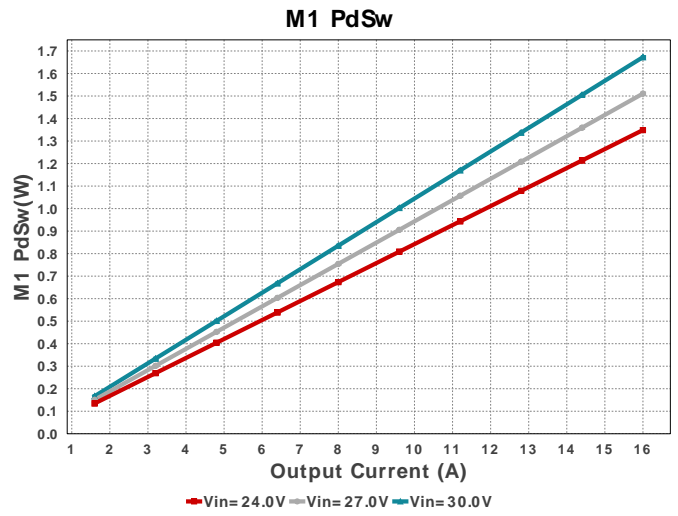
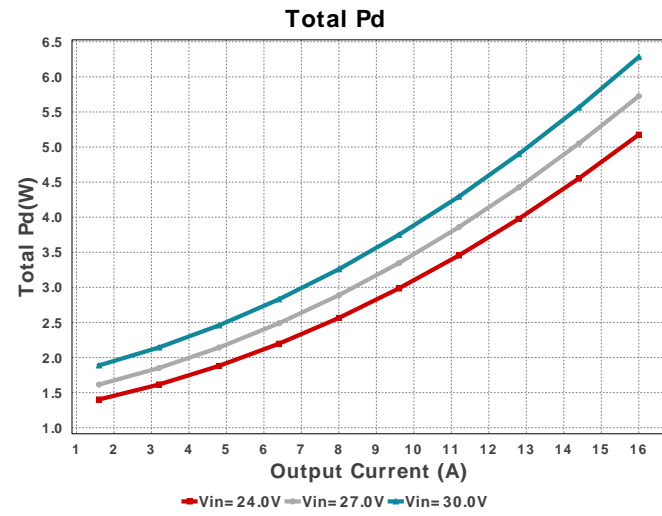
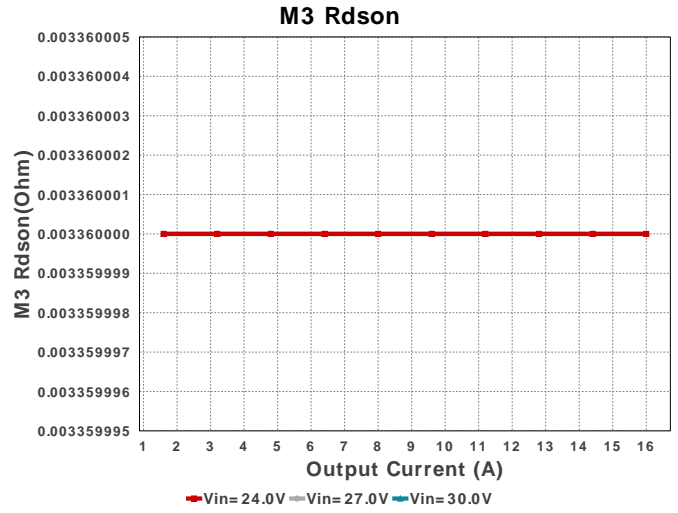
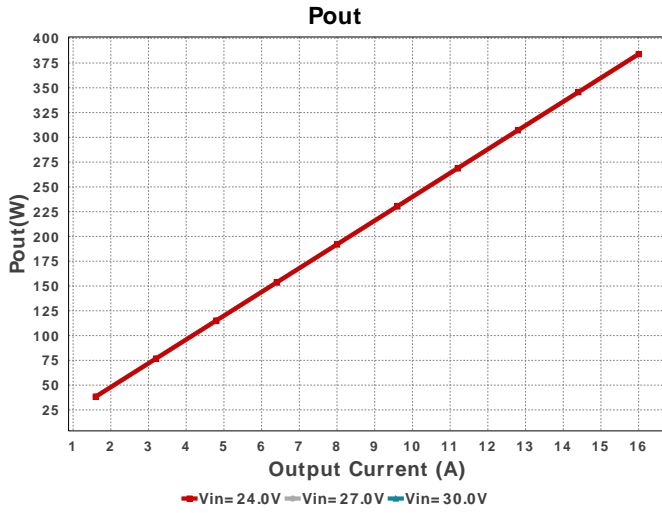

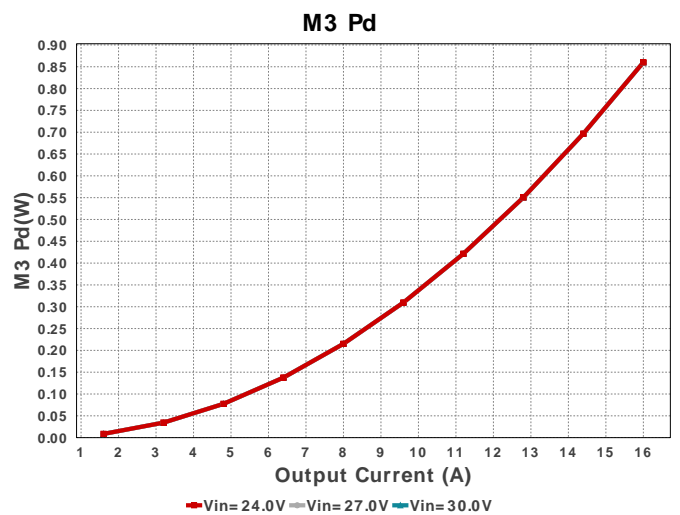
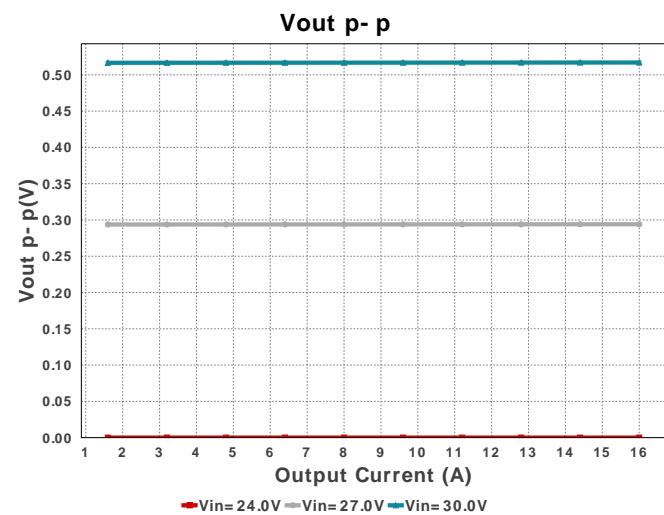
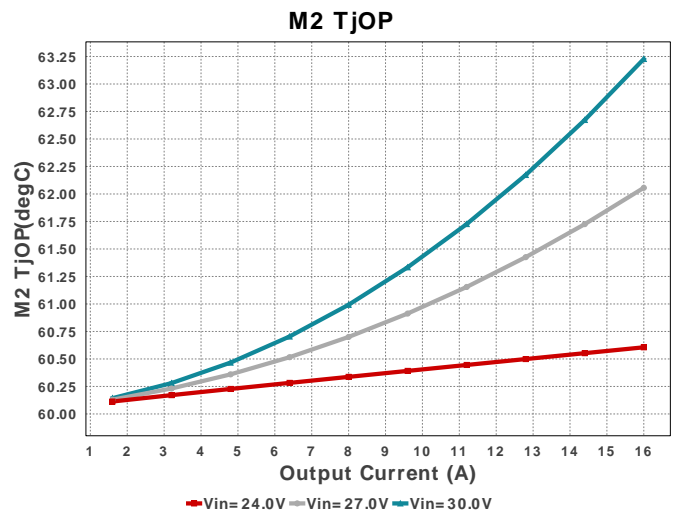
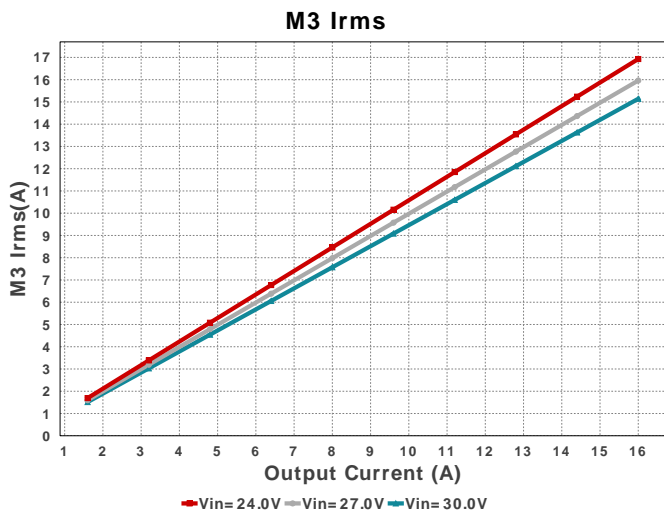
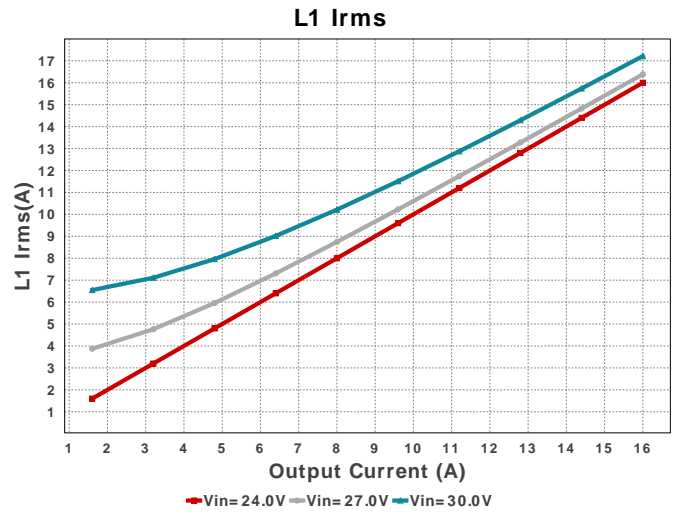
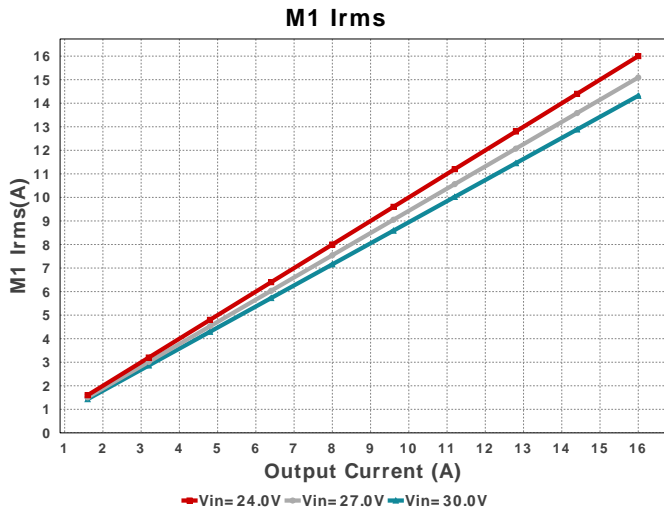

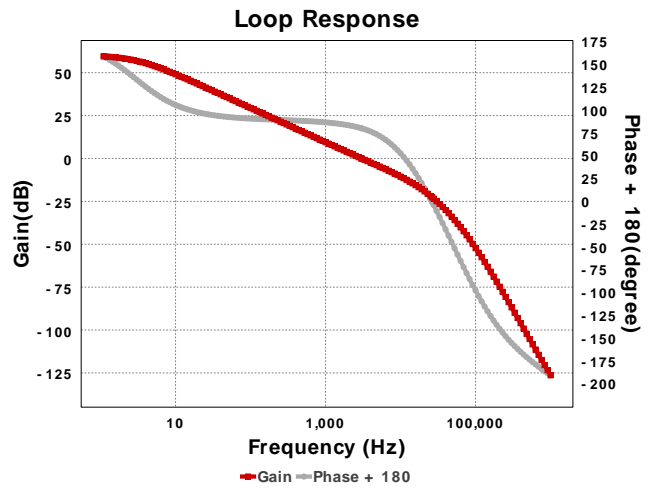
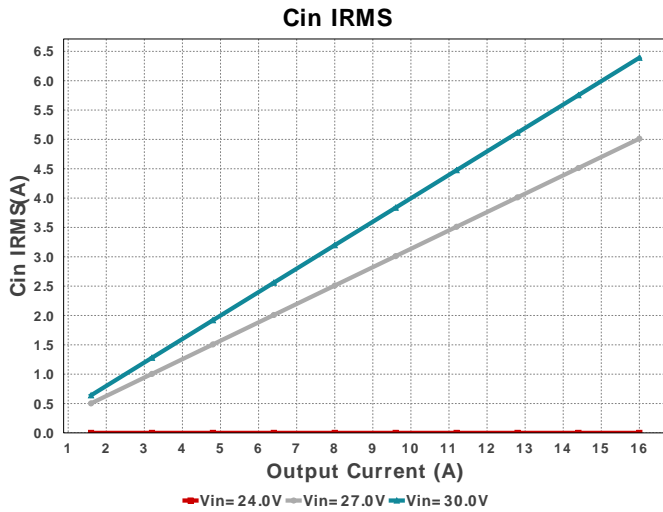

Operating Values

#	Name	Value	Category	Description
1.	BOM Count	52		Total Design BOM count
2.	Total BOM	\$29.8		Total BOM Cost
3.	Cin IRMS	6.392 A	Capacitor	Input capacitor RMS ripple current
4.	Cin Pd	163.41 mW	Capacitor	Input capacitor power dissipation
5.	Cout IRMS	3.419 A	Capacitor	Output capacitor RMS ripple current
6.	Cout Pd	155.84 mW	Capacitor	Output capacitor power dissipation
7.	Coutx IRMS	2.935 A	Capacitor	Output capacitor_x RMS ripple current
8.	Coutx Pd	2.871 mW	Capacitor	Output capacitor_x power loss
9.	D2 Pd	0.0 W	Diode	Diode power dissipation
10.	D3 Pd	0.0 W	Diode	Diode power dissipation
11.	IC Pd	1.529 W	IC	IC power dissipation
12.	IC Tj	106.643 degC	IC	IC junction temperature
13.	IC Tolerance	12.0 mV	IC	IC Feedback Tolerance
14.	ICThetaJA	30.5 degC/W	IC	IC junction-to-ambient thermal resistance
15.	Iin Avg	13.009 A	IC	Average input current
16.	L Ipp	22.01 A	Inductor	Peak-to-peak inductor ripple current
17.	L Pd	1.344 W	Inductor	Inductor power dissipation
18.	L1 Irms	17.215 A	Inductor	Inductor ripple current
19.	M1 Irms	14.317 A	Mosfet	MOSFET RMS ripple current
20.	M1 Pd	1.965 W	Mosfet	MOSFET power dissipation
21.	M1 PdCond	292.91 mW	Mosfet	M1 MOSFET conduction losses
22.	M1 PdSw	1.672 W	Mosfet	M1 MOSFET switching losses
23.	M1 Rdson	1.428 mOhm	Mosfet	Drain-Source On-resistance
24.	M1 ThetaJA	31.0 degC/W	Mosfet	MOSFET junction-to-ambient thermal resistance
25.	M1 TjOP	120.929 degC	Mosfet	MOSFET junction temperature
26.	M2 Irms	7.143 A	Mosfet	MOSFET RMS ripple current
27.	M2 Pd	107.58 mW	Mosfet	MOSFET power dissipation
28.	M2 PdCond	86.907 mW	Mosfet	M2 MOSFET conduction losses
29.	M2 PdSw	20.675 mW	Mosfet	M2 MOSFET switching losses
30.	M2 Rdson	1.675 mOhm	Mosfet	Drain-Source On-resistance
31.	M2 ThetaJA	30.0 degC/W	Mosfet	MOSFET junction-to-ambient thermal resistance
32.	M2 TjOP	63.227 degC	Mosfet	MOSFET junction temperature
33.	M3 Irms	16.929 A	Mosfet	MOSFET RMS ripple current
34.	M3 Pd	860.16 mW	Mosfet	M3 MOSFET total power dissipation
35.	M3 PdCond	860.16 mW	Mosfet	M3 MOSFET conduction losses
36.	M3 PdSw	234.95 mW	Mosfet	M3 MOSFET switching losses
37.	M3 ThetaJA	28.0 degC/W	Mosfet	MOSFET junction-to-ambient thermal resistance
38.	M3 TjOP	107.653 degC	Mosfet	MOSFET junction temperature
39.	M4 Pd	0.0 W	Mosfet	M4 MOSFET total power dissipation
40.	Cin Pd	163.41 mW	Power	Input capacitor power dissipation
41.	Cout Pd	155.84 mW	Power	Output capacitor power dissipation
42.	Coutx Pd	2.871 mW	Power	Output capacitor_x power loss
43.	D2 Pd	0.0 W	Power	Diode power dissipation
44.	D3 Pd	0.0 W	Power	Diode power dissipation
45.	IC Pd	1.529 W	Power	IC power dissipation
46.	L Pd	1.344 W	Power	Inductor power dissipation
47.	M1 Pd	1.965 W	Power	MOSFET power dissipation
48.	M1 PdCond	292.91 mW	Power	M1 MOSFET conduction losses
49.	M1 PdSw	1.672 W	Power	M1 MOSFET switching losses
50.	M2 Pd	107.58 mW	Power	MOSFET power dissipation
51.	M2 PdCond	86.907 mW	Power	M2 MOSFET conduction losses
52.	M2 PdSw	20.675 mW	Power	M2 MOSFET switching losses

#	Name	Value	Category	Description
53.	M3 Pd	860.16 mW	Power	M3 MOSFET total power dissipation
54.	M3 PdCond	860.16 mW	Power	M3 MOSFET conduction losses
55.	M3 PdSw	234.95 mW	Power	M3 MOSFET switching losses
56.	M3 Rdson	3.36 mOhm	Power	Drain-Source On-resistance
57.	M4 Pd	0.0 W	Power	M4 MOSFET total power dissipation
58.	Rsense Pd	153.06 mW	Power	LED Current Rsns Power Dissipation
59.	Total Pd	6.283 W	Power	Total Power Dissipation
60.	Rsense Pd	153.06 mW	Resistor	LED Current Rsns Power Dissipation
61.	Cross Freq	3.009 kHz	System Information	Bode plot crossover frequency
62.	Duty Cycle	80.07 %	System Information	Duty cycle
63.	Efficiency	98.39 %	System Information	Steady state efficiency
64.	FootPrint	2.981 k mm ²	System Information	Total Foot Print Area of BOM components
65.	Frequency	99.216 kHz	System Information	Switching frequency
66.	Gain Marg	-22.674 dB	System Information	Bode Plot Gain Margin
67.	Iout	16.0 A	System Information	Iout operating point
68.	Low Freq Gain	59.464 dB	System Information	Gain at 1Hz
69.	Mode	CCM	System Information	Conduction Mode
70.	Operating Topology	Buck	System Information	The current operating topology of the device
71.	Phase Marg	80.836 deg	System Information	Bode Plot Phase Margin
72.	Pout	384.0 W	System Information	Total output power
73.	SW Ipk	91.288 A	System Information	Peak switch current
74.	Vin	30.0 V	System Information	Vin operating point
75.	Vout	24.0 V	System Information	Operational Output Voltage
76.	Vout Actual	23.84 V	System Information	Vout Actual calculated based on selected voltage divider resistors
77.	Vout Tolerance	3.482 %	System Information	Vout Tolerance based on IC Tolerance (no load) and voltage divider resistors if applicable
78.	Vout p-p	516.988 mV	System Information	Peak-to-peak output ripple voltage

Design Inputs

Name	Value	Description
Iout	16.0	Maximum Output Current
VinMax	30.0	Maximum input voltage
VinMin	24.0	Minimum input voltage
Vout	24.0	Output Voltage
base_pn	LM5175	Base Product Number
source	DC	Input Source Type
Ta	60.0	Ambient temperature

WEBENCH® Assembly

Component Testing

Some published data on components in datasheets such as Capacitor ESR and Inductor DC resistance is based on conservative values that will guarantee that the components always exceed the specification. For design purposes it is usually better to work with typical values. Since this data is not always available it is a good practice to measure the Capacitance and ESR values of C_{in} and C_{out} , and the inductance and DC resistance of L1 before assembly of the board. Any large discrepancies in values should be electrically simulated in WEBENCH to check for instabilities and thermally simulated in WebTHERM to make sure critical temperatures are not exceeded.

Soldering Component to Board

If board assembly is done in house it is best to tack down one terminal of a component on the board then solder the other terminal. For surface mount parts with large tabs, such as the DPAK, the tab on the back of the package should be pre-tinned with solder, then tacked into place by one of the pins. To solder the tab down to the board place the iron down on the board while resting against the tab, heating both surfaces simultaneously. Apply light pressure to the top of the plastic case until the solder flows around the part and the part is flush with the PCB. If the solder is not flowing around the board you may need a higher wattage iron (generally 25W to 30W is enough).

Initial Startup of Circuit

It is best to initially power up the board by setting the input supply voltage to the lowest operating input voltage 24.0V and set the input supply's current limit to zero. With the input supply off connect up the input supply to V_{in} and GND. Connect a digital volt meter and a load if needed to set the minimum load of the design from V_{out} and GND. Turn on the input supply and slowly turn up the current limit on the input supply. If the voltage starts to rise on the input supply continue increasing the input supply current limit while watching the output voltage. If the current increases on the input supply, but the voltage remains near zero, then there may be a short or a component misplaced on the board. Power down the board and visually inspect for solder bridges and recheck the diode and capacitor polarities. Once the power supply circuit is operational then more extensive testing may include full load testing, transient load and line tests to compare with simulation results.

Load Testing

The setup is the same as the initial startup, except that an additional digital voltmeter is connected between V_{in} and GND, a load is connected between V_{out} and GND and a current meter is connected in series between V_{out} and the load. The load must be able to handle at least rated output power + 50% (7.5 watts for this design). Ideally the load is supplied in the form of a variable load test unit. It can also be done in the form of suitably large power resistors. When using an oscilloscope to measure waveforms on the prototype board, the ground leads of the oscilloscope probes should be as short as possible and the area of the loop formed by the ground lead should be kept to a minimum. This will help reduce ground lead inductance and eliminate EMI noise that is not actually present in the circuit.

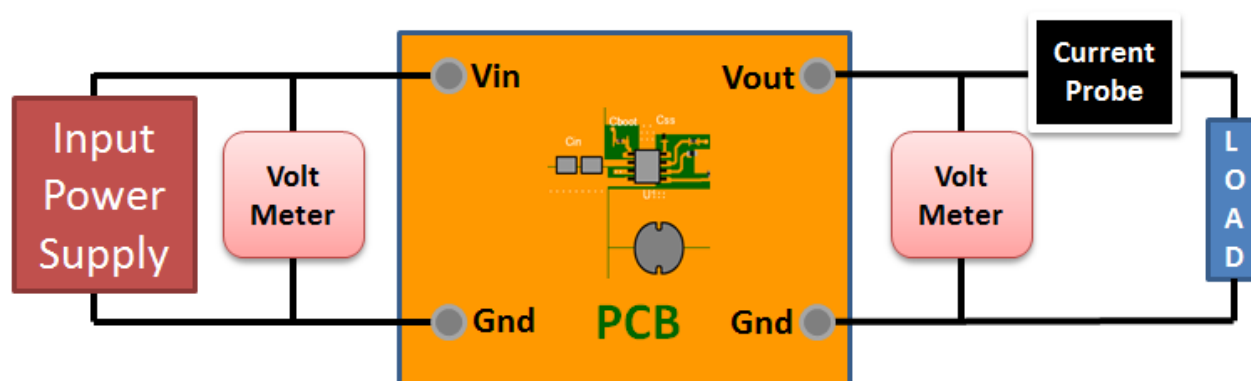

Design Assistance

1. Tip: Snubbers and/or gate resistors may be required to limit the SW1,2 node switching spikes below the IC and FET abs max ratings.
2. Tip: Slope Capacitor: smaller slope capacitors provide better transition region behavior.
3. Master key : B9C964572EBB957B[v1]
4. **LM5175** Product Folder : <http://www.ti.com/product/LM5175> : contains the data sheet and other resources.

Important Notice and Disclaimer

TI provides technical and reliability data (including datasheets), design resources (including reference designs), application or other design advice, web tools, safety information, and other resources AS IS and with all faults, and disclaims all warranties. These resources are intended for skilled developers designing with TI products. You are solely responsible for (1) selecting the appropriate TI products for your application, (2) designing, validating and testing your application, and (3) ensuring your application meets applicable standards, and any other safety, security, or other requirements.

These resources are subject to change without notice. TI grants you permission to use these resources only for development of an application that uses the TI products described in the resource. Other reproduction and display of these resources is prohibited. No license is granted to any other TI intellectual property right or to any third party intellectual property right. TI disclaims responsibility for, and you will fully indemnify TI and its representatives against, any claims, damages, costs, losses, and liabilities arising out of your use of these resources.

Providing these resources does not expand or otherwise alter TI's applicable Terms of Sale or other applicable terms available either on ti.com or provided in conjunction with TI products.