



# IC RF Test Report

**APPLICANT** : Texas Instruments Incorporated  
**EQUIPMENT** : WiFi and Bluetooth Module  
**BRAND NAME** : Texas Instruments  
**MODEL NAME** : WL18MODGI  
**IC** : 451I-WL18DBMOD  
**STANDARD** : IC RSS-247 issue 1

The product was received on Oct. 09, 2014 and testing was completed on Jun. 15, 2016. We, SPORTON INTERNATIONAL INC., would like to declare that the tested sample has been evaluated in accordance with the test procedures and has been in compliance with the applicable technical standards.

The test results in this report apply exclusively to the tested model / sample. Without written approval of SPORTON INTERNATIONAL INC., the test report shall not be reproduced except in full.

Reviewed by: Joseph Lin / Supervisor

Approved by: Jones Tsai / Manager



Testing Laboratory  
1190

## SPORTON INTERNATIONAL INC.

No. 52, Hwa Ya 1<sup>st</sup> Rd., Hwa Ya Technology Park, Kwei-Shan Hsiang, Tao Yuan Hsien, Taiwan, R.O.C.



# TABLE OF CONTENTS

**REVISION HISTORY** ..... 3

**SUMMARY OF TEST RESULT** ..... 4

**1 GENERAL DESCRIPTION** ..... 5

    1.1 Applicant ..... 5

    1.2 Manufacturer ..... 5

    1.3 Feature of Equipment Under Test ..... 5

    1.4 Product Specification of Equipment Under Test ..... 6

    1.5 Modification of EUT ..... 7

    1.6 Testing Location ..... 7

    1.7 Applicable Standards ..... 8

**2 TEST CONFIGURATION OF EQUIPMENT UNDER TEST** ..... 9

    2.1 Carrier Frequency and Channel ..... 10

    2.2 Pre-Scanned RF Power ..... 11

    2.3 Test Mode ..... 14

    2.4 Connection Diagram of Test System ..... 16

    2.5 Support Unit used in test configuration and system ..... 17

    2.6 EUT Operation Test Setup ..... 17

    2.7 Measurement Results Explanation Example ..... 17

**3 TEST RESULT** ..... 18

    3.1 26dB & 99% Bandwidth Measurement ..... 18

    3.2 Maximum Conducted Output Power Measurement ..... 20

    3.3 Power Spectral Density Measurement ..... 22

    3.4 Unwanted Emissions Measurement ..... 26

    3.5 AC Conducted Emission Measurement ..... 59

    3.6 Frequency Stability Measurement ..... 63

    3.7 Automatically Discontinue Transmission ..... 64

    3.8 Antenna Requirements ..... 65

**4 LIST OF MEASURING EQUIPMENT** ..... 66

**5 UNCERTAINTY OF EVALUATION** ..... 67

**APPENDIX A. TEST RESULT OF CONDUCTED TEST RESULTS**

**APPENDIX B. TEST RESULT OF RADIATED TEST RESULTS**

**APPENDIX C. SETUP PHOTOGRAPHS**



## REVISION HISTORY

REPORT NO.	VERSION	DESCRIPTION	ISSUED DATE
CR651030D	Rev. 01	Initial issue of report	Aug. 16, 2016



### SUMMARY OF TEST RESULT

Report Section	IC Rule	Description	Limit	Result	Remark
3.1	RSS-247 Section 6	26dB & 99% Bandwidth	-	Pass	-
3.2	RSS-247 Section 6	Maximum Conducted Output Power	IC RSS-247 Section 6 Limit	Pass	-
3.3	RSS-247 Section 6	Power Spectral Density	IC RSS-247 Section 6 Limit	Pass	-
3.4	RSS-247 Section 6	Unwanted Emissions	$\leq -17, -27$ dBm (depend on band)&15.209(a)	Pass	Under limit 0.78 dB at 5470.000 MHz
3.5	RSS-Gen 8.8	AC Conducted Emission	15.207(a)	Pass	Under limit 3.50 dB at 19.918 MHz
3.6	-	Frequency Stability	Within Operation Band	Pass	-
3.7	RSS-247 6.4(2)	Automatically Discontinue Transmission	Discontinue Transmission	Pass	-
3.8	N/A	Antenna Requirement	N/A	Pass	-



# 1 General Description

## 1.1 Applicant

**Texas Instruments Incorporated**  
12500 TI Boulevard, M/S 8751, Dallas, TX 75243, USA

## 1.2 Manufacturer

**Jorjin Technologies Inc**  
17F, No. 239, Sec. 1, Datong Rd., Xizhi Dist., New Taipei City 221, Taiwan

## 1.3 Feature of Equipment Under Test

Product Feature	
Equipment	WiFi and Bluetooth Module
Brand Name	Texas Instruments
Model Name	WL18MODGI
IC	4511-WL18DBMOD
EUT supports Radios application	WLAN 11a/b/g/n HT20/HT40 Bluetooth v4.0 EDR/LE
HW Version	WG7837-T0B
EUT Stage	Identical Prototype

**Remark:** The above EUT's information was declared by manufacturer. Please refer to the specifications or user's manual for more detailed description.



### 1.4 Product Specification of Equipment Under Test

Product Specification subjective to this standard	
<b>Tx/Rx Channel Frequency Range</b>	5180 MHz ~ 5240 MHz 5260 MHz ~ 5320 MHz 5500 MHz ~ 5580 MHz 5660 MHz ~ 5700 MHz
<b>Maximum Output Power</b>	<b>Ant. 1:</b> <b>&lt;5180 MHz ~ 5240 MHz&gt;</b> 802.11a : 15.58 dBm / 0.0361 W 802.11n HT20 : 15.71 dBm / 0.0372 W 802.11n HT40 : 16.60 dBm / 0.0457 W <b>&lt;5260 MHz ~ 5320 MHz&gt;</b> 802.11a : 13.20 dBm / 0.0209 W 802.11n HT20 : 13.27 dBm / 0.0212 W 802.11n HT40 : 16.86 dBm / 0.0485 W <b>&lt;5500 MHz ~ 5580 MHz and 5660 MHz ~ 5700 MHz&gt;</b> 802.11a : 17.50 dBm / 0.0562 W 802.11n HT20 : 17.24 dBm / 0.0530 W 802.11n HT40 : 15.78 dBm / 0.0378 W <b>Ant. 2:</b> <b>&lt;5180 MHz ~ 5240 MHz&gt;</b> 802.11a : 15.82 dBm / 0.0382 W 802.11n HT20 : 15.54 dBm / 0.0358 W 802.11n HT40 : 16.98 dBm / 0.0499 W <b>&lt;5260 MHz ~ 5320 MHz&gt;</b> 802.11a : 13.48 dBm / 0.0223 W 802.11n HT20 : 13.87 dBm / 0.0244 W 802.11n HT40 : 17.20 dBm / 0.0525 W <b>&lt;5500 MHz ~ 5580 MHz and 5660 MHz ~ 5700 MHz&gt;</b> 802.11a : 18.44 dBm / 0.0698 W 802.11n HT20 : 17.52 dBm / 0.0565 W 802.11n HT40 : 16.74 dBm / 0.0472 W
<b>99% Occupied Bandwidth</b>	802.11a : 19.05 MHz 802.11n HT20 : 18.85 MHz 802.11n HT40 : 36.50 MHz
<b>Type of Modulation</b>	802.11a/n : OFDM (BPSK / QPSK / 16QAM / 64QAM)

Antenna Information			
Antenna Type	Brand	2.4GHz~2.5GHz	4.9GHz~5.8GHz
PCB	Ethertronics	-0.6	4.5
Dipole	LSR	2	2
PCB	Laird	2	4
Chip	Pulse	3.2	4.2
PIFA	LSR	2	3
Chip	TDK	2.4	3.96



### 1.5 Modification of EUT

No modifications are made to the EUT during all test items.

### 1.6 Testing Location

Sporton Lab is accredited to ISO 17025 by Taiwan Accreditation Foundation (TAF code : 1190) and the FCC designation No. TW1022 under the FCC 2.948(e) by Mutual Recognition Agreement (MRA) in FCC Test.

<b>Test Site</b>	SPORTON INTERNATIONAL INC.	
<b>Test Site Location</b>	No. 52, Hwa Ya 1 <sup>st</sup> Rd., Hwa Ya Technology Park, Kwei-Shan Hsiang, Tao Yuan Hsien, Taiwan, R.O.C. TEL: +886-3-327-3456 FAX: +886-3-328-4978	
<b>Test Site No.</b>	<b>Sporton Site No.</b>	
	TH02-HY	CO05-HY

**Note:** The test site complies with ANSI C63.4 2014 requirement.

<b>Test Site</b>	SPORTON INTERNATIONAL INC.	
<b>Test Site Location</b>	No. 52, Hwa Ya 1 <sup>st</sup> Rd., Hwa Ya Technology Park, Kwei-Shan Hsiang, Tao Yuan Hsien, Taiwan, R.O.C. TEL: +886-3-327-3456 FAX: +886-3-328-4978	
<b>Test Site No.</b>	<b>Sporton Site No.</b>	<b>IC Registration No.</b>
	03CH12-HY	4086H-3

**Note:** The test site complies with ANSI C63.4 2014 requirement.



## 1.7 Applicable Standards

According to the specifications of the manufacturer, the EUT must comply with the requirements of the following standards:

- ♦ FCC Part 15 Subpart E
- ♦ FCC KDB 789033 D02 General UNII Test Procedures New Rules v01r02
- ♦ FCC KDB 662911 D01 Multiple Transmitter Output v02r01.
- ♦ ANSI C63.10-2013
- ♦ IC RSS-247 Issued 1
- ♦ IC RSS-Gen Issue 4

**Remark:** All test items were verified and recorded according to the standards and without any deviation during the test.





## **2 Test Configuration of Equipment Under Test**

The EUT has been associated with peripherals and configuration operated in a manner tended to maximize its emission characteristics in a typical application. Frequency range investigated: conducted emission (150 kHz to 30 MHz) and radiated emission (9 kHz to the 10th harmonic of the highest fundamental frequency or to 40 GHz, whichever is lower). For radiated measurement, pre-scanned in three orthogonal panels, X, Y, Z. The worst cases (X plane) were recorded in this report.

The final configuration from all the combinations and the worst-case data rates were investigated by measuring the maximum power across all the data rates and modulation modes under section 2.2.

Based on the worst configuration found above, the RF power setting is set individually to meet FCC compliance limit for the final conducted and radiated tests shown in section 2.3.



## 2.1 Carrier Frequency and Channel

Frequency Band	Channel	Freq. (MHz)	Channel	Freq. (MHz)
5150-5250 MHz Band 1 (U-NII-1)	36	5180	44	5220
	<b>38</b>	<b>5190</b>	<b>46</b>	<b>5230</b>
	40	5200	48	5240

Frequency Band	Channel	Freq. (MHz)	Channel	Freq. (MHz)
5250-5350 MHz Band 2 (U-NII-2A)	52	5260	60	5300
	<b>54</b>	<b>5270</b>	<b>62</b>	<b>5310</b>
	56	5280	64	5320

Frequency Band	Channel	Freq. (MHz)	Channel	Freq. (MHz)
5470-5600 MHz and 5650-5725 MHz Band 3 (U-NII-2C)	100	5500	116	5580
	<b>102</b>	<b>5510</b>	132	5660
	104	5520	<b>134</b>	<b>5670</b>
	108	5540	136	5680
	<b>110</b>	<b>5550</b>	140	5700
	112	5560		

**Note:** The above Frequency and Channel in boldface were 802.11n HT40.



## 2.2 Pre-Scanned RF Power

Preliminary tests were performed in different data rate and data rate associated with the highest power were chosen for full test in the following tables. Final Output Power equals to Measured Output Power adds the duty factor.

<Ant. 1>

5GHz 802.11a mode			
Data Rate (MHz)	6M bps		
Channel	36	44	48
Frequency (MHz)	5180	5220	5240
Average Power (dBm)	15.54	15.58	15.40
Channel	52	60	64
Frequency (MHz)	5260	5300	5320
Average Power (dBm)	13.20	12.94	12.98
Channel	100	116	140
Frequency (MHz)	5500	5580	5700
Average Power (dBm)	14.30	17.50	11.82

5GHz 802.11n HT20 mode			
Data Rate (MHz)	MCS0		
Channel	36	44	48
Frequency (MHz)	5180	5220	5240
Average Power (dBm)	15.71	15.35	15.28
Channel	52	60	64
Frequency (MHz)	5260	5300	5320
Average Power (dBm)	13.12	13.27	12.79
Channel	100	116	140
Frequency (MHz)	5500	5580	5700
Average Power (dBm)	14.06	17.24	11.76



5GHz 802.11n HT40 mode			
Data Rate (MHz)	MCS0		
Channel	38	46	
Frequency (MHz)	5190	5230	
Average Power (dBm)	11.48	16.60	
Channel	54	62	
Frequency (MHz)	5270	5310	
Average Power (dBm)	16.86	11.80	
Channel	102	110	134
Frequency (MHz)	5510	5550	5670
Average Power (dBm)	10.43	15.78	12.56

<Ant. 2>

5GHz 802.11a mode			
Data Rate (MHz)	6M bps		
Channel	36	44	48
Frequency (MHz)	5180	5220	5240
Average Power (dBm)	15.71	15.82	15.56
Channel	52	60	64
Frequency (MHz)	5260	5300	5320
Average Power (dBm)	13.30	13.48	13.28
Channel	100	116	140
Frequency (MHz)	5500	5580	5700
Average Power (dBm)	14.52	18.44	11.94



5GHz 802.11n HT20 mode			
Data Rate (MHz)	MCS0		
Channel	36	44	48
Frequency (MHz)	5180	5220	5240
Average Power (dBm)	15.54	15.53	15.48
Channel	52	60	64
Frequency (MHz)	5260	5300	5320
Average Power (dBm)	13.44	13.87	13.37
Channel	100	116	140
Frequency (MHz)	5500	5580	5700
Average Power (dBm)	14.93	17.52	12.19

5GHz 802.11n HT40 mode			
Data Rate (MHz)	MCS0		
Channel	38	46	
Frequency (MHz)	5190	5230	
Average Power (dBm)	11.76	16.98	
Channel	54	62	
Frequency (MHz)	5270	5310	
Average Power (dBm)	17.20	12.22	
Channel	102	110	134
Frequency (MHz)	5510	5550	5670
Average Power (dBm)	11.30	16.74	12.83



### 2.3 Test Mode

Final results of test modes, data rates and test channels are shown as following table.

Test Cases				
	Test Items	Mode	Data rate	Test Channel
Conducted TCs	26dB and 99% BW Power Spectral Density	802.11a	6 Mbps	L/M/H
		802.11n HT20	MCS0	L/M/H
		802.11n HT40	MCS0	L/M/H
	Output Power	802.11a	6 Mbps	L/M/H
		802.11n HT20	MCS0	L/M/H
		802.11n HT40	MCS0	L/M/H
	Frequency Stability	802.11a	6 Mbps	L/M/H
		802.11n HT20	MCS0	L/M/H
		802.11n HT40	MCS0	L/M/H
Radiated TCs	Radiated Band Edge	802.11a	6 Mbps	L/M/H
	Radiated Spurious Emission	802.11a	6 Mbps	L/M/H
AC Conducted Emission	Mode 1 : WLAN (5GHz) Link + Bluetooth Link + Adapter			
<b>Remark:</b> The worst case of conducted emission is mode 1; only the test data of it was reported.				



Ch. #		Band I : 5150-5250 MHz	Band II : 5250-5350 MHz	Band III : 5470-5600 MHz and 5650-5725MHz
		802.11a	802.11a	802.11a
L	Low	36	52	100
M	Middle	44	60	116
H	High	48	64	140

Ch. #		Band I : 5150-5250 MHz	Band II : 5250-5350 MHz	Band III : 5470-5600 MHz and 5650-5725MHz
		802.11n HT20	802.11n HT20	802.11n HT20
L	Low	36	52	100
M	Middle	44	60	116
H	High	48	64	140

Ch. #		Band I : 5150-5250 MHz	Band II : 5250-5350 MHz	Band III : 5470-5600 MHz and 5650-5725MHz
		802.11n HT40	802.11n HT40	802.11n HT40
L	Low	38	54	102
M	Middle	-	-	110
H	High	46	62	134

## 2.4 Connection Diagram of Test System

<WLAN Tx Mode>

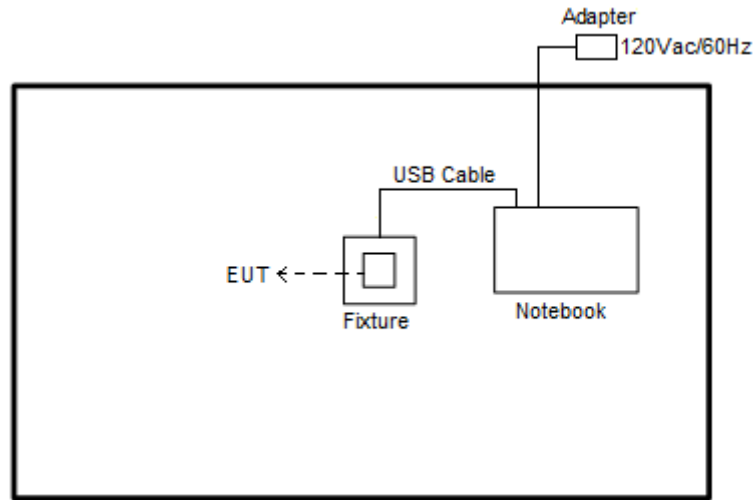

<AC Conducted Emission Mode>

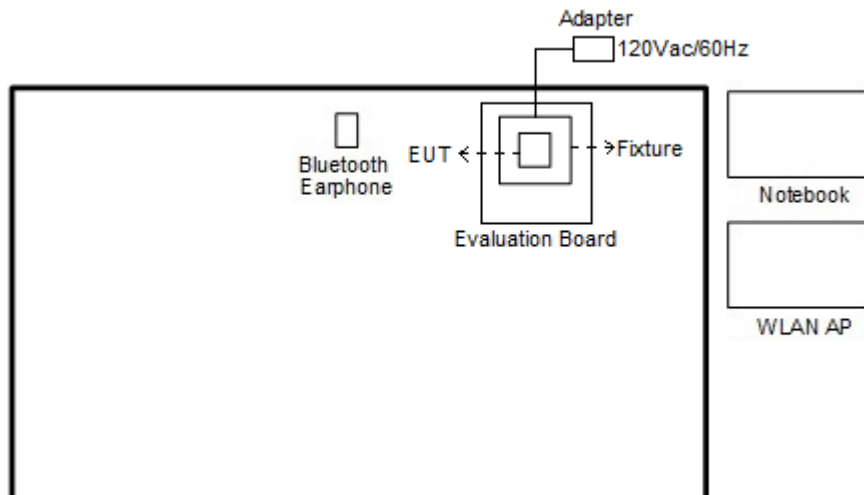





## 2.5 Support Unit used in test configuration and system

Item	Equipment	Trade Name	Model Name	FCC ID	Data Cable	Power Cord
1.	WLAN AP	D-Link	DIR-628	KA2DIR628A2	N/A	Unshielded, 1.8 m
2.	Notebook	DELL	Latitude E6320	FCC DoC/ Contains FCC ID: QDS-BRCM1054	N/A	AC I/P: Unshielded, 1.2 m DC O/P: Shielded, 1.8 m
3.	Notebook	Lenovo	M490S	FCC DoC	N/A	AC I/P: Unshielded, 1.2 m DC O/P: Shielded, 1.8 m
4.	Bluetooth Earphone	Sony Ericsson	MW600	PY7DDA-2029	N/A	N/A
5.	Fixture	N/A	N/A	N/A	N/A	N/A
6.	Evaluation board	N/A	WG1300BE00	N/A	N/A	N/A

## 2.6 EUT Operation Test Setup

For WLAN function, programmed RF utility, "RTTT Tool" installed in the notebook make the EUT provide functions like channel selection and power level for continuous transmitting and receiving signals.

## 2.7 Measurement Results Explanation Example

For all conducted test items:

The offset level is set in the spectrum analyzer to compensate the RF cable loss and attenuator factor between EUT conducted output port and spectrum analyzer. With the offset compensation, the spectrum analyzer reading level is exactly the EUT RF output level.

Example :

The spectrum analyzer offset is derived from RF cable loss and attenuator factor.

*Offset = RF cable loss + attenuator factor.*

Following shows an offset computation example with cable loss 4.2 dB and 10dB attenuator.

$$\begin{aligned} \text{Offset(dB)} &= \text{RF cable loss(dB)} + \text{attenuator factor(dB)}. \\ &= 4.2 + 10 = 14.2 \text{ (dB)} \end{aligned}$$

### 3 Test Result

#### 3.1 26dB & 99% Bandwidth Measurement

##### 3.1.1 Description of 26dB & 99% Occupied Bandwidth

This section is for reporting purpose only.

There is no restriction limits for bandwidth.

##### 3.1.2 Measuring Instruments

The measuring equipment is listed in the section 4 of this test report.

##### 3.1.3 Test Procedures

1. The testing follows FCC KDB 789033 D02 General UNII Test Procedures New Rules v01r02. Section C) Emission bandwidth
2. Set RBW = approximately 1% of the emission bandwidth.
3. Set the VBW > RBW.
4. Detector = Peak.
5. Trace mode = max hold
6. Measure the maximum width of the emission that is 26 dB down from the peak of the emission. Compare this with the RBW setting of the analyzer. Readjust RBW and repeat measurement as needed until the RBW/EBW ratio is approximately 1%.
7. For 99% Bandwidth Measurement, the spectrum analyzer's resolution bandwidth (RBW) is set 1MHz and set the Video bandwidth (VBW)  $\geq 3 * RBW$ .
8. Measure and record the results in the test report.

##### 3.1.4 Test Setup

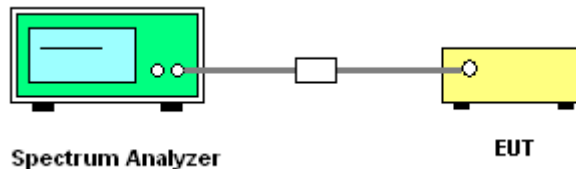



### 3.1.5 Test Result of 26dB & 99% Occupied Bandwidth

Please refer to Appendix A.

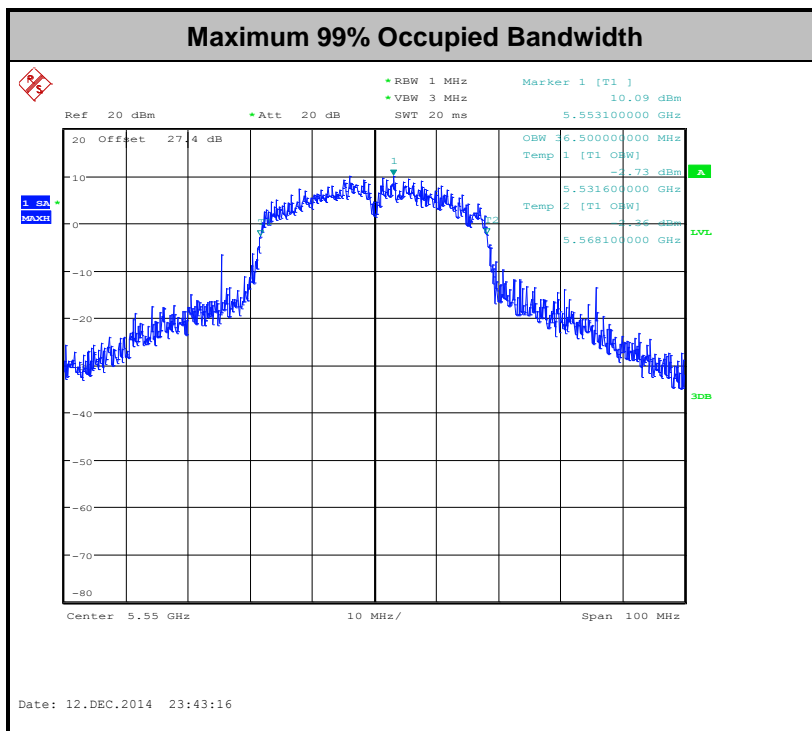
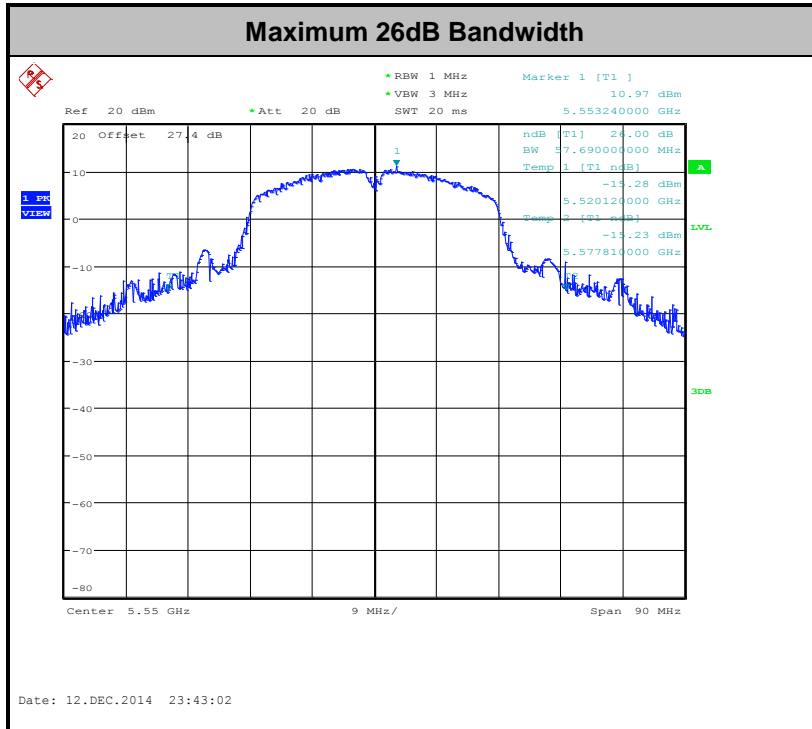



## 3.2 Maximum Conducted Output Power Measurement

### 3.2.1 Limit of Maximum Conducted Output Power

#### <IC RSS-210 Annex 9>

For the 5.15–5.25 GHz band, the maximum e.i.r.p. shall not exceed 200 mW or  $10 + 10 \log_{10} B$ , dBm, whichever power is less. B is the 99% emission bandwidth in MHz.

For the 5.25–5.35 GHz band, the maximum conducted output power shall not exceed 250 mW or  $11 + 10 \log_{10} B$ , dBm, whichever power is less.

For the 5.47–5.6 GHz and 5.65–5.725 GHz band, the maximum conducted output power shall not exceed 250 mW or  $11 + 10 \log_{10} B$ , dBm, whichever power is less.

If transmitting antennas of directional gain greater than 6 dBi are used, the peak output power shall be reduced by the amount in dB that the directional gain of the antenna exceeds 6 dBi.

Note that U-NII-2 band, devices with a maximum e.i.r.p. greater than 500 mW shall implement TPC in order to have the capability to operate at least 6 dB below the maximum permitted e.i.r.p. of 1 W.

### 3.2.2 Measuring Instruments

The measuring equipment is listed in the section 4 of this test report.

### 3.2.3 Test Procedures

The testing follows FCC KDB 789033 D02 General UNII Test Procedures New Rules v01r02.

Section C) Emission bandwidth

Method PM (Measurement using an RF average power meter):

1. Measurement is performed using a wideband RF power meter.
2. The EUT is configured to transmit continuously with a consistent duty cycle at its maximum power control level.
3. Measure the average power of the transmitter, and the average power is corrected with duty factor,  $10 \log(1/x)$ , where  $x$  is the duty cycle.

### 3.2.4 Test Setup

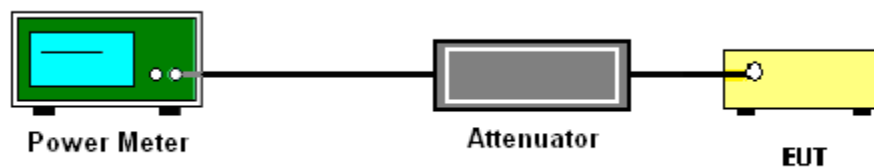

### 3.2.5 Test Result of Maximum Conducted Output Power

Please refer to Appendix A.



### 3.3 Power Spectral Density Measurement

#### 3.3.1 Limit of Power Spectral Density

<IC RSS-210 Annex 9>

For the 5.15–5.25 GHz band, the e.i.r.p. spectral density shall not exceed 10 dBm in any 1.0 MHz band.

For the 5.25–5.35 GHz band, the power spectral density shall not exceed 11 dBm in any 1.0 MHz band.

For the 5.47–5.6 GHz and 5.65–5.725 GHz band, the power spectral density shall not exceed 11 dBm in any 1.0 MHz band.

If transmitting antennas of directional gain greater than 6 dBi are used, the peak output power shall be reduced by the amount in dB that the directional gain of the antenna exceeds 6 dBi.

#### 3.3.2 Measuring Instruments

The measuring equipment is listed in the section 4 of this test report.



### 3.3.3 Test Procedures

The testing follows FCC KDB 789033 D02 General UNII Test Procedures New Rules v01r02.  
Section F) Maximum power spectral density.

#### # Method SA-2 #

(trace averaging across on and off times of the EUT transmissions, followed by duty cycle correction).

1. The testing follows Method SA-2 of FCC KDB 789033 D02 General UNII Test Procedures New Rules v01.
  - Measure the duty cycle.
  - Set span to encompass the entire emission bandwidth (EBW) of the signal.
  - Set RBW = 1 MHz.
  - Set VBW  $\geq$  3 MHz.
  - Number of points in sweep  $\geq$  2 Span / RBW.
  - Sweep time = auto.
  - Detector = RMS
  - Trace average at least 100 traces in power averaging mode.
  - Add  $10 \log(1/x)$ , where x is the duty cycle, to the measured power in order to compute the average power during the actual transmission times. For example, add  $10 \log(1/0.25) = 6$  dB if the duty cycle is 25 percent.
2. The RF output of EUT was connected to the spectrum analyzer by a low loss cable.
3. Each plot has already offset with cable loss, and attenuator loss. Measure the PPSD and record it.
4. For MIMO mode, calculation method follows FCC KDB 662911 D01 Multiple Transmitter Output v02r01.

Method (1): Measure and sum the spectra across the outputs.

The total final Power Spectral Density is from a device with 2 transmitter outputs. The spectrum measurements of the individual outputs are all performed with the same span and number of points, the spectrum value in the first spectral bin of output 1 is summed with that in the first spectral bin of output 2 to obtain the value for the first frequency bin of the summed spectrum.

### 3.3.4 Test Setup

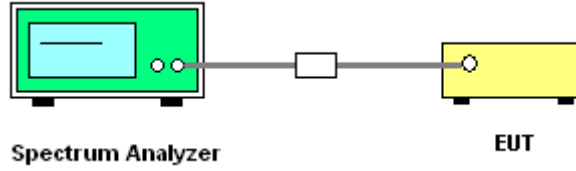





### 3.3.5 Test Result of Power Spectral Density

Please refer to Appendix A.

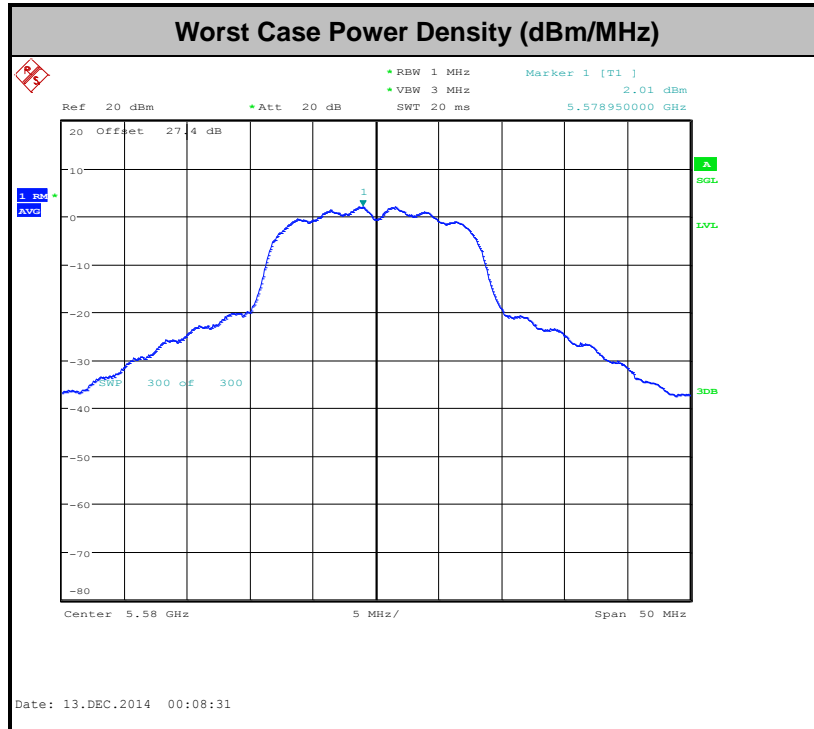



### 3.4 Unwanted Emissions Measurement

This section as specified in FCC Part 15.407(b) is to measure unwanted emissions through radiated measurement for band edge spurious emissions and out of band emissions measurement. The unwanted emissions shall comply with 15.407(b)(1) to (6), and restricted bands per FCC Part15.205.

#### 3.4.1 Limit of Unwanted Emissions

(1) For transmitters operating in the 5150-5250 MHz band: all emissions outside of the 5150-5350 MHz band shall not exceed an EIRP of -27dBm/MHz.

For transmitters operating in the 5250-5350 MHz band: all emissions outside of the 5150-5350 MHz band shall not exceed an EIRP of -27 dBm/MHz. Devices operating in the 5250-5350 MHz band that generate emissions in the 5150-5250 MHz band must meet all applicable technical requirements for operation in the 5150-5250 MHz band (including indoor use) or alternatively meet an out-of-band emission EIRP limit of -27 dBm/MHz in the 5150-5250 MHz band.

For transmitters operating in the 5470-5600 MHz and 5650-5725MHz band: all emissions outside of the 5470-5600 MHz and 5650-5725MHz band shall not exceed an EIRP of -27 dBm/MHz.

(2) Unwanted spurious emissions fallen in restricted bands per FCC Part15.205 shall comply with the general field strength limits set forth in § 15.209 as below table,

Frequency (MHz)	Field Strength (microvolts/meter)	Measurement Distance (meters)
0.009 – 0.490	2400/F(kHz)	300
0.490 – 1.705	24000/F(kHz)	30
1.705 – 30.0	30	30
30 – 88	100	3
88 – 216	150	3
216 - 960	200	3
Above 960	500	3

**Note:** The following formula is used to convert the EIRP to field strength.

$$E = \frac{1000000\sqrt{30P}}{3} \mu\text{V/m, where P is the eirp (Watts)}$$

EIRP (dBm)	Field Strength at 3m (dBμV/m)
-17	78.3
- 27	68.3

(3) KDB789033 D02 v01r02 G)2)c) As specified in 15.407(b), emissions above 1000 MHz that are outside of the restricted bands are subject to a peak emission limit of -27 dBm/MHz (or -17 dBm/MHz as specified in 15.407(b)(4)). However, an out-of-band emission that complies with



both the average and peak limits of 15.209 is not required to satisfy the -27 dBm/MHz or -17 dBm/MHz peak emission limit.

### **3.4.2 Measuring Instruments**

The measuring equipment is listed in the section 4 of this test report.



3.4.3 Test Procedures

1. The testing follows FCC KDB 789033 D02 General UNII Test Procedures New Rules v01r02. Section G) Unwanted emissions measurement.

(1) Procedure for Unwanted Emissions Measurements Below 1000MHz

- RBW = 120 kHz
- VBW = 300 kHz
- Detector = Peak
- Trace mode = max hold

(2) Procedure for Peak Unwanted Emissions Measurements Above 1000 MHz

- RBW = 1 MHz
- VBW ≥ 3 MHz
- Detector = Peak
- Sweep time = auto
- Trace mode = max hold

(3) Procedures for Average Unwanted Emissions Measurements Above 1000MHz

- RBW = 1 MHz
- VBW = 10 Hz, when duty cycle is no less than 98 percent.
- VBW ≥ 1/T, when duty cycle is less than 98 percent where T is the minimum transmission duration over which the transmitter is on and is transmitting at its maximum power control level for the tested mode of operation.

Antenna	Band	Duty Cycle(%)	T(us)	1/T(kHz)	VBW Setting
1	802.11a	93.01	3413.46	0.29	300Hz
1	802.11an20	92.92	3157.05	0.32	1kHz
1	802.11an40	86.61	1554.49	0.64	1kHz
2	802.11a	93.42	3413.46	0.29	300Hz
2	802.11an20	93.4	3173.08	0.32	1kHz
2	802.11an40	86.1	1538.46	0.65	1kHz

- The EUT was placed on a turntable with 0.8 meter for frequency below 1GHz and 1.5 meter for frequency above 1GHz respectively above ground.
- The EUT was set 3 meters from the interference receiving antenna which was mounted on the top of a variable height antenna tower.
- The antenna is a broadband antenna and its height is adjusted between one meter and four meters above ground to find the maximum value of the field strength for both horizontal polarization and vertical polarization of the antenna.
- For each suspected emission, the EUT was arranged to its worst case and then adjust the antenna tower (from 1 m to 4 m) and turntable (from 0 degree to 360 degrees) to find the

maximum reading.

- 6. For testing below 1GHz, if the emission level of the EUT in peak mode was 3 dB lower than the limit specified, then peak values of EUT will be reported, otherwise, the emissions will be repeated one by one using the CISPR quasi-peak method and reported.
- 7. For testing above 1GHz, the emission level of the EUT in peak mode was 20dB lower than average limit (that means the emission level in average mode also complies with the limit in average mode), then peak values of EUT will be reported, otherwise, the emissions will be measured in average mode again and reported.

### 3.4.4 Test Setup

**For Conducted Measurement Setup:**

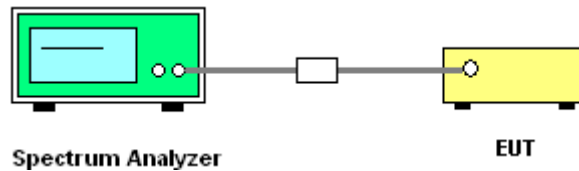

**For radiated emissions below 30MHz**

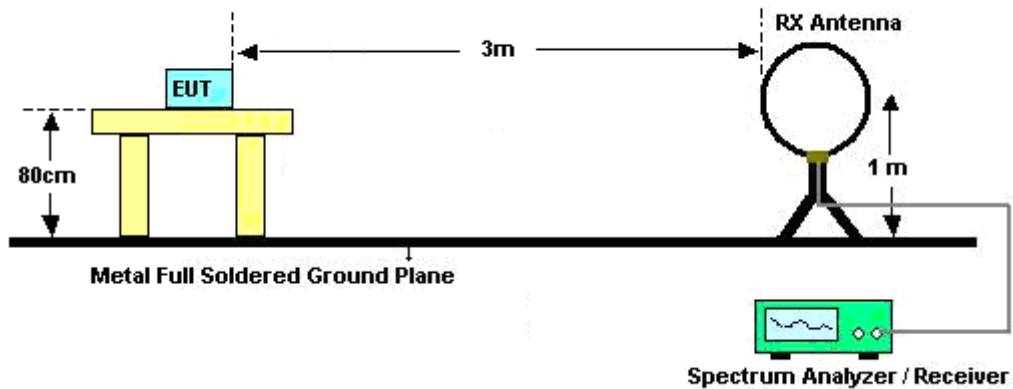

For radiated emissions from 30MHz to 1GHz

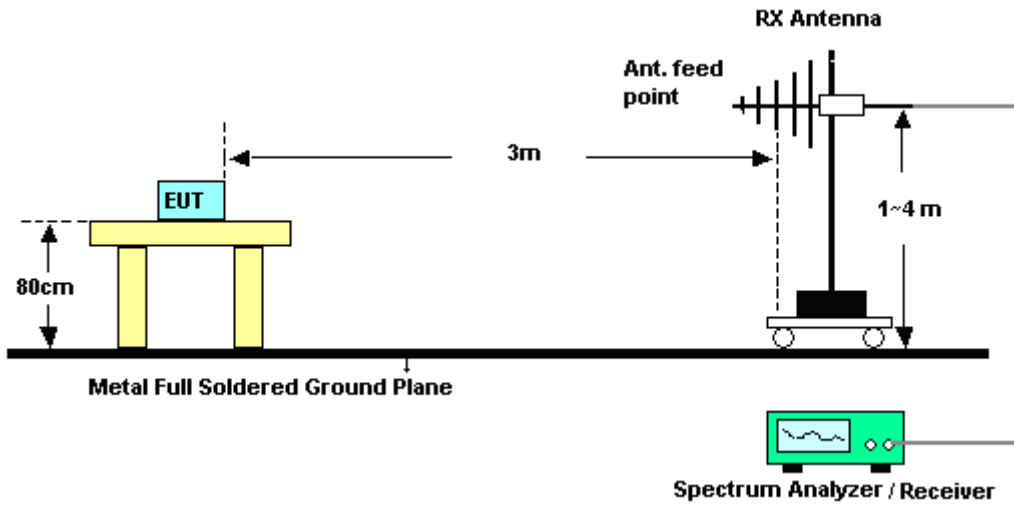

For radiated emissions above 1GHz

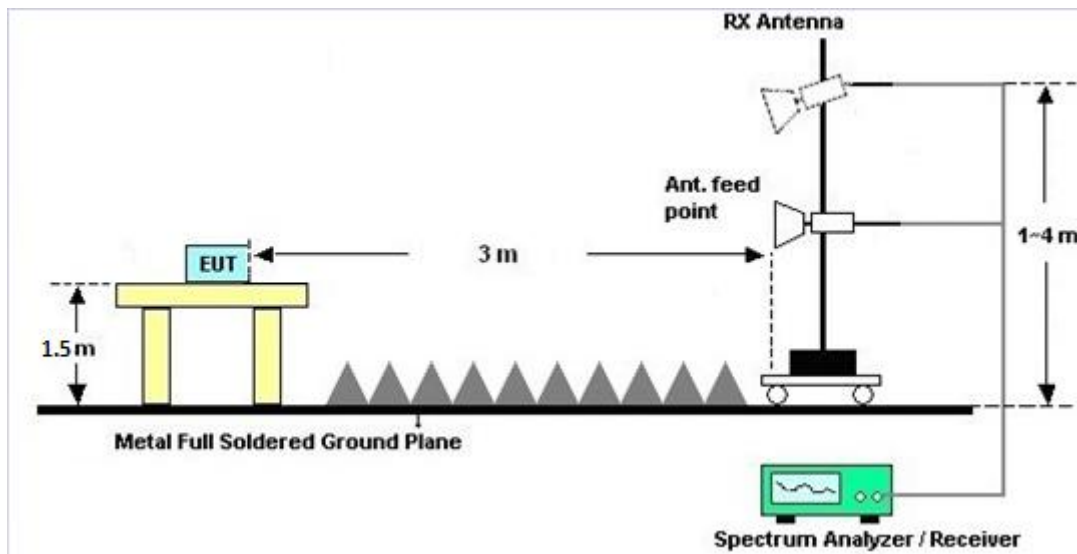



### **3.4.5 Test Results of Radiated Emissions (9 kHz ~ 30 MHz)**

The low frequency, which started from 9 kHz to 30MHz, was pre-scanned and the result which was 20dB lower than the limit line per 15.31(o) was not reported.

### **3.4.6 Test Result of Cabinet Radiated Spurious at Band Edges**

Please refer to Appendix B

### **3.4.7 Test Result of Cabinet Radiated Spurious Emission (30MHz ~ 10<sup>th</sup> Harmonic)**

Please refer to Appendix B.



3.4.8 Test Result of Conducted Spurious at Band Edges in the Restricted Band

5150~5250MHz

WIFI 802.11a (Band Edge @ 3m)

WIFI	Note	Frequency	Level	Over	Limit	Read	Antenna	Cable	Grounding	Peak
Ant.				Limit	Line	Level	Gain	Loss	Factor	Avg
1		( MHz )	( dBμV/m )	( dB )	( dBμV/m )	( dBμV )	( dBi )	( dB )	( dB )	( P/A )
802.11a CH 36 5180MHz		5150	-22.86	-1.66	-21.2	-29.86	4.5	2.5	0	P
		5147.3	-43.02	-1.82	-41.2	-50.02	4.5	2.5	0	A
	*	5181	11.75	-	-	4.75	4.5	2.5	0	P
	*	5181	1.31	-	-	-5.69	4.5	2.5	0	A
802.11a CH 44 5220MHz		5115.2	-40.16	-18.96	-21.2	-47.16	4.5	2.5	0	P
		5117	-50.4	-9.2	-41.2	-57.4	4.5	2.5	0	A
	*	5219	16.2	-	-	9.2	4.5	2.5	0	P
	*	5219	7.74	-	-	0.74	4.5	2.5	0	A
		5367.6	-47.19	-25.99	-21.2	-54.19	4.5	2.5	0	P
		5426.67	-58.07	-16.87	-41.2	-65.07	4.5	2.5	0	A
802.11a CH 48 5240MHz		5135	-41.39	-20.19	-21.2	-48.39	4.5	2.5	0	P
		5135.3	-50.69	-9.49	-41.2	-57.69	4.5	2.5	0	A
	*	5239	16.5	-	-	9.5	4.5	2.5	0	P
	*	5239	7.4	-	-	0.4	4.5	2.5	0	A
2										
802.11a CH 36 5180MHz		5150	-30.54	-9.34	-21.2	-37.54	4.5	2.5	0	P
		5148.2	-48.68	-7.48	-41.2	-55.68	4.5	2.5	0	A
	*	5178	16.18	-	-	9.18	4.5	2.5	0	P
	*	5178	7.44	-	-	0.44	4.5	2.5	0	A
802.11a CH 44 5220MHz		5114.9	-41.27	-20.07	-21.2	-48.27	4.5	2.5	0	P
		5114.9	-51.08	-9.88	-41.2	-58.08	4.5	2.5	0	A
	*	5222	15.99	-	-	8.99	4.5	2.5	0	P
	*	5222	7.87	-	-	0.87	4.5	2.5	0	A
		5425.46	-46.6	-25.4	-21.2	-53.6	4.5	2.5	0	P
		5426.67	-58.48	-17.28	-41.2	-65.48	4.5	2.5	0	A
802.11a CH 48 5240MHz		5134.85	-40.72	-19.52	-21.2	-47.72	4.5	2.5	0	P
		5134.4	-50.49	-9.29	-41.2	-57.49	4.5	2.5	0	A
	*	5241	16.46	-	-	9.46	4.5	2.5	0	P
	*	5241	7.62	-	-	0.62	4.5	2.5	0	A





5150~5250MHz

WIFI 802.11n HT20 (Band Edge @ 3m)

WIFI	Note	Frequency	Level	Over	Limit	Read	Antenna	Cable	Grounding	Peak
Ant.				Limit	Line	Level	Gain	Loss	Factor	Avg
1		( MHz )	( dBμV/m )	( dB )	( dBμV/m )	( dBμV )	( dBi )	( dB )	( dB )	( P/A )
802.11n		5143.55	-26.36	-5.16	-21.2	-33.36	4.5	2.5	0	P
HT20		5150	-48.08	-6.88	-41.2	-55.08	4.5	2.5	0	A
CH 36	*	5181	16.16	-	-	9.16	4.5	2.5	0	P
5180MHz	*	5181	7.16	-	-	0.16	4.5	2.5	0	A
802.11n		5147.9	-39.59	-18.39	-21.2	-46.59	4.5	2.5	0	P
HT20		5116.85	-50.58	-9.38	-41.2	-57.58	4.5	2.5	0	A
CH 44	*	5221	15.81	-	-	8.81	4.5	2.5	0	P
5220MHz	*	5221	7.35	-	-	0.35	4.5	2.5	0	A
802.11n		5134.4	-40.46	-19.26	-21.2	-47.46	4.5	2.5	0	P
HT20		5136.95	-50.71	-9.51	-41.2	-57.71	4.5	2.5	0	A
CH 48	*	5241	16.5	-	-	9.5	4.5	2.5	0	P
5240MHz	*	5241	7.44	-	-	0.44	4.5	2.5	0	A
2										
802.11n		5147.45	-30.13	-8.93	-21.2	-37.13	4.5	2.5	0	P
HT20		5149.55	-48.75	-7.55	-41.2	-55.75	4.5	2.5	0	A
CH 36	*	5178	16.22	-	-	9.22	4.5	2.5	0	P
5180MHz	*	5178	7.58	-	-	0.58	4.5	2.5	0	A
802.11n		5112.95	-39.83	-18.63	-21.2	-46.83	4.5	2.5	0	P
HT20		5114.75	-50.85	-9.65	-41.2	-57.85	4.5	2.5	0	A
CH 44	*	5218	15.39	-	-	8.39	4.5	2.5	0	P
5220MHz	*	5218	7.71	-	-	0.71	4.5	2.5	0	A
802.11n		5134.25	-41.01	-19.81	-21.2	-48.01	4.5	2.5	0	P
HT20		5133.65	-50.74	-9.54	-41.2	-57.74	4.5	2.5	0	A
CH 48	*	5242	16.74	-	-	9.74	4.5	2.5	0	P
5240MHz	*	5242	7.82	-	-	0.82	4.5	2.5	0	A



**5150~5250MHz**

**WIFI 802.11n HT40 (Band Edge @ 3m)**

WIFI	Note	Frequency	Level	Over	Limit	Read	Antenna	Cable	Grounding	Peak
Ant.				Limit	Line	Level	Gain	Loss	Factor	Avg
1		( MHz )	( dBμV/m )	( dB )	( dBμV/m )	( dBμV )	( dBi )	( dB )	( dB )	( P/A )
802.11n HT40 CH 38 5190MHz		5149.7	-32.02	-10.82	-21.2	-39.02	4.5	2.5	0	P
		5149.85	-48.54	-7.34	-41.2	-55.54	4.5	2.5	0	A
	*	5193	7.77	-	-	0.77	4.5	2.5	0	P
	*	5193	-0.82	-	-	-7.82	4.5	2.5	0	A
		5400.05	-48.6	-27.4	-21.2	-55.6	4.5	2.5	0	P
		5395.65	-60.13	-18.93	-41.2	-67.13	4.5	2.5	0	A
802.11n HT40 CH 46 5230MHz		5136.8	-31.73	-10.53	-21.2	-38.73	4.5	2.5	0	P
		5137.4	-50.33	-9.13	-41.2	-57.33	4.5	2.5	0	A
	*	5232	14.33	-	-	7.33	4.5	2.5	0	P
	*	5232	5.35	-	-	-1.65	4.5	2.5	0	A
		5352.53	-43.77	-22.57	-21.2	-50.77	4.5	2.5	0	P
		5350.11	-55.65	-14.45	-41.2	-62.65	4.5	2.5	0	A
<b>2</b>										
802.11n HT40 CH 38 5190MHz		5149.1	-34.44	-13.24	-21.2	-41.44	4.5	2.5	0	P
		5149.55	-47.7	-6.5	-41.2	-54.7	4.5	2.5	0	A
	*	5191	8.14	-	-	1.14	4.5	2.5	0	P
	*	5191	-0.32	-	-	-7.32	4.5	2.5	0	A
		5353.08	-48.72	-27.52	-21.2	-55.72	4.5	2.5	0	P
		5396.75	-59.64	-18.44	-41.2	-66.64	4.5	2.5	0	A
802.11n HT40 CH 46 5230MHz		5136.8	-33.07	-11.87	-21.2	-40.07	4.5	2.5	0	P
		5137.4	-50.8	-9.6	-41.2	-57.8	4.5	2.5	0	A
	*	5232	14.63	-	-	7.63	4.5	2.5	0	P
	*	5232	5.68	-	-	-1.32	4.5	2.5	0	A
		5354.07	-41.9	-20.7	-21.2	-48.9	4.5	2.5	0	P
		5350	-55.13	-13.93	-41.2	-62.13	4.5	2.5	0	A



5250~5350MHz

WIFI 802.11a (Band Edge @ 3m)

WIFI	Note	Frequency	Level	Over	Limit	Read	Antenna	Cable	Grounding	Peak
Ant.				Limit	Line	Level	Gain	Loss	Factor	Avg
1		( MHz )	( dBμV/m )	( dB )	( dBμV/m )	( dBμV )	( dBi )	( dB )	( dB )	( P/A )
802.11a CH 52 5260MHz	*	5261	12.79	-	-	5.79	4.5	2.5	0	P
	*	5261	4.31	-	-	-2.69	4.5	2.5	0	A
		5367.16	-40.55	-19.35	-21.2	-47.55	4.5	2.5	0	P
		5364.85	-51.46	-10.26	-41.2	-58.46	4.5	2.5	0	A
802.11a CH 60 5300MHz		5029.1	-45.84	-24.64	-21.2	-52.84	4.5	2.5	0	P
		5028.05	-56.18	-14.98	-41.2	-63.18	4.5	2.5	0	A
	*	5302	13.13	-	-	6.13	4.5	2.5	0	P
	*	5302	4.51	-	-	-2.49	4.5	2.5	0	A
		5405.11	-42.31	-21.11	-21.2	-49.31	4.5	2.5	0	P
		5405.99	-52.71	-11.51	-41.2	-59.71	4.5	2.5	0	A
802.11a CH 64 5320MHz	*	5322	13.27	-	-	6.27	4.5	2.5	0	P
	*	5322	4.81	-	-	-2.19	4.5	2.5	0	A
		5354.07	-38.38	-17.18	-21.2	-45.38	4.5	2.5	0	P
		5350.99	-50.78	-9.58	-41.2	-57.78	4.5	2.5	0	A
2										
802.11a CH 52 5260MHz	*	5262	13.78	-	-	6.78	4.5	2.5	0	P
	*	5262	4.91	-	-	-2.09	4.5	2.5	0	A
		5363.31	-40.8	-19.6	-21.2	-47.8	4.5	2.5	0	P
		5366.06	-50.79	-9.59	-41.2	-57.79	4.5	2.5	0	A
802.11a CH 60 5300MHz		5028.5	-45.21	-24.01	-21.2	-52.21	4.5	2.5	0	P
		5029.4	-56.38	-15.18	-41.2	-63.38	4.5	2.5	0	A
	*	5298	14.32	-	-	7.32	4.5	2.5	0	P
	*	5298	5	-	-	-2	4.5	2.5	0	A
		5406.1	-41.62	-20.42	-21.2	-48.62	4.5	2.5	0	P
		5405.44	-51.65	-10.45	-41.2	-58.65	4.5	2.5	0	A
802.11a CH 64 5320MHz	*	5319	13.74	-	-	6.74	4.5	2.5	0	P
	*	5319	5.21	-	-	-1.79	4.5	2.5	0	A
		5352.09	-37.08	-15.88	-21.2	-44.08	4.5	2.5	0	P
		5424.69	-51.35	-10.15	-41.2	-58.35	4.5	2.5	0	A



**5250~5350MHz**

**WIFI 802.11n HT20 (Band Edge @ 3m)**

WIFI	Note	Frequency	Level	Over	Limit	Read	Antenna	Cable	Grounding	Peak
Ant.				Limit	Line	Level	Gain	Loss	Factor	Avg
1		( MHz )	( dBμV/m )	( dB )	( dBμV/m )	( dBμV )	( dBi )	( dB )	( dB )	( P/A )
802.11n	*	5260	12.64	-	-	5.64	4.5	2.5	0	P
HT20	*	5260	4.3	-	-	-2.7	4.5	2.5	0	A
CH 52		5365.84	-41.27	-20.07	-21.2	-48.27	4.5	2.5	0	P
5260MHz		5365.62	-51.45	-10.25	-41.2	-58.45	4.5	2.5	0	A
802.11n		5029.55	-46.21	-25.01	-21.2	-53.21	4.5	2.5	0	P
		5027.75	-56.31	-15.11	-41.2	-63.31	4.5	2.5	0	A
HT20	*	5301	12.7	-	-	5.7	4.5	2.5	0	P
CH 60	*	5301	4.61	-	-	-2.39	4.5	2.5	0	A
5300MHz		5400.71	-41.54	-20.34	-21.2	-48.54	4.5	2.5	0	P
		5403.13	-52.6	-11.4	-41.2	-59.6	4.5	2.5	0	A
802.11n	*	5318	12.92	-	-	5.92	4.5	2.5	0	P
HT20	*	5318	4.5	-	-	-2.5	4.5	2.5	0	A
CH 64		5354.51	-38.1	-16.9	-21.2	-45.1	4.5	2.5	0	P
5320MHz		5427.22	-51.76	-10.56	-41.2	-58.76	4.5	2.5	0	A
<b>2</b>										
802.11n	*	5258	13.95	-	-	6.95	4.5	2.5	0	P
HT20	*	5258	4.87	-	-	-2.13	4.5	2.5	0	A
CH 52		5364.96	-40.57	-19.37	-21.2	-47.57	4.5	2.5	0	P
5260MHz		5363.2	-51.21	-10.01	-41.2	-58.21	4.5	2.5	0	A
802.11n		5030	-45.97	-24.77	-21.2	-52.97	4.5	2.5	0	P
		5027.15	-55.98	-14.78	-41.2	-62.98	4.5	2.5	0	A
HT20	*	5298	13.53	-	-	6.53	4.5	2.5	0	P
CH 60	*	5298	5.02	-	-	-1.98	4.5	2.5	0	A
5300MHz		5355.28	-40.18	-18.98	-21.2	-47.18	4.5	2.5	0	P
		5405.44	-52	-10.8	-41.2	-59	4.5	2.5	0	A
802.11n	*	5322	13.41	-	-	6.41	4.5	2.5	0	P
HT20	*	5322	4.96	-	-	-2.04	4.5	2.5	0	A
CH 64		5352.31	-34.37	-13.17	-21.2	-41.37	4.5	2.5	0	P
5320MHz		5425.57	-51.28	-10.08	-41.2	-58.28	4.5	2.5	0	A



**5250~5350MHz**

**WIFI 802.11n HT40 (Band Edge @ 3m)**

WIFI	Note	Frequency	Level	Over	Limit	Read	Antenna	Cable	Grounding	Peak
Ant.				Limit	Line	Level	Gain	Loss	Factor	Avg
1		( MHz )	( dBμV/m )	( dB )	( dBμV/m )	( dBμV )	( dBi )	( dB )	( dB )	( P/A )
802.11n HT40 CH 54 5270MHz		5146.4	-43.55	-22.35	-21.2	-50.55	4.5	2.5	0	P
		5150	-55.16	-13.96	-41.2	-62.16	4.5	2.5	0	A
	*	5268	14.02	-	-	7.02	4.5	2.5	0	P
	*	5268	5.29	-	-	-1.71	4.5	2.5	0	A
		5350.66	-33.26	-12.06	-21.2	-40.26	4.5	2.5	0	P
		5365.29	-50.67	-9.47	-41.2	-57.67	4.5	2.5	0	A
802.11n HT40 CH 62 5310MHz		5114.15	-49.55	-28.35	-21.2	-56.55	4.5	2.5	0	P
		5042.3	-60.8	-19.6	-41.2	-67.8	4.5	2.5	0	A
	*	5308	8.17	-	-	1.17	4.5	2.5	0	P
	*	5308	-0.25	-	-	-7.25	4.5	2.5	0	A
		5350.88	-30.5	-9.3	-21.2	-37.5	4.5	2.5	0	P
		5350	-47.44	-6.24	-41.2	-54.44	4.5	2.5	0	A
<b>2</b>										
802.11n HT40 CH 54 5270MHz		5150	-43.58	-22.38	-21.2	-50.58	4.5	2.5	0	P
		5149.85	-55.39	-14.19	-41.2	-62.39	4.5	2.5	0	A
	*	5272	15.32	-	-	8.32	4.5	2.5	0	P
	*	5272	5.84	-	-	-1.16	4.5	2.5	0	A
		5350.77	-32.84	-11.64	-21.2	-39.84	4.5	2.5	0	P
		5376.18	-50.18	-8.98	-41.2	-57.18	4.5	2.5	0	A
802.11n HT40 CH 62 5310MHz		5126.6	-50.05	-28.85	-21.2	-57.05	4.5	2.5	0	P
		5134.85	-60.88	-19.68	-41.2	-67.88	4.5	2.5	0	A
	*	5312	8.64	-	-	1.64	4.5	2.5	0	P
	*	5312	0.28	-	-	-6.72	4.5	2.5	0	A
		5350.99	-29.84	-8.64	-21.2	-36.84	4.5	2.5	0	P
		5351.1	-45.6	-4.4	-41.2	-52.6	4.5	2.5	0	A



**5470~5725MHz**

**WIFI 802.11a (Band Edge @ 3m)**

WIFI	Note	Frequency	Level	Over	Limit	Read	Antenna	Cable	Grounding	Peak
Ant.				Limit	Line	Level	Gain	Loss	Factor	Avg
1		( MHz )	( dBμV/m )	( dB )	( dBμV/m )	( dBμV )	( dBi )	( dB )	( dB )	( P/A )
802.11a CH 100 5500MHz		5466.64	-32.17	-10.97	-21.2	-39.17	4.5	2.5	0	P
		5469.84	-48.39	-7.19	-41.2	-55.39	4.5	2.5	0	A
	*	5499	14.06	-	-	7.06	4.5	2.5	0	P
	*	5499	5.62	-	-	-1.38	4.5	2.5	0	A
802.11a CH 116 5580MHz		5467.76	-36.47	-15.27	-21.2	-43.47	4.5	2.5	0	P
		5469.84	-50.69	-9.49	-41.2	-57.69	4.5	2.5	0	A
	*	5579	17.2	-	-	10.2	4.5	2.5	0	P
	*	5579	9.81	-	-	2.81	4.5	2.5	0	A
		5726.84	-45.71	-24.51	-21.2	-52.71	4.5	2.5	0	P
		5726.68	-58.82	-17.62	-41.2	-65.82	4.5	2.5	0	A
802.11a CH 140 5700MHz	*	5699	12.59	-	-	5.59	4.5	2.5	0	P
	*	5699	3.87	-	-	-3.13	4.5	2.5	0	A
		5725.32	-32.89	-11.69	-21.2	-39.89	4.5	2.5	0	P
		5725.08	-49.8	-8.6	-41.2	-56.8	4.5	2.5	0	A
<b>2</b>										
802.11a CH 100 5500MHz		5469.52	-30.55	-9.35	-21.2	-37.55	4.5	2.5	0	P
		5470	-48.08	-6.88	-41.2	-55.08	4.5	2.5	0	A
	*	5499	14.68	-	-	7.68	4.5	2.5	0	P
	*	5499	6.49	-	-	-0.51	4.5	2.5	0	A
802.11a CH 116 5580MHz		5469.36	-39.51	-18.31	-21.2	-46.51	4.5	2.5	0	P
		5469.68	-49.17	-7.97	-41.2	-56.17	4.5	2.5	0	A
	*	5581	18.61	-	-	11.61	4.5	2.5	0	P
	*	5581	10.2	-	-	3.2	4.5	2.5	0	A
		5731.24	-46.36	-25.16	-21.2	-53.36	4.5	2.5	0	P
		5729.8	-59.1	-17.9	-41.2	-66.1	4.5	2.5	0	A
802.11a CH 140 5700MHz	*	5701	13.56	-	-	6.56	4.5	2.5	0	P
	*	5701	3.81	-	-	-3.19	4.5	2.5	0	A
		5726.92	-31.34	-10.14	-21.2	-38.34	4.5	2.5	0	P
		5725.24	-50.02	-8.82	-41.2	-57.02	4.5	2.5	0	A



5470~5725MHz

WIFI 802.11n HT20 (Band Edge @ 3m)

WIFI	Note	Frequency	Level	Over	Limit	Read	Antenna	Cable	Grounding	Peak
Ant.				Limit	Line	Level	Gain	Loss	Factor	Avg
1		( MHz )	( dBμV/m )	( dB )	( dBμV/m )	( dBμV )	( dBi )	( dB )	( dB )	( P/A )
802.11n		5468.88	-29.82	-8.62	-21.2	-36.82	4.5	2.5	0	P
HT20		5470	-49.06	-7.86	-41.2	-56.06	4.5	2.5	0	A
CH 100	*	5499	13.85	-	-	6.85	4.5	2.5	0	P
5500MHz	*	5499	5.15	-	-	-1.85	4.5	2.5	0	A
802.11n		5469.2	-40.57	-19.37	-21.2	-47.57	4.5	2.5	0	P
HT20		5470	-50.78	-9.58	-41.2	-57.78	4.5	2.5	0	A
CH 116	*	5581	17.57	-	-	10.57	4.5	2.5	0	P
5580MHz	*	5581	9.1	-	-	2.1	4.5	2.5	0	A
802.11n		5725.64	-45.13	-23.93	-21.2	-52.13	4.5	2.5	0	P
HT20		5730.12	-58.78	-17.58	-41.2	-65.78	4.5	2.5	0	A
CH 140	*	5699	12.03	-	-	5.03	4.5	2.5	0	P
5700MHz	*	5699	3.59	-	-	-3.41	4.5	2.5	0	A
802.11n		5727.32	-31.92	-10.72	-21.2	-38.92	4.5	2.5	0	P
HT20		5725.08	-49.41	-8.21	-41.2	-56.41	4.5	2.5	0	A
CH 140										
2										
802.11n		5469.84	-28.85	-7.65	-21.2	-35.85	4.5	2.5	0	P
HT20		5469.84	-46.83	-5.63	-41.2	-53.83	4.5	2.5	0	A
CH 100	*	5502	14.73	-	-	7.73	4.5	2.5	0	P
5500MHz	*	5502	6.39	-	-	-0.61	4.5	2.5	0	A
802.11n		5470	-40.38	-19.18	-21.2	-47.38	4.5	2.5	0	P
HT20		5469.04	-49.95	-8.75	-41.2	-56.95	4.5	2.5	0	A
CH 116	*	5578	17.98	-	-	10.98	4.5	2.5	0	P
5580MHz	*	5578	9.78	-	-	2.78	4.5	2.5	0	A
802.11n		5730.76	-45.81	-24.61	-21.2	-52.81	4.5	2.5	0	P
HT20		5728.36	-58.89	-17.69	-41.2	-65.89	4.5	2.5	0	A
CH 140	*	5698	12.82	-	-	5.82	4.5	2.5	0	P
5700MHz	*	5698	4.13	-	-	-2.87	4.5	2.5	0	A
802.11n		5729.96	-32.75	-11.55	-21.2	-39.75	4.5	2.5	0	P
HT20		5725.16	-49.56	-8.36	-41.2	-56.56	4.5	2.5	0	A



**5470~5725MHz**

**WIFI 802.11n HT40 (Band Edge @ 3m)**

WIFI	Note	Frequency	Level	Over	Limit	Read	Antenna	Cable	Grounding	Peak
Ant.				Limit	Line	Level	Gain	Loss	Factor	Avg
1		( MHz )	( dBμV/m )	( dB )	( dBμV/m )	( dBμV )	( dBi )	( dB )	( dB )	( P/A )
802.11n		5469.82	-24.71	-3.51	-21.2	-31.71	4.5	2.5	0	P
HT40		5470	-44.25	-3.05	-41.2	-51.25	4.5	2.5	0	A
CH 102	*	5512	6.92	-	-	-0.08	4.5	2.5	0	P
5510MHz	*	5512	-1.57	-	-	-8.57	4.5	2.5	0	A
802.11n		5467.44	-26.45	-5.25	-21.2	-33.45	4.5	2.5	0	P
		5469.84	-43.86	-2.66	-41.2	-50.86	4.5	2.5	0	A
HT40	*	5552	13.6	-	-	6.6	4.5	2.5	0	P
CH 110	*	5552	4.72	-	-	-2.28	4.5	2.5	0	A
5550MHz		5727.8	-46.65	-25.45	-21.2	-53.65	4.5	2.5	0	P
		5751.08	-58.79	-17.59	-41.2	-65.79	4.5	2.5	0	A
802.11n	*	5675	9.84	-	-	2.84	4.5	2.5	0	P
HT40	*	5675	1.33	-	-	-5.67	4.5	2.5	0	A
CH 134		5733.08	-36.55	-15.35	-21.2	-43.55	4.5	2.5	0	P
5670MHz		5746.12	-53.04	-11.84	-41.2	-60.04	4.5	2.5	0	A
2										
802.11n		5469.82	-22.81	-1.61	-21.2	-29.81	4.5	2.5	0	P
HT40		5470	-41.98	-0.78	-41.2	-48.98	4.5	2.5	0	A
CH 102	*	5512	8.22	-	-	1.22	4.5	2.5	0	P
5510MHz	*	5512	-0.54	-	-	-7.54	4.5	2.5	0	A
802.11n		5469.68	-26.14	-4.94	-21.2	-33.14	4.5	2.5	0	P
		5470	-45.08	-3.88	-41.2	-52.08	4.5	2.5	0	A
HT40	*	5548	13.9	-	-	6.9	4.5	2.5	0	P
CH 110	*	5548	5.53	-	-	-1.47	4.5	2.5	0	A
5550MHz		5729.8	-47.74	-26.54	-21.2	-54.74	4.5	2.5	0	P
		5753.48	-58.88	-17.68	-41.2	-65.88	4.5	2.5	0	A
802.11n	*	5668	10.56	-	-	3.56	4.5	2.5	0	P
HT40	*	5668	1.36	-	-	-5.64	4.5	2.5	0	A
CH 134		5733.08	-32.66	-11.46	-21.2	-39.66	4.5	2.5	0	P
5670MHz		5751.24	-52.43	-11.23	-41.2	-59.43	4.5	2.5	0	A





3.4.9 Test Result of Conducted Spurious Emission in the Restricted Band

15E 5150-5250MHz

WIFI 802.11a (Harmonic @ 3m)

WIFI	Note	Frequency	Level	Over	Limit	Read	Antenna	Cable	Grounding	Peak
Ant.				Limit	Line	Level	Gain	Loss	Factor	Avg
1		( MHz )	( dBμV/m )	( dB )	( dBμV/m )	( dBμV )	( dBi )	( dB )	( dB )	( P/A )
802.11a CH 36 5180MHz		120.45	-60.63	-8.93	-51.7	-72.33	4.5	2.5	4.7	P
		161.76	-60.39	-8.69	-51.7	-72.09	4.5	2.5	4.7	P
		220.08	-60.65	-11.45	-49.2	-72.35	4.5	2.5	4.7	P
		533.1	-60.47	-11.27	-49.2	-72.17	4.5	2.5	4.7	P
		694.1	-59.79	-10.59	-49.2	-71.49	4.5	2.5	4.7	P
		839.7	-59.66	-10.46	-49.2	-71.36	4.5	2.5	4.7	P
		10360	-66.68	-45.48	-21.2	-73.68	4.5	2.5	0	P
		15540	-54.34	-33.14	-21.2	-61.34	4.5	2.5	0	P
802.11a CH 44 5220MHz		113.7	-59.25	-7.55	-51.7	-70.95	4.5	2.5	4.7	P
		180.39	-60.99	-9.29	-51.7	-72.69	4.5	2.5	4.7	P
		232.23	-60.84	-11.64	-49.2	-72.54	4.5	2.5	4.7	P
		419	-60.73	-11.53	-49.2	-72.43	4.5	2.5	4.7	P
		602.4	-59.93	-10.73	-49.2	-71.63	4.5	2.5	4.7	P
		794.9	-60.29	-11.09	-49.2	-71.99	4.5	2.5	4.7	P
		10440	-64.26	-43.06	-21.2	-71.26	4.5	2.5	0	P
		15660	-55.17	-33.97	-21.2	-62.17	4.5	2.5	0	P
802.11a CH 48 5240MHz		91.02	-59.55	-7.85	-51.7	-71.25	4.5	2.5	4.7	P
		209.28	-60.95	-9.25	-51.7	-72.65	4.5	2.5	4.7	P
		255.45	-60.02	-10.82	-49.2	-71.72	4.5	2.5	4.7	P
		435.1	-60.7	-11.5	-49.2	-72.4	4.5	2.5	4.7	P
		630.4	-61.43	-12.23	-49.2	-73.13	4.5	2.5	4.7	P
		853.7	-60.57	-11.37	-49.2	-72.27	4.5	2.5	4.7	P
		10480	-63.69	-42.49	-21.2	-70.69	4.5	2.5	0	P
		15720	-54.96	-33.76	-21.2	-61.96	4.5	2.5	0	P



**15E 5150~5250MHz  
WIFI 802.11a (Harmonic @ 3m)**

WIFI	Note	Frequency	Level	Over	Limit	Read	Antenna	Cable	Grounding	Peak
Ant.				Limit	Line	Level	Gain	Loss	Factor	Avg
2		( MHz )	( dBμV/m )	( dB )	( dBμV/m )	( dBμV )	( dBi )	( dB )	( dB )	( P/A )
802.11a CH 36 5180MHz		67.8	-60.37	-5.17	-55.2	-72.07	4.5	2.5	4.7	P
		163.92	-60.63	-8.93	-51.7	-72.33	4.5	2.5	4.7	P
		262.2	-61.25	-12.05	-49.2	-72.95	4.5	2.5	4.7	P
		442.8	-60.32	-11.12	-49.2	-72.02	4.5	2.5	4.7	P
		554.8	-60.2	-11	-49.2	-71.9	4.5	2.5	4.7	P
		829.2	-60.51	-11.31	-49.2	-72.21	4.5	2.5	4.7	P
		10360	-66.19	-44.99	-21.2	-73.19	4.5	2.5	0	P
		15540	-53.86	-32.66	-21.2	-60.86	4.5	2.5	0	P
802.11a CH 44 5220MHz		140.7	-60.37	-8.67	-51.7	-72.07	4.5	2.5	4.7	P
		196.32	-60.91	-9.21	-51.7	-72.61	4.5	2.5	4.7	P
		251.94	-60.54	-11.34	-49.2	-72.24	4.5	2.5	4.7	P
		603.8	-60.39	-11.19	-49.2	-72.09	4.5	2.5	4.7	P
		706.7	-60.43	-11.23	-49.2	-72.13	4.5	2.5	4.7	P
		947.5	-59.42	-10.22	-49.2	-71.12	4.5	2.5	4.7	P
		10440	-64.85	-43.65	-21.2	-71.85	4.5	2.5	0	P
		15660	-53.5	-32.3	-21.2	-60.5	4.5	2.5	0	P
802.11a CH 48 5240MHz		100.47	-60.97	-9.27	-51.7	-72.67	4.5	2.5	4.7	P
		154.47	-61.78	-10.08	-51.7	-73.48	4.5	2.5	4.7	P
		255.99	-61.39	-12.19	-49.2	-73.09	4.5	2.5	4.7	P
		419.7	-60.3	-11.1	-49.2	-72	4.5	2.5	4.7	P
		601.7	-59.58	-10.38	-49.2	-71.28	4.5	2.5	4.7	P
		879.6	-60.57	-11.37	-49.2	-72.27	4.5	2.5	4.7	P
		10480	-64.44	-43.24	-21.2	-71.44	4.5	2.5	0	P
		15720	-55.75	-34.55	-21.2	-62.75	4.5	2.5	0	P



**15E 5150~5250MHz  
WIFI 802.11n HT20 (Harmonic @ 3m)**

WIFI	Note	Frequency	Level	Over	Limit	Read	Antenna	Cable	Grounding	Peak
Ant.				Limit	Line	Level	Gain	Loss	Factor	Avg
1		( MHz )	( dBμV/m )	( dB )	( dBμV/m )	( dBμV )	( dBi )	( dB )	( dB )	( P/A )
802.11n HT20 CH 36 5180MHz		57.54	-62.05	-6.85	-55.2	-73.75	4.5	2.5	4.7	P
		147.18	-62.36	-10.66	-51.7	-74.06	4.5	2.5	4.7	P
		238.44	-63.2	-14	-49.2	-74.9	4.5	2.5	4.7	P
		518.4	-61.66	-12.46	-49.2	-73.36	4.5	2.5	4.7	P
		700.4	-60.64	-11.44	-49.2	-72.34	4.5	2.5	4.7	P
		839	-61.98	-12.78	-49.2	-73.68	4.5	2.5	4.7	P
		10360	-66.26	-45.06	-21.2	-73.26	4.5	2.5	0	P
	15540	-54.03	-32.83	-21.2	-61.03	4.5	2.5	0	P	
802.11n HT20 CH 44 5220MHz		97.5	-60.87	-9.17	-51.7	-72.57	4.5	2.5	4.7	P
		162.3	-60.7	-9	-51.7	-72.4	4.5	2.5	4.7	P
		227.64	-60.75	-11.55	-49.2	-72.45	4.5	2.5	4.7	P
		435.1	-61.06	-11.86	-49.2	-72.76	4.5	2.5	4.7	P
		654.9	-60.74	-11.54	-49.2	-72.44	4.5	2.5	4.7	P
		750.1	-60.79	-11.59	-49.2	-72.49	4.5	2.5	4.7	P
		10440	-63.84	-42.64	-21.2	-70.84	4.5	2.5	0	P
	15660	-54.57	-33.37	-21.2	-61.57	4.5	2.5	0	P	
802.11n HT20 CH 48 5240MHz		110.46	-61	-9.3	-51.7	-72.7	4.5	2.5	4.7	P
		176.61	-61.14	-9.44	-51.7	-72.84	4.5	2.5	4.7	P
		225.75	-60.81	-11.61	-49.2	-72.51	4.5	2.5	4.7	P
		471.5	-59.69	-10.49	-49.2	-71.39	4.5	2.5	4.7	P
		675.2	-58.89	-9.69	-49.2	-70.59	4.5	2.5	4.7	P
		947.5	-59.23	-10.03	-49.2	-70.93	4.5	2.5	4.7	P
		10480	-63.84	-42.64	-21.2	-70.84	4.5	2.5	0	P
	15720	-54.92	-33.72	-21.2	-61.92	4.5	2.5	0	P	



**15E 5150~5250MHz  
WIFI 802.11n HT20 (Harmonic @ 3m)**

WIFI	Note	Frequency	Level	Over	Limit	Read	Antenna	Cable	Grounding	Peak
Ant.				Limit	Line	Level	Gain	Loss	Factor	Avg
2		( MHz )	( dBμV/m )	( dB )	( dBμV/m )	( dBμV )	( dBi )	( dB )	( dB )	( P/A )
802.11n HT20 CH 36 5180MHz		91.02	-60.37	-8.67	-51.7	-72.07	4.5	2.5	4.7	P
		168.78	-60.78	-9.08	-51.7	-72.48	4.5	2.5	4.7	P
		248.97	-61.02	-11.82	-49.2	-72.72	4.5	2.5	4.7	P
		430.9	-60.7	-11.5	-49.2	-72.4	4.5	2.5	4.7	P
		638.8	-60.74	-11.54	-49.2	-72.44	4.5	2.5	4.7	P
		869.1	-59.35	-10.15	-49.2	-71.05	4.5	2.5	4.7	P
		10360	-66.27	-45.07	-21.2	-73.27	4.5	2.5	0	P
	15540	-54.46	-33.26	-21.2	-61.46	4.5	2.5	0	P	
802.11n HT20 CH 44 5220MHz		121.26	-60.99	-9.29	-51.7	-72.69	4.5	2.5	4.7	P
		159.6	-60.63	-8.93	-51.7	-72.33	4.5	2.5	4.7	P
		259.77	-61.36	-12.16	-49.2	-73.06	4.5	2.5	4.7	P
		668.2	-60.96	-11.76	-49.2	-72.66	4.5	2.5	4.7	P
		724.9	-59.05	-9.85	-49.2	-70.75	4.5	2.5	4.7	P
		773.2	-63.36	-14.16	-49.2	-75.06	4.5	2.5	4.7	P
		10440	-64.49	-43.29	-21.2	-71.49	4.5	2.5	0	P
	15660	-54.85	-33.65	-21.2	-61.85	4.5	2.5	0	P	
802.11n HT20 CH 48 5240MHz		140.7	-60.83	-9.13	-51.7	-72.53	4.5	2.5	4.7	P
		237.9	-60.03	-10.83	-49.2	-71.73	4.5	2.5	4.7	P
		265.44	-59.73	-10.53	-49.2	-71.43	4.5	2.5	4.7	P
		595.4	-60.61	-11.41	-49.2	-72.31	4.5	2.5	4.7	P
		673.1	-60.19	-10.99	-49.2	-71.89	4.5	2.5	4.7	P
		874	-58.81	-9.61	-49.2	-70.51	4.5	2.5	4.7	P
		10480	-64.29	-43.09	-21.2	-71.29	4.5	2.5	0	P
	15720	-55.71	-34.51	-21.2	-62.71	4.5	2.5	0	P	



15E 5150~5250MHz
WIFI 802.11n HT40 (Harmonic @ 3m)

Table with 11 columns: WIFI, Note, Frequency, Level, Over, Limit, Read, Antenna, Cable, Grounding, Peak. It contains two main sections of data for 802.11n HT40 channels (CH 38 and CH 46) across various frequencies.



**15E 5150~5250MHz  
WIFI 802.11n HT40 (Harmonic @ 3m)**

WIFI	Note	Frequency	Level	Over	Limit	Read	Antenna	Cable	Grounding	Peak
Ant.				Limit	Line	Level	Gain	Loss	Factor	Avg
2		( MHz )	( dBμV/m )	( dB )	( dBμV/m )	( dBμV )	( dBi )	( dB )	( dB )	( P/A )
802.11n HT40 CH 38 5190MHz		85.89	-60.24	-5.04	-55.2	-71.94	4.5	2.5	4.7	P
		121.26	-60.58	-8.88	-51.7	-72.28	4.5	2.5	4.7	P
		176.88	-60.02	-8.32	-51.7	-71.72	4.5	2.5	4.7	P
		414.1	-60.76	-11.56	-49.2	-72.46	4.5	2.5	4.7	P
		540.8	-60.71	-11.51	-49.2	-72.41	4.5	2.5	4.7	P
		649.3	-60.93	-11.73	-49.2	-72.63	4.5	2.5	4.7	P
		10460	-64.48	-43.28	-21.2	-71.48	4.5	2.5	0	P
	15690	-53.7	-32.5	-21.2	-60.7	4.5	2.5	0	P	
802.11n HT40 CH 46 5230MHz		78.33	-59.69	-4.49	-55.2	-71.39	4.5	2.5	4.7	P
		163.11	-60.6	-8.9	-51.7	-72.3	4.5	2.5	4.7	P
		209.82	-60.92	-9.22	-51.7	-72.62	4.5	2.5	4.7	P
		410.6	-60.47	-11.27	-49.2	-72.17	4.5	2.5	4.7	P
		640.2	-63.01	-13.81	-49.2	-74.71	4.5	2.5	4.7	P
		869.1	-59.79	-10.59	-49.2	-71.49	4.5	2.5	4.7	P
		10460	-64.47	-43.27	-21.2	-71.47	4.5	2.5	0	P
	15690	-54.72	-33.52	-21.2	-61.72	4.5	2.5	0	P	



15E 5250~5350MHz
WIFI 802.11a (Harmonic @ 3m)

Table with 11 columns: WIFI, Note, Frequency, Level, Over, Limit, Read, Antenna, Cable, Grounding, Peak. It contains three main sections of data for different channels (5260MHz, 5300MHz, 5320MHz) with multiple frequency entries per channel.



**15E 5250~5350MHz  
WIFI 802.11a (Harmonic @ 3m)**

WIFI	Note	Frequency	Level	Over	Limit	Read	Antenna	Cable	Grounding	Peak
Ant.				Limit	Line	Level	Gain	Loss	Factor	Avg
2		( MHz )	( dBµV/m )	( dB )	( dBµV/m )	( dBµV )	( dBi )	( dB )	( dB )	( P/A )
802.11a CH 52 5260MHz		145.02	-61.02	-9.32	-51.7	-72.72	4.5	2.5	4.7	P
		176.88	-59.5	-7.8	-51.7	-71.2	4.5	2.5	4.7	P
		234.93	-60.58	-11.38	-49.2	-72.28	4.5	2.5	4.7	P
		510.7	-60.44	-11.24	-49.2	-72.14	4.5	2.5	4.7	P
		722.8	-59.03	-9.83	-49.2	-70.73	4.5	2.5	4.7	P
		912.5	-59.98	-10.78	-49.2	-71.68	4.5	2.5	4.7	P
		10520	-63.62	-42.42	-21.2	-70.62	4.5	2.5	0	P
		15780	-55.5	-34.3	-21.2	-62.5	4.5	2.5	0	P
802.11a CH 60 5300MHz		142.86	-60.1	-8.4	-51.7	-71.8	4.5	2.5	4.7	P
		198.75	-60.73	-9.03	-51.7	-72.43	4.5	2.5	4.7	P
		253.83	-61.06	-11.86	-49.2	-72.76	4.5	2.5	4.7	P
		398.7	-61.27	-12.07	-49.2	-72.97	4.5	2.5	4.7	P
		603.1	-60.67	-11.47	-49.2	-72.37	4.5	2.5	4.7	P
		776.7	-60.45	-11.25	-49.2	-72.15	4.5	2.5	4.7	P
		10600	-64.29	-43.09	-21.2	-71.29	4.5	2.5	0	P
		15900	-56.6	-35.4	-21.2	-63.6	4.5	2.5	0	P
802.11a CH 64 5320MHz		86.7	-60.28	-5.08	-55.2	-71.98	4.5	2.5	4.7	P
		160.68	-60.75	-9.05	-51.7	-72.45	4.5	2.5	4.7	P
		214.95	-60.23	-8.53	-51.7	-71.93	4.5	2.5	4.7	P
		482.7	-60.57	-11.37	-49.2	-72.27	4.5	2.5	4.7	P
		679.4	-60.61	-11.41	-49.2	-72.31	4.5	2.5	4.7	P
		791.4	-60.73	-11.53	-49.2	-72.43	4.5	2.5	4.7	P
		10640	-64.86	-43.66	-21.2	-71.86	4.5	2.5	0	P
		15960	-55.33	-34.13	-21.2	-62.33	4.5	2.5	0	P





**15E 5250~5350MHz**

**WIFI 802.11n HT20 (Harmonic @ 3m)**

WIFI	Note	Frequency	Level	Over	Limit	Read	Antenna	Cable	Grounding	Peak
Ant.				Limit	Line	Level	Gain	Loss	Factor	Avg
1		( MHz )	( dBμV/m )	( dB )	( dBμV/m )	( dBμV )	( dBi )	( dB )	( dB )	( P/A )
802.11n HT20 CH 52 5260MHz		144.48	-60.13	-8.43	-51.7	-71.83	4.5	2.5	4.7	P
		186.33	-60.27	-8.57	-51.7	-71.97	4.5	2.5	4.7	P
		295.68	-60.41	-11.21	-49.2	-72.11	4.5	2.5	4.7	P
		571.6	-60.85	-11.65	-49.2	-72.55	4.5	2.5	4.7	P
		810.3	-59.54	-10.34	-49.2	-71.24	4.5	2.5	4.7	P
		988.8	-60.45	-19.25	-41.2	-72.15	4.5	2.5	4.7	P
		10520	-63.53	-42.33	-21.2	-70.53	4.5	2.5	0	P
	15780	-55.7	-34.5	-21.2	-62.7	4.5	2.5	0	P	
802.11n HT20 CH 60 5300MHz		116.94	-60.39	-8.69	-51.7	-72.09	4.5	2.5	4.7	P
		174.18	-60.24	-8.54	-51.7	-71.94	4.5	2.5	4.7	P
		261.66	-59.48	-10.28	-49.2	-71.18	4.5	2.5	4.7	P
		432.3	-59.57	-10.37	-49.2	-71.27	4.5	2.5	4.7	P
		497.4	-60.47	-11.27	-49.2	-72.17	4.5	2.5	4.7	P
		690.6	-59.57	-10.37	-49.2	-71.27	4.5	2.5	4.7	P
		10600	-65.42	-44.22	-21.2	-72.42	4.5	2.5	0	P
	15900	-56.36	-35.16	-21.2	-63.36	4.5	2.5	0	P	
802.11n HT20 CH 64 5320MHz		151.5	-60.57	-8.87	-51.7	-72.27	4.5	2.5	4.7	P
		193.08	-60.3	-8.6	-51.7	-72	4.5	2.5	4.7	P
		277.32	-59.95	-10.75	-49.2	-71.65	4.5	2.5	4.7	P
		426.7	-60.91	-11.71	-49.2	-72.61	4.5	2.5	4.7	P
		731.2	-60.53	-11.33	-49.2	-72.23	4.5	2.5	4.7	P
		951	-60.39	-11.19	-49.2	-72.09	4.5	2.5	4.7	P
		10640	-64.94	-43.74	-21.2	-71.94	4.5	2.5	0	P
	15960	-55.48	-34.28	-21.2	-62.48	4.5	2.5	0	P	



**15E 5250~5350MHz**

**WIFI 802.11n HT20 (Harmonic @ 3m)**

WIFI	Note	Frequency	Level	Over	Limit	Read	Antenna	Cable	Grounding	Peak
Ant.				Limit	Line	Level	Gain	Loss	Factor	Avg
2		( MHz )	( dBμV/m )	( dB )	( dBμV/m )	( dBμV )	( dBi )	( dB )	( dB )	( P/A )
802.11n HT20 CH 52 5260MHz		88.05	-61.56	-9.86	-51.7	-73.26	4.5	2.5	4.7	P
		162.03	-61.14	-9.44	-51.7	-72.84	4.5	2.5	4.7	P
		203.61	-60.84	-9.14	-51.7	-72.54	4.5	2.5	4.7	P
		399.4	-61.14	-11.94	-49.2	-72.84	4.5	2.5	4.7	P
		533.1	-60.88	-11.68	-49.2	-72.58	4.5	2.5	4.7	P
		766.9	-60.19	-10.99	-49.2	-71.89	4.5	2.5	4.7	P
		10520	-65.87	-44.67	-21.2	-72.87	4.5	2.5	0	P
	15780	-56.99	-35.79	-21.2	-63.99	4.5	2.5	0	P	
802.11n HT20 CH 60 5300MHz		113.7	-60.37	-8.67	-51.7	-72.07	4.5	2.5	4.7	P
		184.17	-60.3	-8.6	-51.7	-72	4.5	2.5	4.7	P
		263.82	-61.1	-11.9	-49.2	-72.8	4.5	2.5	4.7	P
		521.9	-60.57	-11.37	-49.2	-72.27	4.5	2.5	4.7	P
		603.8	-60.73	-11.53	-49.2	-72.43	4.5	2.5	4.7	P
		854.4	-60.65	-11.45	-49.2	-72.35	4.5	2.5	4.7	P
		10600	-65.6	-44.4	-21.2	-72.6	4.5	2.5	0	P
	15900	-55.59	-34.39	-21.2	-62.59	4.5	2.5	0	P	
802.11n HT20 CH 64 5320MHz		140.7	-60.41	-8.71	-51.7	-72.11	4.5	2.5	4.7	P
		179.31	-60.4	-8.7	-51.7	-72.1	4.5	2.5	4.7	P
		262.2	-60.67	-11.47	-49.2	-72.37	4.5	2.5	4.7	P
		488.3	-60.76	-11.56	-49.2	-72.46	4.5	2.5	4.7	P
		685.7	-60.54	-11.34	-49.2	-72.24	4.5	2.5	4.7	P
		792.1	-60.17	-10.97	-49.2	-71.87	4.5	2.5	4.7	P
		10640	-63.82	-42.62	-21.2	-70.82	4.5	2.5	0	P
	15960	-54.74	-33.54	-21.2	-61.74	4.5	2.5	0	P	



15E 5250~5350MHz
WIFI 802.11n HT40 (Harmonic @ 3m)

Table with 11 columns: WIFI, Note, Frequency, Level, Over, Limit, Read, Antenna, Cable, Grounding, Peak. It contains two main sections of data for 802.11n HT40 channels (CH 54 and CH 62) across various frequencies.



**15E 5250~5350MHz  
WIFI 802.11n HT40 (Harmonic @ 3m)**

WIFI	Note	Frequency	Level	Over	Limit	Read	Antenna	Cable	Grounding	Peak
Ant.				Limit	Line	Level	Gain	Loss	Factor	Avg
2		( MHz )	( dBμV/m )	( dB )	( dBμV/m )	( dBμV )	( dBi )	( dB )	( dB )	( P/A )
802.11n HT40 CH 54 5270MHz		131.25	-59.29	-7.59	-51.7	-70.99	4.5	2.5	4.7	P
		168.78	-60.57	-8.87	-51.7	-72.27	4.5	2.5	4.7	P
		244.65	-60.83	-11.63	-49.2	-72.53	4.5	2.5	4.7	P
		565.3	-60.5	-11.3	-49.2	-72.2	4.5	2.5	4.7	P
		694.8	-60.98	-11.78	-49.2	-72.68	4.5	2.5	4.7	P
		909	-60.48	-11.28	-49.2	-72.18	4.5	2.5	4.7	P
		10540	-65.06	-43.86	-21.2	-72.06	4.5	2.5	0	P
802.11n HT40 CH 62 5310MHz		15810	-56.86	-35.66	-21.2	-63.86	4.5	2.5	0	P
		96.15	-60.64	-8.94	-51.7	-72.34	4.5	2.5	4.7	P
		186.06	-60.24	-8.54	-51.7	-71.94	4.5	2.5	4.7	P
		268.14	-60.46	-11.26	-49.2	-72.16	4.5	2.5	4.7	P
		471.5	-59.96	-10.76	-49.2	-71.66	4.5	2.5	4.7	P
		638.8	-60.61	-11.41	-49.2	-72.31	4.5	2.5	4.7	P
		919.5	-60.01	-10.81	-49.2	-71.71	4.5	2.5	4.7	P
	10620	-65	-43.8	-21.2	-72	4.5	2.5	0	P	
	15930	-54.53	-33.33	-21.2	-61.53	4.5	2.5	0	P	



**15E 5470~5725MHz  
WIFI 802.11a (Harmonic @ 3m)**

WIFI	Note	Frequency	Level	Over	Limit	Read	Antenna	Cable	Grounding	Peak
Ant.				Limit	Line	Level	Gain	Loss	Factor	Avg
1		( MHz )	( dBμV/m )	( dB )	( dBμV/m )	( dBμV )	( dBi )	( dB )	( dB )	( P/A )
802.11a CH 100 5500MHz		54.84	-61.34	-6.14	-55.2	-73.04	4.5	2.5	4.7	P
		142.05	-60.87	-9.17	-51.7	-72.57	4.5	2.5	4.7	P
		233.04	-60.95	-11.75	-49.2	-72.65	4.5	2.5	4.7	P
		480.6	-60	-10.8	-49.2	-71.7	4.5	2.5	4.7	P
		623.4	-60.87	-11.67	-49.2	-72.57	4.5	2.5	4.7	P
		900.6	-60.3	-11.1	-49.2	-72	4.5	2.5	4.7	P
		11000	-64.8	-43.6	-21.2	-71.8	4.5	2.5	0	P
		16500	-55.05	-33.85	-21.2	-62.05	4.5	2.5	0	P
802.11a CH 116 5580MHz		62.67	-61.26	-6.06	-55.2	-72.96	4.5	2.5	4.7	P
		156.9	-61.13	-9.43	-51.7	-72.83	4.5	2.5	4.7	P
		216.3	-59.94	-10.74	-49.2	-71.64	4.5	2.5	4.7	P
		524.7	-60.43	-11.23	-49.2	-72.13	4.5	2.5	4.7	P
		671	-60.19	-10.99	-49.2	-71.89	4.5	2.5	4.7	P
		808.9	-60.39	-11.19	-49.2	-72.09	4.5	2.5	4.7	P
		11160	-66.01	-44.81	-21.2	-73.01	4.5	2.5	0	P
		16740	-55.37	-34.17	-21.2	-62.37	4.5	2.5	0	P
802.11a CH 140 5700MHz		85.62	-61	-5.8	-55.2	-72.7	4.5	2.5	4.7	P
		147.99	-61.25	-9.55	-51.7	-72.95	4.5	2.5	4.7	P
		226.02	-60.91	-11.71	-49.2	-72.61	4.5	2.5	4.7	P
		450.5	-60.28	-11.08	-49.2	-71.98	4.5	2.5	4.7	P
		630.4	-59.86	-10.66	-49.2	-71.56	4.5	2.5	4.7	P
		844.6	-59.46	-10.26	-49.2	-71.16	4.5	2.5	4.7	P
		11400	-64.5	-43.3	-21.2	-71.5	4.5	2.5	0	P
		17100	-54.62	-33.42	-21.2	-61.62	4.5	2.5	0	P



**15E 5470~5725MHz  
WIFI 802.11a (Harmonic @ 3m)**

WIFI	Note	Frequency	Level	Over	Limit	Read	Antenna	Cable	Grounding	Peak
Ant.				Limit	Line	Level	Gain	Loss	Factor	Avg
2		( MHz )	( dBμV/m )	( dB )	( dBμV/m )	( dBμV )	( dBi )	( dB )	( dB )	( P/A )
802.11a CH 100 5500MHz		51.6	-60.2	-5	-55.2	-71.9	4.5	2.5	4.7	P
		71.85	-61.06	-5.86	-55.2	-72.76	4.5	2.5	4.7	P
		82.38	-61.23	-6.03	-55.2	-72.93	4.5	2.5	4.7	P
		437.2	-60.38	-11.18	-49.2	-72.08	4.5	2.5	4.7	P
		533.1	-61.14	-11.94	-49.2	-72.84	4.5	2.5	4.7	P
		700.4	-60.76	-11.56	-49.2	-72.46	4.5	2.5	4.7	P
		11000	-65.62	-44.42	-21.2	-72.62	4.5	2.5	0	P
		16500	-54.13	-32.93	-21.2	-61.13	4.5	2.5	0	P
802.11a CH 116 5580MHz		152.85	-60.33	-8.63	-51.7	-72.03	4.5	2.5	4.7	P
		214.68	-60.44	-8.74	-51.7	-72.14	4.5	2.5	4.7	P
		247.35	-59.34	-10.14	-49.2	-71.04	4.5	2.5	4.7	P
		491.1	-60.33	-11.13	-49.2	-72.03	4.5	2.5	4.7	P
		654.9	-60.36	-11.16	-49.2	-72.06	4.5	2.5	4.7	P
		869.8	-61.29	-12.09	-49.2	-72.99	4.5	2.5	4.7	P
		11160	-61.39	-40.19	-21.2	-68.39	4.5	2.5	0	P
		16740	-54.9	-33.7	-21.2	-61.9	4.5	2.5	0	P
802.11a CH 140 5700MHz		226.56	-61.46	-12.26	-49.2	-73.16	4.5	2.5	4.7	P
		256.53	-60.67	-11.47	-49.2	-72.37	4.5	2.5	4.7	P
		296.22	-60.83	-11.63	-49.2	-72.53	4.5	2.5	4.7	P
		351.1	-62.93	-13.73	-49.2	-74.63	4.5	2.5	4.7	P
		569.5	-61.39	-12.19	-49.2	-73.09	4.5	2.5	4.7	P
		988.1	-59.9	-18.7	-41.2	-71.6	4.5	2.5	4.7	P
		11400	-66.67	-45.47	-21.2	-73.67	4.5	2.5	0	P
		17100	-54.68	-33.48	-21.2	-61.68	4.5	2.5	0	P



**15E 5470~5725MHz  
WIFI 802.11n HT20 (Harmonic @ 3m)**

WIFI	Note	Frequency	Level	Over	Limit	Read	Antenna	Cable	Grounding	Peak
Ant.				Limit	Line	Level	Gain	Loss	Factor	Avg
1		( MHz )	( dBμV/m )	( dB )	( dBμV/m )	( dBμV )	( dBi )	( dB )	( dB )	( P/A )
802.11n HT20 CH 100 5500MHz		169.59	-61.03	-9.33	-51.7	-72.73	4.5	2.5	4.7	P
		226.29	-61.37	-12.17	-49.2	-73.07	4.5	2.5	4.7	P
		276.24	-60.58	-11.38	-49.2	-72.28	4.5	2.5	4.7	P
		437.9	-60.84	-11.64	-49.2	-72.54	4.5	2.5	4.7	P
		713	-61.01	-11.81	-49.2	-72.71	4.5	2.5	4.7	P
		902.7	-61.27	-12.07	-49.2	-72.97	4.5	2.5	4.7	P
		11000	-63.12	-41.92	-21.2	-70.12	4.5	2.5	0	P
	16500	-54.17	-32.97	-21.2	-61.17	4.5	2.5	0	P	
802.11n HT20 CH 116 5580MHz		67.53	-58.85	-3.65	-55.2	-70.55	4.5	2.5	4.7	P
		150.15	-58.94	-7.24	-51.7	-70.64	4.5	2.5	4.7	P
		228.99	-60.49	-11.29	-49.2	-72.19	4.5	2.5	4.7	P
		440.7	-60.26	-11.06	-49.2	-71.96	4.5	2.5	4.7	P
		787.9	-60.5	-11.3	-49.2	-72.2	4.5	2.5	4.7	P
		948.2	-59.62	-10.42	-49.2	-71.32	4.5	2.5	4.7	P
		11160	-62.65	-41.45	-21.2	-69.65	4.5	2.5	0	P
	16740	-56.53	-35.33	-21.2	-63.53	4.5	2.5	0	P	
802.11n HT20 CH 140 5700MHz		146.64	-61.43	-9.73	-51.7	-73.13	4.5	2.5	4.7	P
		193.35	-60.69	-8.99	-51.7	-72.39	4.5	2.5	4.7	P
		251.4	-61.43	-12.23	-49.2	-73.13	4.5	2.5	4.7	P
		470.8	-60.57	-11.37	-49.2	-72.27	4.5	2.5	4.7	P
		660.5	-60.17	-10.97	-49.2	-71.87	4.5	2.5	4.7	P
		871.9	-61.04	-11.84	-49.2	-72.74	4.5	2.5	4.7	P
		11400	-64.93	-43.73	-21.2	-71.93	4.5	2.5	0	P
	17100	-55.18	-33.98	-21.2	-62.18	4.5	2.5	0	P	



15E 5470~5725MHz

WIFI 802.11n HT20 (Harmonic @ 3m)

WIFI	Note	Frequency	Level	Over	Limit	Read	Antenna	Cable	Grounding	Peak
Ant.				Limit	Line	Level	Gain	Loss	Factor	Avg
2		( MHz )	( dBμV/m )	( dB )	( dBμV/m )	( dBμV )	( dBi )	( dB )	( dB )	( P/A )
802.11n HT20 CH 100 5500MHz		62.67	-61.43	-6.23	-55.2	-73.13	4.5	2.5	4.7	P
		128.28	-61.36	-9.66	-51.7	-73.06	4.5	2.5	4.7	P
		209.01	-61.48	-9.78	-51.7	-73.18	4.5	2.5	4.7	P
		494.6	-61.11	-11.91	-49.2	-72.81	4.5	2.5	4.7	P
		607.3	-61.19	-11.99	-49.2	-72.89	4.5	2.5	4.7	P
		759.9	-61.11	-11.91	-49.2	-72.81	4.5	2.5	4.7	P
		11000	-62.63	-41.43	-21.2	-69.63	4.5	2.5	0	P
	16500	-54.22	-33.02	-21.2	-61.22	4.5	2.5	0	P	
802.11n HT20 CH 116 5580MHz		150.42	-60.39	-8.69	-51.7	-72.09	4.5	2.5	4.7	P
		171.21	-60.91	-9.21	-51.7	-72.61	4.5	2.5	4.7	P
		261.12	-59.91	-10.71	-49.2	-71.61	4.5	2.5	4.7	P
		559.7	-60.73	-11.53	-49.2	-72.43	4.5	2.5	4.7	P
		792.1	-60.82	-11.62	-49.2	-72.52	4.5	2.5	4.7	P
		888	-61.32	-12.12	-49.2	-73.02	4.5	2.5	4.7	P
		11160	-67.21	-46.01	-21.2	-74.21	4.5	2.5	0	P
	16740	-54.8	-33.6	-21.2	-61.8	4.5	2.5	0	P	
802.11n HT20 CH 140 5700MHz		40.8	-61.46	-6.26	-55.2	-73.16	4.5	2.5	4.7	P
		56.46	-61.54	-6.34	-55.2	-73.24	4.5	2.5	4.7	P
		97.77	-61.14	-9.44	-51.7	-72.84	4.5	2.5	4.7	P
		392.4	-60.51	-11.31	-49.2	-72.21	4.5	2.5	4.7	P
		617.1	-60.36	-11.16	-49.2	-72.06	4.5	2.5	4.7	P
		981.1	-61.18	-19.98	-41.2	-72.88	4.5	2.5	4.7	P
		11400	-62.43	-41.23	-21.2	-69.43	4.5	2.5	0	P
	17100	-53.64	-32.44	-21.2	-60.64	4.5	2.5	0	P	





**15E 5470~5725MHz**

**WIFI 802.11n HT40 (Harmonic @ 3m)**

WIFI	Note	Frequency	Level	Over	Limit	Read	Antenna	Cable	Grounding	Peak
Ant.				Limit	Line	Level	Gain	Loss	Factor	Avg
1		( MHz )	( dBμV/m )	( dB )	( dBμV/m )	( dBμV )	( dBi )	( dB )	( dB )	( P/A )
802.11n HT40 CH 102 5510MHz		60.24	-59.91	-4.71	-55.2	-71.61	4.5	2.5	4.7	P
		165.54	-59.97	-8.27	-51.7	-71.67	4.5	2.5	4.7	P
		237.09	-61.26	-12.06	-49.2	-72.96	4.5	2.5	4.7	P
		410.6	-60.13	-10.93	-49.2	-71.83	4.5	2.5	4.7	P
		551.3	-61.16	-11.96	-49.2	-72.86	4.5	2.5	4.7	P
		825.7	-60.88	-11.68	-49.2	-72.58	4.5	2.5	4.7	P
		11020	-63.95	-42.75	-21.2	-70.95	4.5	2.5	0	P
	16530	-54	-32.8	-21.2	-61	4.5	2.5	0	P	
802.11n HT40 CH 110 5550MHz		110.46	-59.87	-8.17	-51.7	-71.57	4.5	2.5	4.7	P
		217.38	-60.58	-11.38	-49.2	-72.28	4.5	2.5	4.7	P
		288.12	-60.46	-11.26	-49.2	-72.16	4.5	2.5	4.7	P
		384	-61.19	-11.99	-49.2	-72.89	4.5	2.5	4.7	P
		510	-60.61	-11.41	-49.2	-72.31	4.5	2.5	4.7	P
		731.9	-61.04	-11.84	-49.2	-72.74	4.5	2.5	4.7	P
		11100	-67.16	-45.96	-21.2	-74.16	4.5	2.5	0	P
	16650	-54.6	-33.4	-21.2	-61.6	4.5	2.5	0	P	
802.11n HT40 CH 134 5670MHz		66.99	-60.24	-5.04	-55.2	-71.94	4.5	2.5	4.7	P
		185.79	-60.31	-8.61	-51.7	-72.01	4.5	2.5	4.7	P
		256.26	-61.1	-11.9	-49.2	-72.8	4.5	2.5	4.7	P
		390.3	-60.68	-11.48	-49.2	-72.38	4.5	2.5	4.7	P
		744.5	-60.76	-11.56	-49.2	-72.46	4.5	2.5	4.7	P
		949.6	-59.96	-10.76	-49.2	-71.66	4.5	2.5	4.7	P
		11340	-66.15	-44.95	-21.2	-73.15	4.5	2.5	0	P
	17010	-53.74	-32.54	-21.2	-60.74	4.5	2.5	0	P	



15E 5470~5725MHz  
WIFI 802.11n HT40 (Harmonic @ 3m)

WIFI	Note	Frequency	Level	Over	Limit	Read	Antenna	Cable	Grounding	Peak
Ant.				Limit	Line	Level	Gain	Loss	Factor	Avg
2		( MHz )	( dBμV/m )	( dB )	( dBμV/m )	( dBμV )	( dBi )	( dB )	( dB )	( P/A )
802.11n HT40 CH 102 5510MHz		105.33	-60.89	-9.19	-51.7	-72.59	4.5	2.5	4.7	P
		145.83	-59.62	-7.92	-51.7	-71.32	4.5	2.5	4.7	P
		233.85	-62.57	-13.37	-49.2	-74.27	4.5	2.5	4.7	P
		464.5	-61.01	-11.81	-49.2	-72.71	4.5	2.5	4.7	P
		617.8	-60.76	-11.56	-49.2	-72.46	4.5	2.5	4.7	P
		701.1	-60.38	-11.18	-49.2	-72.08	4.5	2.5	4.7	P
		11020	-66.88	-45.68	-21.2	-73.88	4.5	2.5	0	P
	16530	-55.07	-33.87	-21.2	-62.07	4.5	2.5	0	P	
802.11n HT40 CH 110 5550MHz		69.96	-60.13	-4.93	-55.2	-71.83	4.5	2.5	4.7	P
		179.58	-59.95	-8.25	-51.7	-71.65	4.5	2.5	4.7	P
		253.56	-60.91	-11.71	-49.2	-72.61	4.5	2.5	4.7	P
		416.9	-60.61	-11.41	-49.2	-72.31	4.5	2.5	4.7	P
		573.7	-60.21	-11.01	-49.2	-71.91	4.5	2.5	4.7	P
		764.1	-61.21	-12.01	-49.2	-72.91	4.5	2.5	4.7	P
		11100	-65.52	-44.32	-21.2	-72.52	4.5	2.5	0	P
	16650	-56.22	-35.02	-21.2	-63.22	4.5	2.5	0	P	
802.11n HT40 CH 134 5670MHz		79.14	-60.23	-5.03	-55.2	-71.93	4.5	2.5	4.7	P
		149.61	-60.65	-8.95	-51.7	-72.35	4.5	2.5	4.7	P
		229.53	-60.44	-11.24	-49.2	-72.14	4.5	2.5	4.7	P
		411.3	-60.62	-11.42	-49.2	-72.32	4.5	2.5	4.7	P
		646.5	-61.09	-11.89	-49.2	-72.79	4.5	2.5	4.7	P
		883.1	-60.44	-11.24	-49.2	-72.14	4.5	2.5	4.7	P
		11340	-63.38	-42.18	-21.2	-70.38	4.5	2.5	0	P
	17010	-55.33	-34.13	-21.2	-62.33	4.5	2.5	0	P	



### 3.5 AC Conducted Emission Measurement

#### 3.5.1 Limit of AC Conducted Emission

For equipment that is designed to be connected to the public utility (AC) power line, the radio frequency voltage that is conducted back onto the AC power line on any frequency or frequencies within the band 150 kHz to 30 MHz shall not exceed the limits in the following table.

Frequency of emission (MHz)	Conducted limit (dBµV)	
	Quasi-peak	Average
0.15-0.5	66 to 56*	56 to 46*
0.5-5	56	46
5-30	60	50

\*Decreases with the logarithm of the frequency.

#### 3.5.2 Measuring Instruments

The measuring equipment is listed in the section 4 of this test report.

#### 3.5.3 Test Procedures

1. The EUT was placed 0.4 meter from the conducting wall of the shielding room was kept at least 80 centimeters from any other grounded conducting surface.
2. Connect EUT to the power mains through a line impedance stabilization network (LISN).
3. All the support units are connecting to the other LISN.
4. The LISN provides 50 ohm coupling impedance for the measuring instrument.
5. The FCC states that a 50 ohm, 50 microhenry LISN should be used.
6. Both sides of AC line were checked for maximum conducted interference.
7. The frequency range from 150 kHz to 30 MHz was searched.
8. Set the test-receiver system to Peak Detect Function and specified bandwidth with Maximum Hold Mode.

### 3.5.4 Test Setup

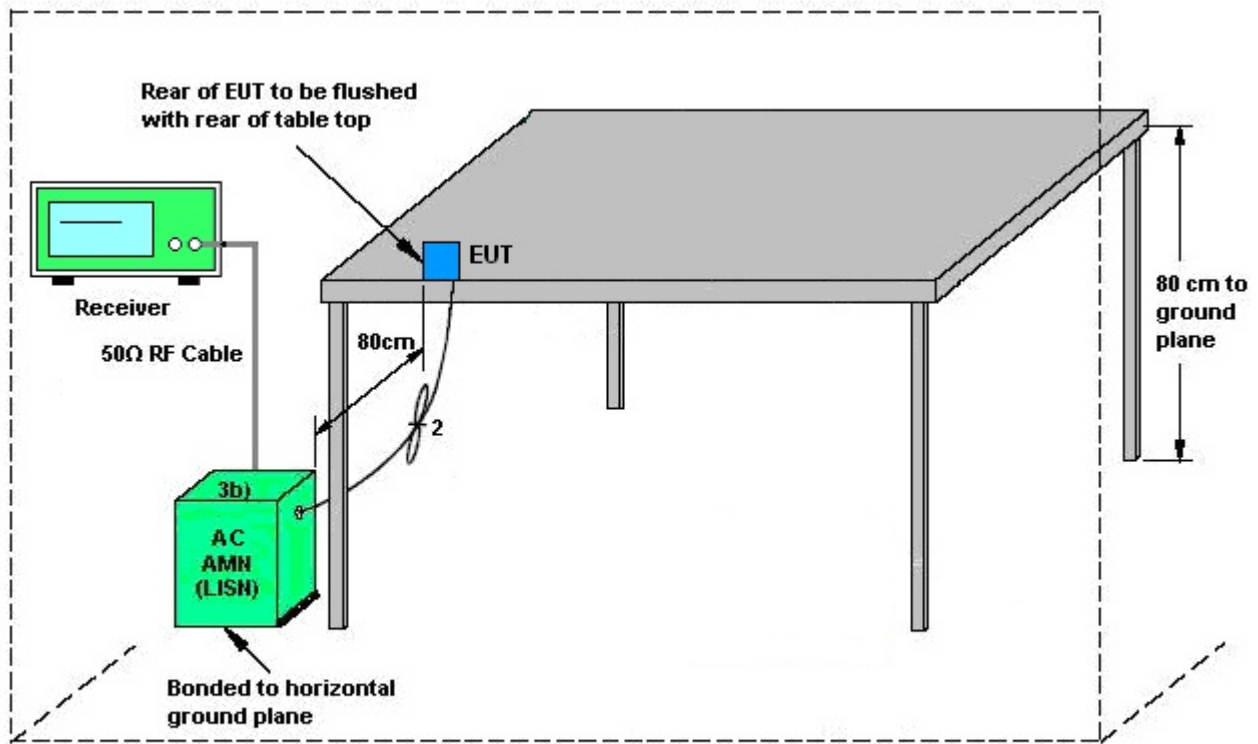

AMN = Artificial mains network (LISH)  
AE = Associated equipment  
EUT = Equipment under test  
ISN = Impedance stabilization network



### 3.5.5 Test Result of AC Conducted Emission

Test Mode :	Mode 1	Temperature :	25~26°C
Test Engineer :	Kai-Chun Chu	Relative Humidity :	47~48%
Test Voltage :	120Vac / 60Hz	Phase :	Line
Function Type :	WLAN (5GHz) Link + Bluetooth Link + Adapter		

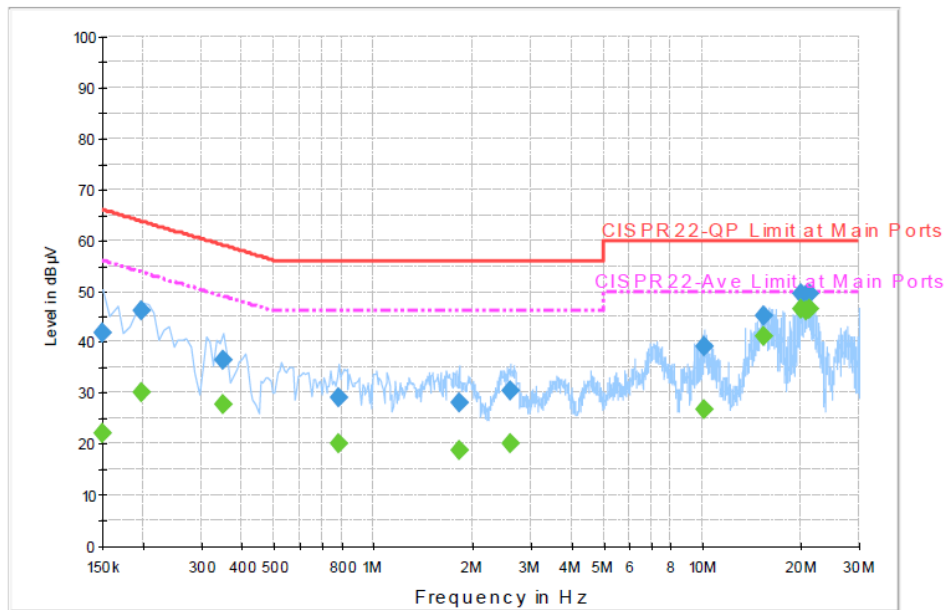

**Final Result : QuasiPeak**

Frequency (MHz)	QuasiPeak (dBµV)	Filter	Line	Corr. (dB)	Margin (dB)	Limit (dBµV)
0.150000	41.8	Off	L1	19.6	24.2	66.0
0.198000	46.3	Off	L1	19.6	17.4	63.7
0.350000	36.5	Off	L1	19.6	22.5	59.0
0.782000	29.1	Off	L1	19.6	26.9	56.0
1.822000	28.0	Off	L1	19.6	28.0	56.0
2.606000	30.4	Off	L1	19.6	25.6	56.0
10.198000	39.1	Off	L1	19.7	20.9	60.0
15.478000	45.2	Off	L1	19.8	14.8	60.0
19.918000	49.6	Off	L1	19.8	10.4	60.0

**Final Result : Average**

Frequency (MHz)	Average (dBµV)	Filter	Line	Corr. (dB)	Margin (dB)	Limit (dBµV)
0.150000	22.0	Off	L1	19.6	34.0	56.0
0.198000	30.0	Off	L1	19.6	23.7	53.7
0.350000	27.8	Off	L1	19.6	21.2	49.0
0.782000	20.2	Off	L1	19.6	25.8	46.0
1.822000	18.7	Off	L1	19.6	27.3	46.0
2.606000	20.0	Off	L1	19.6	26.0	46.0
10.198000	26.7	Off	L1	19.7	23.3	50.0
15.478000	41.2	Off	L1	19.8	8.8	50.0
19.918000	46.5	Off	L1	19.8	3.5	50.0



Test Mode :	Mode 1	Temperature :	25~26°C
Test Engineer :	Kai-Chun Chu	Relative Humidity :	47~48%
Test Voltage :	120Vac / 60Hz	Phase :	Neutral
Function Type :	WLAN (5GHz) Link + Bluetooth Link + Adapter		

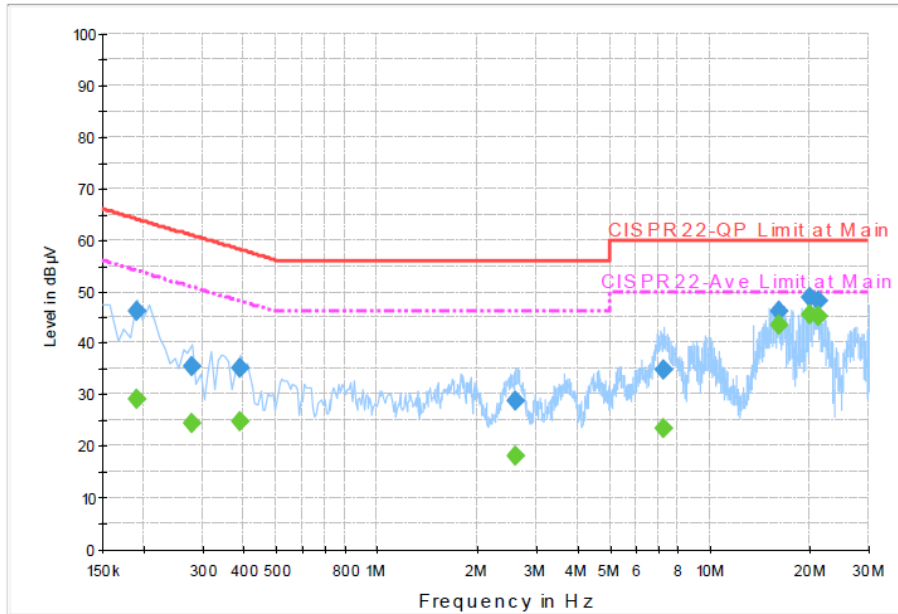

**Final Result : QuasiPeak**

Frequency (MHz)	QuasiPeak (dBµV)	Filter	Line	Corr. (dB)	Margin (dB)	Limit (dBµV)
0.190000	46.0	Off	N	19.6	18.0	64.0
0.278000	35.3	Off	N	19.6	25.6	60.9
0.390000	35.1	Off	N	19.6	23.0	58.1
2.598000	28.6	Off	N	19.6	27.4	56.0
7.270000	34.7	Off	N	19.7	25.3	60.0
16.078000	46.3	Off	N	19.9	13.7	60.0
19.918000	48.7	Off	N	19.9	11.3	60.0
21.158000	48.2	Off	N	20.0	11.8	60.0
0.190000	46.0	Off	N	19.6	18.0	64.0
0.278000	35.3	Off	N	19.6	25.6	60.9

**Final Result : Average**

Frequency (MHz)	Average (dBµV)	Filter	Line	Corr. (dB)	Margin (dB)	Limit (dBµV)
0.190000	29.2	Off	N	19.6	24.8	54.0
0.278000	24.3	Off	N	19.6	26.6	50.9
0.390000	24.8	Off	N	19.6	23.3	48.1
2.598000	18.2	Off	N	19.6	27.8	46.0
7.270000	23.5	Off	N	19.7	26.5	50.0
16.078000	43.6	Off	N	19.9	6.4	50.0
19.918000	45.4	Off	N	19.9	4.6	50.0
21.158000	45.3	Off	N	20.0	4.7	50.0
0.190000	29.2	Off	N	19.6	24.8	54.0
0.278000	24.3	Off	N	19.6	26.6	50.9

## 3.6 Frequency Stability Measurement

### 3.6.1 Limit of Frequency Stability

Manufacturers of U-NII devices are responsible for ensuring frequency stability such that an emission is maintained within the band of operation under all conditions of normal operation as specified in the user's manual.

### 3.6.2 Measuring Instruments

The measuring equipment is listed in the section 4 of this test report.

### 3.6.3 Test Procedures

1. To ensure emission at the band edge is maintained within the authorized band, those values shall be measured by radiation emissions at upper and lower frequency points, and finally compensated by frequency deviation as procedures below.
2. The EUT was operated at the maximum output power, and connected to the spectrum analyzer, which is set to maximum hold function and peak detector. The peak value of the power envelope was measured and noted. The upper and lower frequency points were respectively measured relatively 10dB lower than the measured peak value.
3. The frequency deviation was calculated by adding the upper frequency point and the lower frequency point divided by two. Those detailed values of frequency deviation are provided in table below.

### 3.6.4 Test Setup



### 3.6.5 Test Result of Frequency Stability

Please refer to Appendix A.



## **3.7 Automatically Discontinue Transmission**

### **3.7.1 Limit of Automatically Discontinue Transmission**

The device shall automatically discontinue transmission in case of either absence of information to transmit or operational failure. These provisions are not intended to preclude the transmission of control or signaling information or the use of repetitive codes used by certain digital technologies to complete frame or burst intervals. Applicants shall include in their application for equipment authorization to describe how this requirement is met.

### **3.7.2 Measuring Instruments**

The measuring equipment is listed in the section 4 of this test report.

### **3.7.3 Test Result of Automatically Discontinue Transmission**

While the EUT is not transmitting any information, the EUT can automatically discontinue transmission and become standby mode for power saving. The EUT can detect the controlling signal of ACK message transmitting from remote device and verify whether it shall resend or discontinue transmission.





### 3.8 Antenna Requirements

#### 3.8.1 Standard Applicable

According to FCC 47 CFR Section 15.407(a)(1)(2) ,if transmitting antenna directional gain is greater than 6 dBi, both the peak transmit power and the peak power spectral density shall be reduced by the amount in dB that the directional gain of the antenna exceeds 6 dBi.

#### 3.8.2 Antenna Anti-Replacement Construction

Non-standard antenna connector is used.

#### 3.8.3 Antenna Gain

FCC KDB 662911 D01 Multiple Transmitter Output v02r01

For CDD transmissions, directional gain is calculated as

Directional gain =  $G_{ANT} + \text{Array Gain}$ , where Array Gain is as follows.

For power spectral density (PSD) measurements on all devices,

Array Gain =  $10 \log(N_{ANT}/N_{SS}=1)$  dB.

For power measurements on IEEE 802.11 devices,

Array Gain = 0 dB (i.e., no array gain) for  $N_{ANT} \leq 4$ .

The EUT supports CDD mode.

The power and PSD limit should be modified if the directional gain of EUT is over 6 dBi,

The directional gain “DG” is calculated as following table.

			DG	DG	Power	PSD
			for	for	Limit	Limit
	Ant 1	Ant 2	Power	PSD	Reduction	Reduction
	(dBi)	(dBi)	(dBi)	(dBi)	(dB)	(dB)
Band I	4.50	4.50	4.50	7.51	0.00	1.51
Band II	4.50	4.50	4.50	7.51	0.00	1.51
Band III	4.50	4.50	4.50	7.51	0.00	1.51

Power limit reduction = Composite gain – 6dBi, ( min = 0 )

PSD limit reduction = Composite gain + PSD Array gain – 6dBi, ( min = 0 )



## 4 List of Measuring Equipment

Instrument	Manufacturer	Model No.	Serial No.	Characteristics	Calibration Date	Test Date	Due Date	Remark
Spectrum Analyzer	Rohde & Schwarz	FSP40	100055	9kHz~40GHz	Jun. 09, 2014	Dec. 12, 2014	Jun. 08, 2015	Conducted (TH02-HY)
Power Meter	Anritsu	ML2495A	1036004	300MHz~40GHz	Aug. 09, 2014	Dec. 12, 2014	Aug. 08, 2015	Conducted (TH02-HY)
Power Sensor	Anritsu	MA2411B	1027253	300MHz~40GHz	Aug. 09, 2014	Dec. 12, 2014	Aug. 08, 2015	Conducted (TH02-HY)
Loop Antenna	Rohde & Schwarz	HFH2-Z2	100315	9 kHz~30 MHz	Sep. 02, 2015	May 27, 2016 ~ May 31, 2016	Sep. 01, 2016	Radiation (03CH12-HY)
Amplifier	SONOMA	310N	187312	9kHz~1GHz	Nov. 20, 2015	May 27, 2016 ~ May 31, 2016	Nov. 19, 2016	Radiation (03CH12-HY)
Spectrum Analyzer	Keysight	N9010A	MY54200486	10Hz ~ 44GHZ	Sep. 24, 2015	May 27, 2016 ~ May 31, 2016	Sep. 23, 2016	Radiation (03CH12-HY)
Bilog Antenna	TESEQ	CBL 6111D	37059	30MHz~1GHz	Dec. 29, 2015	May 27, 2016 ~ May 31, 2016	Dec. 28, 2016	Radiation (03CH12-HY)
EMI Test Receiver	Rohde & Schwarz	ESU26	100390	20Hz~26.5GHz	Dec. 21, 2015	May 27, 2016 ~ May 31, 2016	Dec. 20, 2016	Radiation (03CH12-HY)
Preamplifier	MITEQ	JS44-1800400 0-33-8P	1840917	18GHz ~ 40GHz	Jun. 02, 2015	May 27, 2016 ~ May 31, 2016	Jun. 01, 2016	Radiation (03CH12-HY)
Horn Antenna	SCHWARZBECK	BBHA 9120D	9120D-1328	1GHz ~ 18GHz	Nov. 02, 2015	May 27, 2016 ~ May 31, 2016	Nov. 01, 2016	Radiation (03CH12-HY)
Preamplifier	MITEQ	AMF-7D-0010 1800-30-10P	1815698	1GHz~18GHz	Dec. 14, 2015	May 27, 2016 ~ May 31, 2016	Dec. 13, 2016	Radiation (03CH12-HY)
Antenna Mast	EMEC	AM-BS-4500-B	N/A	1m~4m	N/A	May 27, 2016 ~ May 31, 2016	N/A	Radiation (03CH12-HY)
Turn Table	EMEC	TT2000	N/A	0~360 Degree	N/A	May 27, 2016 ~ May 31, 2016	N/A	Radiation (03CH12-HY)
SHF-EHF Horn Antenna	SCHWARZBECK	BBHA 9170	BBHA9170584	18GHz- 40GHz	Nov. 02, 2015	May 27, 2016 ~ May 31, 2016	Nov. 01, 2016	Radiation (03CH12-HY)
AC Power Source	ChainTek	APC-1000W	N/A	N/A	N/A	Jun. 15, 2016	N/A	Conduction (CO05-HY)
EMI Test Receiver	Rohde & Schwarz	ESCI 7	100724	9kHz~7GHz	Aug. 26, 2015	Jun. 15, 2016	Aug. 25, 2016	Conduction (CO05-HY)
LISN	Rohde & Schwarz	ENV216	100080	9kHz~30MHz	Dec. 02, 2015	Jun. 15, 2016	Dec. 01, 2016	Conduction (CO05-HY)

5/28~6/1



## 5 Uncertainty of Evaluation

### Uncertainty of Conducted Emission Measurement (150kHz ~ 30MHz)

Measuring Uncertainty for a Level of Confidence of 95% ( $U = 2Uc(y)$ )	2.26
---	------

### Uncertainty of Radiated Emission Measurement (30 MHz ~ 1000 MHz)

Measuring Uncertainty for a Level of Confidence of 95% ( $U = 2Uc(y)$ )	4.90
---	------



## Appendix A. Test Result of conducted Test Results

Report Number : CR651030D

Test Engineer:	Alex Lee	Temperature:	21~25	°C
Test Date:	2014/12/12	Relative Humidity:	51~54	%

**TEST RESULTS DATA**  
**26dB and 99% OBW**

Band I													
Mod.	Data Rate	NTX	Channe	Freq. (MHz)	99% Bandwidth (MHz)		26 dB Bandwidth (MHz)		IC 99% Bandwidth Power Limit (dBm)		IC 99% Bandwidth EIRP Limit (dBm)		Note
					Ant 1	Ant 2	Ant 1	Ant 2	Ant 1	Ant 2	Ant 1	Ant 2	
11a	6Mbps	1	36	5180		17.80		27.65		-		22.50	
11a	6Mbps	1	44	5220		17.65		25.50		-		22.47	
11a	6Mbps	1	48	5240		18.35		28.15		-		22.64	
HT20	MCS0	1	36	5180		18.50		27.80		-		22.67	
HT20	MCS0	1	44	5220		18.45		27.90		-		22.66	
HT20	MCS0	1	48	5240		18.60		28.60		-		22.70	
HT40	MCS0	1	38	5190		36.10		45.09		-		23.01	
HT40	MCS0	1	46	5230		36.20		52.65		-		23.01	

**TEST RESULTS DATA**  
**Average Power Table**

IC Band I																
Mod.	Data Rate	N <sub>TX</sub>	Channel	Freq. (MHz)	Duty Factor (dB)		Average Conducted Power (dBm)			IC Conducted Power Limit (dBm)		DG (dBi)		IC EIRP Power Limit (dBm)		Pass /Fail
					Ant 1	Ant 2	Ant 1	Ant 2	SUM	Ant 1	Ant 2	Ant 1	Ant 2	Ant 1	Ant 2	
11a	6Mbps	1	36	5180	4.90	4.90	15.54	15.71	-		22.50	0.00	0.00		22.50	Pass
11a	6Mbps	1	44	5220	4.90	4.90	15.58	15.82	-		22.47	0.00	0.00		22.47	Pass
11a	6Mbps	1	48	5240	4.90	4.90	15.40	15.56	-		22.64	0.00	0.00		22.64	Pass
HT20	MCS0	1	36	5180	4.77	4.77	15.71	15.54	-		22.67	0.00	0.00		22.67	Pass
HT20	MCS0	1	44	5220	4.77	4.77	15.35	15.53	-		22.66	0.00	0.00		22.66	Pass
HT20	MCS0	1	48	5240	4.77	4.77	15.28	15.48	-		22.70	0.00	0.00		22.70	Pass
HT40	MCS0	1	38	5190	5.17	5.17	11.48	11.76	-		23.01	0.00	0.00		23.01	Pass
HT40	MCS0	1	46	5230	5.17	5.17	16.60	16.98	-		23.01	0.00	0.00		23.01	Pass

**TEST RESULTS DATA**  
**Power Spectral Density**

IC Band I																
Mod.	Data Rate	NTX	Channel	Freq. (MHz)	Duty Factor (dB)		Average Power Density (dBm/MHz)			Average PSD Limit (dBm/MHz)		DG (dBi)		IC EIRP PSD Limit (dBm/MHz)		Pass /Fail
					Ant 1	Ant 2	Ant 1	Ant 2	SUM	Ant 1	Ant 2	Ant 1	Ant 2	Ant 1	Ant 2	
11a	6Mbps	1	36	5180	4.90	4.90		5.17		5.50	5.50	4.50	4.50	10	10	Pass
11a	6Mbps	1	44	5220	4.90	4.90		5.35		5.50	5.50	4.50	4.50	10	10	Pass
11a	6Mbps	1	48	5240	4.90	4.90		5.18		5.50	5.50	4.50	4.50	10	10	Pass
HT20	MCS0	1	36	5180	4.77	4.77		4.81		5.50	5.50	4.50	4.50	10	10	Pass
HT20	MCS0	1	44	5220	4.77	4.77		5.36		5.50	5.50	4.50	4.50	10	10	Pass
HT20	MCS0	1	48	5240	4.77	4.77		4.93		5.50	5.50	4.50	4.50	10	10	Pass
HT40	MCS0	1	38	5190	5.17	5.17		-3.04		5.50	5.50	4.50	4.50	10	10	Pass
HT40	MCS0	1	46	5230	5.17	5.17		3.51		5.50	5.50	4.50	4.50	10	10	Pass



**TEST RESULTS DATA**  
**26dB and 99% OBW**

Band II															
Mod.	Data Rate	NTX	Channe	Freq. (MHz)	99% Bandwidth (MHz)		26 dB Bandwidth (MHz)		IC 99% Bandwidth Power Limit (dBm)		IC 99% Bandwidth EIRP Limit (dBm)		FCC 26dB Bandwidth Power Limit (dBm)		Note
					Ant 1	Ant 2	Ant 1	Ant 2	Ant 1	Ant 2	Ant 1	Ant 2	Ant 1	Ant 2	
11a	6Mbps	1	52	5260		17.50		25.50		23.43		29.43		23.98	
11a	6Mbps	1	60	5300		17.35		26.35		23.39		29.39		23.98	
11a	6Mbps	1	64	5320		17.40		25.50		23.41		29.41		23.98	
HT20	MCS0	1	52	5260		18.75		28.10		23.73		29.73		23.98	
HT20	MCS0	1	60	5300		18.60		27.95		23.70		29.70		23.98	
HT20	MCS0	1	64	5320		18.55		28.30		23.68		29.68		23.98	
HT40	MCS0	1	54	5270		36.50		54.81		23.98		30.00		23.98	
HT40	MCS0	1	62	5310		35.90		45.36		23.98		30.00		23.98	

**TEST RESULTS DATA**  
**Average Power Table**

IC Band II																
Mod.	Data Rate	N <sub>TX</sub>	Channel	Freq. (MHz)	Duty Factor (dB)		Average Conducted Power (dBm)			IC Conducted Power Limit (dBm)		DG (dBi)		IC EIRP Power Limit (dBm)		Pass /Fail
					Ant 1	Ant 2	Ant 1	Ant 2	SUM	Ant 1	Ant 2	Ant 1	Ant 2	Ant 1	Ant 2	
11a	6Mbps	1	52	5260	4.90	4.90	13.20	13.30	-		24.93	4.50	4.50		29.43	Pass
11a	6Mbps	1	60	5300	4.90	4.90	12.94	13.48	-		24.89	4.50	4.50		29.39	Pass
11a	6Mbps	1	64	5320	4.90	4.90	12.98	13.28	-		24.91	4.50	4.50		29.41	Pass
HT20	MCS0	1	52	5260	4.77	4.77	13.12	13.44	-		25.23	4.50	4.50		29.73	Pass
HT20	MCS0	1	60	5300	4.77	4.77	13.27	13.87	-		25.20	4.50	4.50		29.70	Pass
HT20	MCS0	1	64	5320	4.77	4.77	12.79	13.37	-		25.18	4.50	4.50		29.68	Pass
HT40	MCS0	1	54	5270	5.17	5.17	16.86	17.20	-		25.50	4.50	4.50		30.00	Pass
HT40	MCS0	1	62	5310	5.17	5.17	11.80	12.22	-		25.50	4.50	4.50		30.00	Pass

**TEST RESULTS DATA**  
**Power Spectral Density**

Band II														
Mod.	Data Rate	NTX	Channel	Freq. (MHz)	Duty Factor (dB)		Average Power Density (dBm/MHz)			Average PSD Limit (dBm/MHz)		DG (dBi)		Pass /Fail
					Ant 1	Ant 2	Ant 1	Ant 2	SUM	Ant 1	Ant 2	Ant 1	Ant 2	
11a	6Mbps	1	52	5260	4.90	4.90		1.84		11.00	11.00	4.50	4.50	Pass
11a	6Mbps	1	60	5300	4.90	4.90		2.31		11.00	11.00	4.50	4.50	Pass
11a	6Mbps	1	64	5320	4.90	4.90		1.67		11.00	11.00	4.50	4.50	Pass
HT20	MCS0	1	52	5260	4.77	4.77		1.70		11.00	11.00	4.50	4.50	Pass
HT20	MCS0	1	60	5300	4.77	4.77		2.09		11.00	11.00	4.50	4.50	Pass
HT20	MCS0	1	64	5320	4.77	4.77		1.64		11.00	11.00	4.50	4.50	Pass
HT40	MCS0	1	54	5270	5.17	5.17		2.94		11.00	11.00	4.50	4.50	Pass
HT40	MCS0	1	62	5310	5.17	5.17		-2.54		11.00	11.00	4.50	4.50	Pass

**TEST RESULTS DATA**  
**26dB and 99% OBW**

Band III															
Mod.	Data Rate	NTX	Channel	Freq. (MHz)	99% Bandwidth (MHz)		26 dB Bandwidth (MHz)		IC 99% Bandwidth Power Limit (dBm)		IC 99% Bandwidth EIRP Limit (dBm)		FCC 26dB Bandwidth Power Limit (dBm)		Note
					Ant 1	Ant 2	Ant 1	Ant 2	Ant 1	Ant 2	Ant 1	Ant 2	Ant 1	Ant 2	
11a	6Mbps	1	100	5500		17.50		27.05		23.43		29.43		23.98	
11a	6Mbps	1	116	5580		19.05		33.35		23.80		29.80		23.98	
11a	6Mbps	1	140	5700		17.25		25.30		23.37		29.37		23.98	
HT20	MCS0	1	100	5500		18.85		29.20		23.75		29.75		23.98	
HT20	MCS0	1	116	5580		18.75		28.60		23.73		29.73		23.98	
HT20	MCS0	1	140	5700		18.50		27.80		23.67		29.67		23.98	
HT40	MCS0	1	102	5510		36.00		44.64		23.98		30.00		23.98	
HT40	MCS0	1	110	5550		36.50		57.69		23.98		30.00		23.98	
HT40	MCS0	1	134	5670		36.10		48.15		23.98		30.00		23.98	

**TEST RESULTS DATA**  
**Average Power Table**

IC Band III																
Mod.	Data Rate	N <sub>TX</sub>	Channe	Freq. (MHz)	Duty Factor (dB)		Average Conducted Power (dBm)			IC Conducted Power Limit (dBm)		DG (dBi)		IC EIRP Power Limit (dBm)		Pass /Fail
					Ant 1	Ant 2	Ant 1	Ant 2	SUM	Ant 1	Ant 2	Ant 1	Ant 2	Ant 1	Ant 2	
11a	6Mbps	1	100	5500	4.90	4.90	14.30	14.52			24.93	4.50	4.50		29.43	Pass
11a	6Mbps	1	116	5580	4.90	4.90	17.50	18.44			25.30	4.50	4.50		29.80	Pass
11a	6Mbps	1	140	5700	4.90	4.90	11.82	11.94			24.87	4.50	4.50		29.37	Pass
HT20	MCS0	1	100	5500	4.77	4.77	14.06	14.93			25.25	4.50	4.50		29.75	Pass
HT20	MCS0	1	116	5580	4.77	4.77	17.24	17.52	-		25.23	4.50	4.50		29.73	Pass
HT20	MCS0	1	140	5700	4.77	4.77	11.76	12.19			25.17	4.50	4.50		29.67	Pass
HT40	MCS0	1	102	5510	5.17	5.17	11.52	11.28			25.50	4.50	4.50		30.00	Pass
HT40	MCS0	1	110	5550	5.17	5.17	15.78	16.74			25.50	4.50	4.50		30.00	Pass
HT40	MCS0	1	134	5670	5.17	5.17	12.56	12.83			25.50	4.50	4.50		30.00	Pass

**TEST RESULTS DATA**  
**Power Spectral Density**

Band III														
Mod.	Data Rate	NTX	Channel	Freq. (MHz)	Duty Factor (dB)		Average Power Density (dBm/MHz)			Average PSD Limit (dBm/MHz)		DG (dBi)		Pass /Fail
					Ant 1	Ant 2	Ant 1	Ant 2	SUM	Ant 1	Ant 2	Ant 1	Ant 2	
11a	6Mbps	1	100	5500	4.90	4.90		3.18		11.00	11.00	4.50	4.50	Pass
11a	6Mbps	1	116	5580	4.90	4.90		6.91		11.00	11.00	4.50	4.50	Pass
11a	6Mbps	1	140	5700	4.90	4.90		0.06		11.00	11.00	4.50	4.50	Pass
HT20	MCS0	1	100	5500	4.77	4.77		2.86		11.00	11.00	4.50	4.50	Pass
HT20	MCS0	1	116	5580	4.77	4.77		5.95	-	11.00	11.00	4.50	4.50	Pass
HT20	MCS0	1	140	5700	4.77	4.77		-0.43		11.00	11.00	4.50	4.50	Pass
HT40	MCS0	1	102	5510	5.17	5.17		-0.42		11.00	11.00	4.50	4.50	Pass
HT40	MCS0	1	110	5550	5.17	5.17		2.90		11.00	11.00	4.50	4.50	Pass
HT40	MCS0	1	134	5670	5.17	5.17		-1.98		11.00	11.00	4.50	4.50	Pass

**TEST RESULTS DATA**  
**Frequency Stability**

Band I										
Mod.	Data Rate	NTX	Channe	Freq. (MHz)	Center Frequency (MHz)	Frequency Deviation (MHz)	Frequency Stability (ppm)	Temperature (°C)	Voltage (V)	Note
11a	6Mbps	1	36	5180	5180.000	0.000	0.00	20	108	
11a	6Mbps	1	36	5180	5180.000	0.000	0.00	20	132	
11a	6Mbps	1	36	5180	5180.000	0.000	0.00	20	120	
11a	6Mbps	1	36	5180	5180.000	0.000	0.00	-30	120	
11a	6Mbps	1	36	5180	5180.000	0.000	0.00	50	120	

Band II										
Mod.	Data Rate	NTX	Channe	Freq. (MHz)	Center Frequency (MHz)	Frequency Deviation (MHz)	Frequency Stability (ppm)	Temperature (°C)	Voltage (V)	Note
11a	6Mbps	1	64	5320	5320.000	0.000	0.00	20	108	
11a	6Mbps	1	64	5320	5320.000	0.000	0.00	20	132	
11a	6Mbps	1	64	5320	5320.000	0.000	0.00	20	120	
11a	6Mbps	1	64	5320	5320.000	0.000	0.00	-30	120	
11a	6Mbps	1	64	5320	5320.000	0.000	0.00	50	120	

Band III										
Mod.	Data Rate	NTX	Channe	Freq. (MHz)	Center Frequency (MHz)	Frequency Deviation (MHz)	Frequency Stability (ppm)	Temperature (°C)	Voltage (V)	Note
11a	6Mbps	1	100	5500	5500.000	0.000	0.00	20	108	
11a	6Mbps	1	100	5500	5500.000	0.000	0.00	20	132	
11a	6Mbps	1	100	5500	5500.000	0.000	0.00	20	120	
11a	6Mbps	1	100	5500	5500.000	0.000	0.00	-30	120	
11a	6Mbps	1	100	5500	5500.000	0.000	0.00	50	120	



## Appendix B. Radiated Spurious Emission

Test Engineer :	Citta Ke, Nick Yu, and Ricky Su	Temperature :	22~23°C
		Relative Humidity :	56~58%

Band 1 - 5150~5250MHz

WIFI 802.11a (Band Edge @ 3m)

WIFI	Note	Frequency	Level	Over	Limit	Read	Antenna	Cable	Preamp	Ant	Table	Peak	Pol.	
Ant.				Limit	Line	Level	Factor	Loss	Factor	Pos	Pos	Avg.		
1		( MHz )	( dBμV/m )	( dB )	( dBμV/m )	( dBμV )	( dB/m )	( dB )	( dB )	( cm )	( deg )	( P/A )	( H/V )	
802.11a CH 36 5180MHz		5094.35	58.92	-15.08	74	47	31.6	11.27	30.95	100	118	P	H	
		5076.35	46.96	-7.04	54	35.06	31.58	11.27	30.95	100	118	A	H	
	*	5179	94.55	-	-	82.61	31.68	11.21	30.95	100	118	P	H	
	*	5179	83.83	-	-	71.89	31.68	11.21	30.95	100	118	A	H	
													H	
													H	
			5081.3	59.49	-14.51	74	47.59	31.58	11.27	30.95	284	103	P	V
			5119.25	47.04	-6.96	54	35.13	31.62	11.24	30.95	284	103	A	V
	*		5181	89.32	-	-	77.41	31.68	11.18	30.95	284	103	P	V
	*		5181	79.13	-	-	67.22	31.68	11.18	30.95	284	103	A	V
													V	
													V	
802.11a CH 44 5220MHz		5053.85	58.71	-15.29	74	46.8	31.55	11.31	30.95	100	118	P	H	
		5133.8	46.94	-7.06	54	35.02	31.63	11.24	30.95	100	118	A	H	
	*	5219	94.45	-	-	82.5	31.72	11.18	30.95	100	118	P	H	
	*	5219	84.42	-	-	72.47	31.72	11.18	30.95	100	118	A	H	
			5409.07	59.5	-14.5	74	46.95	31.9	11.6	30.95	100	118	P	H
			5437.01	47.64	-6.36	54	35.02	31.93	11.64	30.95	100	118	A	H
			5079.35	61.08	-12.92	74	49.18	31.58	11.27	30.95	311	99	P	V
			5003.15	46.98	-7.02	54	35.09	31.5	11.34	30.95	311	99	A	V
	*		5222	89.24	-	-	77.21	31.72	11.26	30.95	311	99	P	V
	*		5222	78.97	-	-	66.94	31.72	11.26	30.95	311	99	A	V
			5402.14	61.28	-12.72	74	48.73	31.9	11.6	30.95	311	99	P	V
			5385.2	47.65	-6.35	54	35.12	31.88	11.6	30.95	311	99	A	V





<b>802.11a CH 48 5240MHz</b>		5019.5	59.06	-14.94	74	47.15	31.52	11.34	30.95	100	118	P	H
		5136.35	46.94	-7.06	54	35.02	31.63	11.24	30.95	100	118	A	H
	*	5242	94.18	-	-	82.12	31.75	11.26	30.95	100	118	P	H
	*	5242	83.35	-	-	71.29	31.75	11.26	30.95	100	118	A	H
		5441.63	59.97	-14.03	74	47.35	31.93	11.64	30.95	100	118	P	H
		5413.14	47.66	-6.34	54	35.09	31.92	11.6	30.95	100	118	A	H
		5071.4	59.56	-14.44	74	47.67	31.57	11.27	30.95	277	98	P	V
		5085.05	47.05	-6.95	54	35.15	31.58	11.27	30.95	277	98	A	V
	*	5242	88.15	-	-	76.09	31.75	11.26	30.95	277	98	P	V
	*	5242	78.17	-	-	66.11	31.75	11.26	30.95	277	98	A	V
		5361.33	59.85	-14.15	74	47.41	31.87	11.52	30.95	277	98	P	V
		5418.75	47.69	-6.31	54	35.12	31.92	11.6	30.95	277	98	A	V
Remark	<p>1. No other spurious found.</p> <p>2. All results are PASS against Peak and Average limit line.</p>												



Band 1 5150~5250MHz

WIFI 802.11a (Harmonic @ 3m)

WIFI Ant. 1	Note	Frequency ( MHz )	Level ( dBμV/m )	Over Limit ( dB )	Limit Line ( dBμV/m )	Read Level ( dBμV )	Antenna Factor ( dB/m )	Cable Loss ( dB )	Preamp Factor ( dB )	Ant Pos ( cm )	Table Pos ( deg )	Peak Avg. ( P/A )	Pol. ( H/V )
802.11a CH 36 5180MHz		10360	47.31	-26.69	74	48.06	39.59	17.13	57.47	100	0	P	H
		15540	45.67	-28.33	74	44.33	38.26	21.61	58.53	100	0	P	H
													H
													H
		10360	48.54	-25.46	74	49.29	39.59	17.13	57.47	100	0	P	V
		15540	44.43	-29.57	74	43.09	38.26	21.61	58.53	100	0	P	V
													V
													V
802.11a CH 44 5220MHz		10440	47.62	-26.38	74	48.04	39.69	17.22	57.33	100	0	P	H
		15660	45.49	-28.51	74	43.97	38.11	21.7	58.29	100	0	P	H
													H
													H
		10440	49.04	-24.96	74	49.46	39.69	17.22	57.33	100	0	P	V
		15660	44.98	-29.02	74	43.46	38.11	21.7	58.29	100	0	P	V
													V
													V
802.11a CH 48 5240MHz		10480	47.75	-26.25	74	47.94	39.77	17.27	57.23	100	0	P	H
		15720	44.29	-29.71	74	42.65	38.03	21.76	58.15	100	0	P	H
													H
													H
		10480	47.56	-26.44	74	47.75	39.77	17.27	57.23	100	0	P	V
		15720	44.17	-29.83	74	42.53	38.03	21.76	58.15	100	0	P	V
													V
													V
Remark	1. No other spurious found. 2. All results are PASS against Peak and Average limit line.												



Band 1 5150~5250MHz

WIFI 802.11n HT40 (Band Edge @ 3m)

WIFI Ant. 1	Note	Frequency ( MHz )	Level ( dBμV/m )	Over Limit ( dB )	Limit Line ( dBμV/m )	Read Level ( dBμV )	Antenna Factor ( dB/m )	Cable Loss ( dB )	Preamp Factor ( dB )	Ant Pos ( cm )	Table Pos ( deg )	Peak Avg. ( P/A )	Pol. ( H/V )	
802.11n HT40 CH 38 5190MHz		5127.05	58.68	-15.32	74	46.76	31.63	11.24	30.95	100	150	P	H	
		5130.8	47.49	-6.51	54	35.57	31.63	11.24	30.95	100	150	A	H	
	*	5190	86.42	-	-	74.51	31.68	11.18	30.95	100	150	P	H	
	*	5190	76.27	-	-	64.36	31.68	11.18	30.95	100	150	A	H	
		5396.2	59.74	-14.26	74	47.19	31.9	11.6	30.95	100	150	P	H	
		5430.85	48.34	-5.66	54	35.72	31.93	11.64	30.95	100	150	A	H	
		5124.5	59.24	-14.76	74	47.32	31.63	11.24	30.95	313	98	P	V	
		5099.6	47.51	-6.49	54	35.59	31.6	11.27	30.95	313	98	A	V	
	*	5190	84.52	-	-	72.61	31.68	11.18	30.95	313	98	P	V	
	*	5190	73.63	-	-	61.72	31.68	11.18	30.95	313	98	A	V	
		5449.22	60.11	-13.89	74	47.47	31.95	11.64	30.95	313	98	P	V	
		5389.93	48.12	-5.88	54	35.59	31.88	11.6	30.95	313	98	A	V	
	802.11n HT40 CH 46 5230MHz		5026.55	58.91	-15.09	74	47.02	31.53	11.31	30.95	100	148	P	H
			5143.55	47.54	-6.46	54	35.63	31.65	11.21	30.95	100	148	A	H
*		5230	90.88	-	-	78.84	31.73	11.26	30.95	100	148	P	H	
*		5230	80.97	-	-	68.93	31.73	11.26	30.95	100	148	A	H	
		5403.35	60.94	-13.06	74	48.39	31.9	11.6	30.95	100	148	P	H	
		5416.44	48.08	-5.92	54	35.51	31.92	11.6	30.95	100	148	A	H	
		5013.5	59.64	-14.36	74	47.73	31.52	11.34	30.95	311	99	P	V	
		5091.65	47.42	-6.58	54	35.5	31.6	11.27	30.95	311	99	A	V	
*		5230	88.57	-	-	76.53	31.73	11.26	30.95	311	99	P	V	
*		5230	78.4	-	-	66.36	31.73	11.26	30.95	311	99	A	V	
	5447.68	59.78	-14.22	74	47.14	31.95	11.64	30.95	311	99	P	V		
	5416.99	48.12	-5.88	54	35.55	31.92	11.6	30.95	311	99	A	V		
Remark	1. No other spurious found. 2. All results are PASS against Peak and Average limit line.													



**Band 1 5150~5250MHz**

**WIFI 802.11n HT40 (Harmonic @ 3m)**

WIFI Ant. 1	Note	Frequency ( MHz )	Level ( dBμV/m )	Over Limit ( dB )	Limit Line ( dBμV/m )	Read Level (dBμV)	Antenna Factor ( dB/m )	Cable Loss ( dB )	Preamp Factor ( dB )	Ant Pos ( cm )	Table Pos ( deg )	Peak Avg. (P/A)	Pol. (H/V)
802.11n HT40 CH 38 5190MHz		10380	45.91	-28.09	74	46.6	39.61	17.13	57.43	100	0	P	H
		15570	43.5	-30.5	74	42.1	38.22	21.64	58.46	100	0	P	H
													H
													H
		10380	45.98	-28.02	74	46.67	39.61	17.13	57.43	100	0	P	V
		15570	44.11	-29.89	74	42.71	38.22	21.64	58.46	100	0	P	V
													V
													V
802.11n HT40 CH 46 5230MHz		10460	46.74	-27.26	74	47.1	39.72	17.22	57.3	100	0	P	H
		15690	43.76	-30.24	74	42.18	38.07	21.73	58.22	100	0	P	H
													H
													H
		10460	47.66	-26.34	74	48.02	39.72	17.22	57.3	100	0	P	V
		15690	45.37	-28.63	74	43.79	38.07	21.73	58.22	100	0	P	V
													V
													V
<b>Remark</b>	1. No other spurious found. 2. All results are PASS against Peak and Average limit line.												



Band 2 - 5250~5350MHz

WIFI 802.11a (Band Edge @ 3m)

WIFI	Note	Frequency	Level	Over	Limit	Read	Antenna	Cable	Preamp	Ant	Table	Peak	Pol.	
Ant.				Limit	Line	Level	Factor	Loss	Factor	Pos	Pos	Avg.		
1		( MHz )	( dBμV/m )	( dB )	( dBμV/m )	( dBμV )	( dB/m )	( dB )	( dB )	( cm )	( deg )	(P/A)	(H/V)	
802.11a CH 52 5260MHz		5063.15	59.26	-14.74	74	47.37	31.57	11.27	30.95	100	117	P	H	
		5016.65	46.93	-7.07	54	35.02	31.52	11.34	30.95	100	117	A	H	
	*	5262	90.93	-	-	78.76	31.77	11.35	30.95	100	117	P	H	
		5403.35	59.54	-14.46	74	46.99	31.9	11.6	30.95	100	117	P	H	
		5431.51	47.66	-6.34	54	35.04	31.93	11.64	30.95	100	117	A	H	
														H
		5066.15	59.13	-14.87	74	47.24	31.57	11.27	30.95	275	99	P	V	
		5137.25	46.97	-7.03	54	35.05	31.63	11.24	30.95	275	99	A	V	
	*	5262	85.87	-	-	73.7	31.77	11.35	30.95	275	99	P	V	
	*	5262	75.6	-	-	63.43	31.77	11.35	30.95	275	99	A	V	
		5399.5	59.8	-14.2	74	47.25	31.9	11.6	30.95	275	99	P	V	
		5451.42	47.67	-6.33	54	35.03	31.95	11.64	30.95	275	99	A	V	
802.11a CH 60 5300MHz		5099.45	59.1	-14.9	74	47.18	31.6	11.27	30.95	100	117	P	H	
		5138.3	46.94	-7.06	54	35.02	31.63	11.24	30.95	100	117	A	H	
	*	5299	90.41	-	-	78.21	31.8	11.35	30.95	100	117	P	H	
	*	5299	80.31	-	-	68.11	31.8	11.35	30.95	100	117	A	H	
		5444.16	59.82	-14.18	74	47.2	31.93	11.64	30.95	100	117	P	H	
		5429.97	47.68	-6.32	54	35.06	31.93	11.64	30.95	100	117	A	H	
		5110.85	59.51	-14.49	74	47.6	31.62	11.24	30.95	282	93	P	V	
		5131.1	46.97	-7.03	54	35.05	31.63	11.24	30.95	282	93	A	V	
	*	5298	84.62	-	-	72.42	31.8	11.35	30.95	282	93	P	V	
	*	5298	74.42	-	-	62.22	31.8	11.35	30.95	282	93	A	V	
		5443.61	59.48	-14.52	74	46.86	31.93	11.64	30.95	282	93	P	V	
		5421.5	47.65	-6.35	54	35.04	31.92	11.64	30.95	282	93	A	V	



<b>802.11a CH 64 5320MHz</b>	*	5319	90.58	-	-	78.28	31.82	11.43	30.95	100	118	P	H
	*	5319	80.36	-	-	68.06	31.82	11.43	30.95	100	118	A	H
		5397.74	60.19	-13.81	74	47.64	31.9	11.6	30.95	100	118	P	H
		5438.11	47.67	-6.33	54	35.05	31.93	11.64	30.95	100	118	A	H
													H
													H
	*	5322	84.01	-	-	71.71	31.82	11.43	30.95	279	93	P	V
	*	5322	73.74	-	-	61.44	31.82	11.43	30.95	279	93	A	V
		5382.01	61.09	-12.91	74	48.56	31.88	11.6	30.95	279	93	P	V
		5459.67	47.77	-6.23	54	35.13	31.95	11.64	30.95	279	93	A	V
													V
													V
<b>Remark</b>	1. No other spurious found. 2. All results are PASS against Peak and Average limit line.												



Band 2 5250~5350MHz

WIFI 802.11a (Harmonic @ 3m)

WIFI Ant. 1	Note	Frequency ( MHz )	Level ( dBμV/m )	Over Limit ( dB )	Limit Line ( dBμV/m )	Read Level ( dBμV )	Antenna Factor ( dB/m )	Cable Loss ( dB )	Preamp Factor ( dB )	Ant Pos ( cm )	Table Pos ( deg )	Peak Avg. ( P/A )	Pol. ( H/V )
802.11a CH 52 5260MHz		10520	46.26	-27.74	74	46.33	39.82	17.31	57.2	100	0	P	H
		15780	44.33	-29.67	74	42.62	37.97	21.79	58.05	100	0	P	H
													H
													H
		10520	47.26	-26.74	74	47.33	39.82	17.31	57.2	100	0	P	V
		15780	44.12	-29.88	74	42.41	37.97	21.79	58.05	100	0	P	V
													V
													V
802.11a CH 60 5300MHz		10600	47.55	-26.45	74	47.41	39.92	17.4	57.18	100	0	P	H
		15900	43.86	-30.14	74	41.97	37.82	21.88	57.81	100	0	P	H
													H
													H
		10600	47.94	-26.06	74	47.8	39.92	17.4	57.18	100	0	P	V
		15900	44.5	-29.5	74	42.61	37.82	21.88	57.81	100	0	P	V
													V
													V
802.11a CH 64 5320MHz		10640	47.59	-26.41	74	47.34	39.97	17.45	57.17	100	0	P	H
		15960	43.84	-30.16	74	41.83	37.74	21.94	57.67	100	0	P	H
													H
													H
		10640	47.52	-26.48	74	47.27	39.97	17.45	57.17	100	0	P	V
		15960	43.77	-30.23	74	41.76	37.74	21.94	57.67	100	0	P	V
													V
													V
Remark	1. No other spurious found. 2. All results are PASS against Peak and Average limit line.												



Band 2 5250~5350MHz

WIFI 802.11n HT40 (Band Edge @ 3m)

WIFI Ant. 1	Note	Frequency ( MHz )	Level ( dBμV/m )	Over Limit ( dB )	Limit Line ( dBμV/m )	Read Level ( dBμV )	Antenna Factor ( dB/m )	Cable Loss ( dB )	Preamp Factor ( dB )	Ant Pos ( cm )	Table Pos ( deg )	Peak Avg. ( P/A )	Pol. ( H/V )
802.11n HT40 CH 54 5270MHz		5123	59.68	-14.32	74	47.76	31.63	11.24	30.95	100	117	P	H
		5146.7	47.62	-6.38	54	35.71	31.65	11.21	30.95	100	117	A	H
	*	5270	91.04	-	-	78.87	31.77	11.35	30.95	100	117	P	H
	*	5270	80.37	-	-	68.2	31.77	11.35	30.95	100	117	A	H
		5458.24	59.95	-14.05	74	47.31	31.95	11.64	30.95	100	117	P	H
		5373.76	48.08	-5.92	54	35.64	31.87	11.52	30.95	100	117	A	H
		5046.5	58.49	-15.51	74	46.58	31.55	11.31	30.95	303	99	P	V
		5146.55	47.4	-6.6	54	35.49	31.65	11.21	30.95	303	99	A	V
	*	5270	88.46	-	-	76.29	31.77	11.35	30.95	303	99	P	V
	*	5270	77.98	-	-	65.81	31.77	11.35	30.95	303	99	A	V
		5439.54	59.98	-14.02	74	47.36	31.93	11.64	30.95	303	99	P	V
		5452.52	48.15	-5.85	54	35.51	31.95	11.64	30.95	303	99	A	V
802.11n HT40 CH 62 5310MHz		5057.3	59.56	-14.44	74	47.63	31.57	11.31	30.95	100	116	P	H
		5129.75	47.47	-6.53	54	35.55	31.63	11.24	30.95	100	116	A	H
	*	5310	84.89	-	-	72.59	31.82	11.43	30.95	100	116	P	H
	*	5310	74.44	-	-	62.14	31.82	11.43	30.95	100	116	A	H
		5442.07	59.41	-14.59	74	46.79	31.93	11.64	30.95	100	116	P	H
		5452.85	48.15	-5.85	54	35.51	31.95	11.64	30.95	100	116	A	H
		5018.6	59.12	-14.88	74	47.21	31.52	11.34	30.95	301	101	P	V
		5112.8	47.44	-6.56	54	35.53	31.62	11.24	30.95	301	101	A	V
	*	5310	82.7	-	-	70.4	31.82	11.43	30.95	301	101	P	V
	*	5310	72.07	-	-	59.77	31.82	11.43	30.95	301	101	A	V
	5420.29	60.1	-13.9	74	47.49	31.92	11.64	30.95	301	101	P	V	
	5419.74	48.17	-5.83	54	35.6	31.92	11.6	30.95	301	101	A	V	
Remark	1. No other spurious found. 2. All results are PASS against Peak and Average limit line.												





**Band 2 5250~5350MHz**

**WIFI 802.11n HT40 (Harmonic @ 3m)**

WIFI Ant. 1	Note	Frequency ( MHz )	Level ( dB $\mu$ V/m )	Over Limit ( dB )	Limit Line ( dB $\mu$ V/m )	Read Level (dB $\mu$ V)	Antenna Factor ( dB/m )	Cable Loss ( dB )	Preamp Factor ( dB )	Ant Pos ( cm )	Table Pos ( deg )	Peak Avg. (P/A)	Pol. (H/V)
802.11n HT40 CH 54 5270MHz		10540	46.91	-27.09	74	46.95	39.84	17.31	57.19	100	0	P	H
		15810	44.89	-29.11	74	43.12	37.93	21.82	57.98	100	0	P	H
													H
													H
		10540	50.07	-23.93	74	50.11	39.84	17.31	57.19	100	0	P	V
		15810	44.51	-29.49	74	42.74	37.93	21.82	57.98	100	0	P	V
													V
802.11n HT40 CH 62 5310MHz		10620	47.41	-26.59	74	47.25	39.94	17.4	57.18	100	0	P	H
		15930	44.49	-29.51	74	42.54	37.78	21.91	57.74	100	0	P	H
													H
													H
		10620	47.08	-26.92	74	46.92	39.94	17.4	57.18	100	0	P	V
		15930	45.01	-28.99	74	43.06	37.78	21.91	57.74	100	0	P	V
													V
Remark	1. No other spurious found.												
	2. All results are PASS against Peak and Average limit line.												



**Band 3 - 5470~5725MHz**

**WIFI 802.11a (Band Edge @ 3m)**

WIFI	Note	Frequency	Level	Over	Limit	Read	Antenna	Cable	Preamp	Ant	Table	Peak	Pol.	
Ant.				Limit	Line	Level	Factor	Loss	Factor	Pos	Pos	Avg.		
1		( MHz )	( dBµV/m )	( dB )	( dBµV/m )	( dBµV )	( dB/m )	( dB )	( dB )	( cm )	( deg )	( P/A )	( H/V )	
<b>802.11a CH 100 5500MHz</b>		5438	59.94	-14.06	74	47.32	31.93	11.64	30.95	100	114	P	H	
		5467.6	59.27	-9.03	68.3	46.58	31.97	11.67	30.95			P	H	
		5459.44	47.77	-6.23	54	35.13	31.95	11.64	30.95	100	114	A	H	
	*	5502	88.01	-	-	75.27	32	11.7	30.96	100	114	P	H	
		5502	77.63	-----	-----	64.89	32	11.7	30.96	100	114	A	H	
														H
			5410	59.53	-14.47	74	46.98	31.9	11.6	30.95	297	92	P	V
			5467.28	58.05	-10.25	68.3	45.36	31.97	11.67	30.95	297	92	P	V
			5432.88	47.62	-6.38	54	35	31.93	11.64	30.95	297	92	A	V
	*		5501	83.13	-	-	70.39	32	11.7	30.96	297	92	P	V
			5501	73.2	-----	-----	60.46	32	11.7	30.96	297	92	A	V
														V
<b>802.11a CH 116 5580MHz</b>		5439.6	59.51	-14.49	74	46.89	31.93	11.64	30.95	100	116	P	H	
		5461.04	59.89	-8.41	68.3	47.22	31.95	11.67	30.95	100	116	P	H	
		5459.12	47.62	-6.38	54	34.98	31.95	11.64	30.95	100	116	A	H	
	*	5578	92.71	-	-	79.85	32.1	11.74	30.98	100	116	P	H	
		5578	82.18	-----	-----	69.32	32.1	11.74	30.98	100	116	A	H	
			5756.04	60.2	-8.1	68.3	47.02	32.36	11.86	31.04	100	116	P	H
			5361.84	60.3	-13.7	74	47.86	31.87	11.52	30.95	285	98	P	V
			5465.2	58.93	-9.37	68.3	46.24	31.97	11.67	30.95	285	98	P	V
			5436.57	47.73	-6.27	54	35.11	31.93	11.64	30.95	285	98	A	V
	*		5578	90	-	-	77.14	32.1	11.74	30.98	285	98	P	V
			5578	79.14	-----	-----	66.28	32.1	11.74	30.98	285	98	A	V
			5739.56	60.88	-7.42	68.3	47.73	32.34	11.84	31.03	285	98	P	V



<b>802.11a</b> <b>CH 140</b> <b>5700MHz</b>	*	5702	88.39	-	-	75.27	32.29	11.84	31.01	100	116	P	H
		5702	78.23	-----	-----	65.11	32.29	11.84	31.01	100	116	A	H
		5752.68	61.98	-6.32	68.3	48.79	32.36	11.86	31.03	100	116	P	H
													H
													H
													H
	*	5702	84.39	-	-	71.27	32.29	11.84	31.01	278	100	P	V
		5702	74.24	-----	-----	61.12	32.29	11.84	31.01	278	100	A	V
		5730.2	60.13	-8.17	68.3	47	32.31	11.84	31.02	278	100	P	V
													V
													V
													V
<b>Remark</b>	1. No other spurious found. 2. All results are PASS against Peak and Average limit line.												



Band 3 - 5470~5725MHz

WIFI 802.11a (Harmonic @ 3m)

WIFI Ant. 1	Note	Frequency ( MHz )	Level ( dBμV/m )	Over Limit ( dB )	Limit Line ( dBμV/m )	Read Level ( dBμV )	Antenna Factor ( dB/m )	Cable Loss ( dB )	Preamp Factor ( dB )	Ant Pos ( cm )	Table Pos ( deg )	Peak Avg. ( P/A )	Pol. ( H/V )
802.11a CH 100 5500MHz		11000	48.23	-25.77	74	47.07	40.4	17.86	57.1	100	0	P	H
		16500	44.21	-29.79	74	38.49	39.3	22.42	56	100	0	P	H
													H
													H
		11000	48.18	-25.82	74	47.02	40.4	17.86	57.1	100	0	P	V
		16500	44.02	-29.98	74	38.3	39.3	22.42	56	100	0	P	V
													V
													V
802.11a CH 116 5580MHz		11160	50.24	-23.76	74	49.23	40.3	18.04	57.33	100	0	P	H
		16740	46.71	-27.29	74	40.13	40.07	22.65	56.14	100	0	P	H
													H
													H
		11160	56.49	-17.51	74	55.48	40.3	18.04	57.33	112	60	P	V
		11160	41.36	-12.64	54	40.35	40.3	18.04	57.33	112	60	A	V
		16740	46.49	-27.51	74	39.91	40.07	22.65	56.14	100	0	P	V
													V
802.11a CH 140 5700MHz		11400	46.69	-27.31	74	45.88	40.16	18.31	57.66	100	0	P	H
		17100	47.64	-26.36	74	40.09	41.22	22.99	56.66	100	0	P	H
													H
													H
		11400	46.34	-27.66	74	45.53	40.16	18.31	57.66	100	0	P	V
		17100	47.76	-26.24	74	40.21	41.22	22.99	56.66	100	0	P	V
													V
													V
Remark	1. No other spurious found. 2. All results are PASS against Peak and Average limit line.												



**Band 3 - 5470~5725MHz**

**WIFI 802.11n HT40 (Band Edge @ 3m)**

WIFI Ant. 1	Note	Frequency ( MHz )	Level ( dBμV/m )	Over Limit ( dB )	Limit Line ( dBμV/m )	Read Level ( dBμV )	Antenna Factor ( dB/m )	Cable Loss ( dB )	Preamp Factor ( dB )	Ant Pos ( cm )	Table Pos ( deg )	Peak Avg. ( P/A )	Pol. ( H/V )
802.11n HT40 CH 102 5510MHz		5008.55	59.06	-14.94	74	47.15	31.52	11.34	30.95	100	116	P	H
		5070.05	47.41	-6.59	54	35.52	31.57	11.27	30.95	100	116	A	H
	*	5510	81.34	-	-	68.6	32	11.7	30.96	100	116	P	H
	*	5510	70.53	-	-	57.79	32	11.7	30.96	100	116	A	H
		5453.18	59.68	-14.32	74	47.04	31.95	11.64	30.95	100	116	P	H
		5421.83	48.02	-5.98	54	35.41	31.92	11.64	30.95	100	116	A	H
		5012.45	59.11	-14.89	74	47.2	31.52	11.34	30.95	276	103	P	V
		5096.15	47.42	-6.58	54	35.5	31.6	11.27	30.95	276	103	A	V
	*	5510	80.5	-	-	67.76	32	11.7	30.96	276	103	P	V
	*	5510	69.49	-	-	56.75	32	11.7	30.96	276	103	A	V
		5430.08	59.56	-14.44	74	46.94	31.93	11.64	30.95	276	103	P	V
		5458.35	48.13	-5.87	54	35.49	31.95	11.64	30.95	276	103	A	V
802.11n HT40 CH 110 5550MHz		5063.6	58.83	-15.17	74	46.94	31.57	11.27	30.95	100	117	P	H
		5099.9	47.33	-6.67	54	35.41	31.6	11.27	30.95	100	117	A	H
	*	5550	86.37	-	-	73.53	32.07	11.74	30.97	100	117	P	H
	*	5550	75.44	-	-	62.6	32.07	11.74	30.97	100	117	A	H
		5400.71	59.81	-14.19	74	47.26	31.9	11.6	30.95	100	117	P	H
		5392.13	48.15	-5.85	54	35.62	31.88	11.6	30.95	100	117	A	H
		5092.25	59.29	-14.71	74	47.37	31.6	11.27	30.95	275	102	P	V
		5148.5	47.45	-6.55	54	35.54	31.65	11.21	30.95	275	102	A	V
	*	5550	85.71	-	-	72.87	32.07	11.74	30.97	275	102	P	V
	*	5550	75.26	-	-	62.42	32.07	11.74	30.97	275	102	A	V
	5432.06	59.8	-14.2	74	47.18	31.93	11.64	30.95	275	102	P	V	
	5428.1	48.23	-5.77	54	35.62	31.92	11.64	30.95	275	102	A	V	



<b>802.11n</b> <b>HT40</b> <b>CH 134</b> <b>5670MHz</b>		5059.4	58.71	-15.29	74	46.78	31.57	11.31	30.95	100	117	P	H
		5019.05	47.36	-6.64	54	35.45	31.52	11.34	30.95	100	117	A	H
	*	5670	85.57	-	-	72.52	32.24	11.82	31.01	100	117	P	H
	*	5670	75.01	-	-	61.96	32.24	11.82	31.01	100	117	A	H
		5447.02	60.32	-13.68	74	47.68	31.95	11.64	30.95	100	117	P	H
		5426.67	48.11	-5.89	54	35.5	31.92	11.64	30.95	100	117	A	H
		5037.8	59.2	-14.8	74	47.29	31.55	11.31	30.95	295	105	P	V
		5104.25	47.44	-6.56	54	35.55	31.6	11.24	30.95	295	105	A	V
	*	5670	85.29	-	-	72.24	32.24	11.82	31.01	295	105	P	V
	*	5670	74.81	-	-	61.76	32.24	11.82	31.01	295	105	A	V
		5387.73	59.11	-14.89	74	46.58	31.88	11.6	30.95	295	105	P	V
		5407.97	48.06	-5.94	54	35.51	31.9	11.6	30.95	295	105	A	V
<b>Remark</b>	1. No other spurious found. 2. All results are PASS against Peak and Average limit line.												



Band 3 - 5470~5725MHz

WIFI 802.11n HT40 (Harmonic @ 3m)

WIFI Ant. 1	Note	Frequency ( MHz )	Level ( dBμV/m )	Over Limit ( dB )	Limit Line ( dBμV/m )	Read Level ( dBμV )	Antenna Factor ( dB/m )	Cable Loss ( dB )	Preamp Factor ( dB )	Ant Pos ( cm )	Table Pos ( deg )	Peak Avg. ( P/A )	Pol. ( H/V )
802.11n HT40 CH 102 5510MHz		11020	48.16	-25.84	74	47.03	40.39	17.86	57.12	100	0	P	H
		16530	44.22	-29.78	74	38.37	39.41	22.46	56.02	100	0	P	H
													H
													H
		11020	47.26	-26.74	74	46.13	40.39	17.86	57.12	100	0	P	V
		16530	44.25	-29.75	74	38.4	39.41	22.46	56.02	100	0	P	V
													V
802.11n HT40 CH 110 5550MHz		11100	47.91	-26.09	74	46.86	40.34	17.95	57.24	100	0	P	H
		16650	45.39	-28.61	74	39.11	39.8	22.57	56.09	100	0	P	H
													H
													H
		11100	46.96	-27.04	74	45.91	40.34	17.95	57.24	100	0	P	V
		16650	44.92	-29.08	74	38.64	39.8	22.57	56.09	100	0	P	V
													V
802.11n HT40 CH 134 5670MHz		11340	47.12	-26.88	74	46.27	40.2	18.22	57.57	100	0	P	H
		17010	47.58	-26.42	74	40.08	40.95	22.91	56.36	100	0	P	H
		11340	46.59	-27.41	74	45.74	40.2	18.22	57.57	100	0	P	H
		17010	46.65	-27.35	74	39.15	40.95	22.91	56.36	100	0	P	H
		17010	46.65	-27.35	74	39.15	40.95	22.91	56.36	100	0	P	V
													V
													V
Remark	1. No other spurious found. 2. All results are PASS against Peak and Average limit line.												



Emission below 1GHz

WIFI 802.11n HT40 (LF @ 3m)

WIFI	Note	Frequency	Level	Over	Limit	Read	Antenna	Cable	Preamp	Ant	Table	Peak	Pol.	
Ant.				Limit	Line	Level	Factor	Loss	Factor	Pos	Pos	Avg.		
1		( MHz )	( dBμV/m )	( dB )	( dBμV/m )	( dBμV )	( dB/m )	( dB )	( dB )	( cm )	( deg )	( P/A )	( H/V )	
802.11n HT40 LF		59.7	30.89	-9.11	40	50.76	11.8	0.78	32.45			P	H	
		121.8	32.45	-11.05	43.5	45.77	17.68	1.43	32.43			P	H	
		233.31	37.28	-8.72	46	50.74	17.06	1.83	32.35	100	0	P	H	
		301.4	31.05	-14.95	46	41.38	19.56	2.34	32.23			P	H	
		461	31.89	-14.11	46	37.91	23.29	3.08	32.39			P	H	
		751.5	35.14	-10.86	46	35.86	27.61	3.97	32.3			P	H	
													H	
													H	
													H	
													H	
													H	
													H	
			112.89	34.27	-9.23	43.5	48.03	17.24	1.43	32.43			P	V
			206.85	39.4	-4.1	43.5	54.11	15.99	1.7	32.4	100	0	P	V
			243.84	35.3	-10.7	46	47.87	17.93	1.83	32.33			P	V
			302.1	35.7	-10.3	46	46	19.59	2.34	32.23			P	V
			528.2	33.8	-12.2	46	38.73	24.28	3.19	32.4			P	V
			951	33.92	-12.08	46	30	30.29	4.75	31.12			P	V
														V
														V
													V	
													V	
													V	
													V	
Remark	1. No other spurious found. 2. All results are PASS against limit line.													





**Note symbol**

*	<b>Fundamental Frequency</b> which can be ignored. However, the level of any unwanted emissions shall not exceed the level of the fundamental frequency.
!	Test result is <b>over limit</b> line.
P/A	<b>Peak</b> or <b>Average</b>
H/V	<b>Horizontal</b> or <b>Vertical</b>



A calculation example for radiated spurious emission is shown as below:

WIFI	Note	Frequency	Level	Over	Limit	Read	Antenna	Cable	Preamp	Ant	Table	Peak	Pol.
Ant.				Limit	Line	Level	Factor	Loss	Factor	Pos	Pos	Avg.	
1		( MHz )	( dBμV/m )	( dB )	( dBμV/m )	( dBμV )	( dB/m )	( dB )	( dB )	( cm )	( deg )	( P/A )	( H/V )
802.11b		2390	55.45	-18.55	74	54.51	32.22	4.58	35.86	103	308	P	H
CH 01													
2412MHz		2390	43.54	-10.46	54	42.6	32.22	4.58	35.86	103	308	A	H

- Level(dBμV/m) =  
Antenna Factor(dB/m) + Cable Loss(dB) + Read Level(dBμV) - Preamp Factor(dB)
- Over Limit(dB) = Level(dBμV/m) – Limit Line(dBμV/m)

**For Peak Limit @ 2390MHz:**

- Level(dBμV/m)  
= Antenna Factor(dB/m) + Cable Loss(dB) + Read Level(dBμV) - Preamp Factor(dB)  
= 32.22(dB/m) + 4.58(dB) + 54.51(dBμV) – 35.86 (dB)  
= 55.45 (dBμV/m)
- Over Limit(dB)  
= Level(dBμV/m) – Limit Line(dBμV/m)  
= 55.45(dBμV/m) – 74(dBμV/m)  
= -18.55(dB)

**For Average Limit @ 2390MHz:**

- Level(dBμV/m)  
= Antenna Factor(dB/m) + Cable Loss(dB) + Read Level(dBμV) - Preamp Factor(dB)  
= 32.22(dB/m) + 4.58(dB) + 42.6(dBμV) – 35.86 (dB)  
= 43.54 (dBμV/m)
- Over Limit(dB)  
= Level(dBμV/m) – Limit Line(dBμV/m)  
= 43.54(dBμV/m) – 54(dBμV/m)  
= -10.46(dB)

**Both peak and average measured complies with the limit line, so test result is “PASS”.**



**Band 1 5150~5250MHz**

**WIFI 802.11n HT40 (Band Edge @ 3m)**

WIFI Ant. 2	Note	Frequency ( MHz )	Level ( dBμV/m )	Over Limit ( dB )	Limit Line ( dBμV/m )	Read Level ( dBμV )	Antenna Factor ( dB/m )	Cable Loss ( dB )	Preamp Factor ( dB )	Ant Pos ( cm )	Table Pos ( deg )	Peak Avg. ( P/A )	Pol. ( H/V )
<b>802.11n HT40 CH 38 5190MHz</b>		5110.85	59.14	-14.86	74	47.23	31.62	11.24	30.95	125	65	P	H
		5030.75	47.39	-6.61	54	35.5	31.53	11.31	30.95	125	65	A	H
	*	5190	83.01	-	-	71.1	31.68	11.18	30.95	125	65	P	H
	*	5190	72.54	-	-	60.63	31.68	11.18	30.95	125	65	A	H
		5453.73	60.1	-13.9	74	47.46	31.95	11.64	30.95	125	65	P	H
		5457.47	48.2	-5.8	54	35.56	31.95	11.64	30.95	125	65	A	H
		5064.05	58.77	-15.23	74	46.88	31.57	11.27	30.95	294	75	P	V
		5074.4	47.37	-6.63	54	35.47	31.58	11.27	30.95	294	75	A	V
	*	5190	79.01	-	-	67.1	31.68	11.18	30.95	294	75	P	V
	*	5190	68.87	-	-	56.96	31.68	11.18	30.95	294	75	A	V
		5350	59.53	-14.47	74	47.11	31.85	11.52	30.95	294	75	P	V
		5401.92	48.03	-5.97	54	35.48	31.9	11.6	30.95	294	75	A	V
<b>Remark</b>	1. No other spurious found. 2. All results are PASS against Peak and Average limit line.												



**Band 1 5150~5250MHz**

**WIFI 802.11n HT40 (Harmonic @ 3m)**

WIFI Ant. 2	Note	Frequency ( MHz )	Level ( dBμV/m )	Over Limit ( dB )	Limit Line ( dBμV/m )	Read Level (dBμV)	Antenna Factor ( dB/m )	Cable Loss ( dB )	Preamp Factor ( dB )	Ant Pos ( cm )	Table Pos ( deg )	Peak Avg. (P/A)	Pol. (H/V)
802.11n HT40		10380	46.73	-27.27	74	47.42	39.61	17.13	57.43	100	0	P	H
		15570	43.89	-30.11	74	42.49	38.22	21.64	58.46	100	0	P	H
													H
													H
CH 38 5190MHz		10380	46.68	-27.32	74	47.37	39.61	17.13	57.43	100	0	P	V
		15570	43.59	-30.41	74	42.19	38.22	21.64	58.46	100	0	P	V
													V
													V
<b>Remark</b>	1. No other spurious found. 2. All results are PASS against Peak and Average limit line.												



Emission below 1GHz

WIFI 802.11n HT40 (LF @ 3m)

WIFI	Note	Frequency	Level	Over	Limit	Read	Antenna	Cable	Preamp	Ant	Table	Peak	Pol.	
Ant.				Limit	Line	Level	Factor	Loss	Factor	Pos	Pos	Avg.		
2		( MHz )	( dBμV/m )	( dB )	( dBμV/m )	( dBμV )	( dB/m )	( dB )	( dB )	( cm )	( deg )	(P/A)	(H/V)	
802.11n HT40 LF		202.53	35.82	-7.68	43.5	48.54	15.88	1.7	30.3			P	H	
		232.5	38.5	-7.5	46	49.95	16.97	1.83	30.25			P	H	
		257.34	37.49	-8.51	46	46.67	19.2	1.83	30.21			P	H	
		403.6	33.32	-12.68	46	38.39	22.27	2.68	30.02			P	H	
		523.3	42.04	-3.96	46	44.39	24.24	3.19	29.78	100	0	P	H	
		939.8	36.21	-9.79	46	30.71	30.03	4.6	29.13			P	H	
														H
														H
														H
														H
														H
														H
			202.53	32.44	-11.06	43.5	45.16	15.88	1.7	30.3			P	V
			232.5	34.69	-11.31	46	46.14	16.97	1.83	30.25			P	V
			259.77	33.5	-12.5	46	42.38	19.5	1.83	30.21			P	V
			602.4	34.3	-11.7	46	35.04	25.42	3.5	29.66			P	V
			748.7	39.03	-6.97	46	36.94	27.58	3.97	29.46	100	0	P	V
			922.3	34.98	-11.02	46	30.04	29.53	4.6	29.19			P	V
													V	
													V	
													V	
													V	
													V	
													V	
Remark	1. No other spurious found. 2. All results are PASS against limit line.													



**Note symbol**

*	<b>Fundamental Frequency</b> which can be ignored. However, the level of any unwanted emissions shall not exceed the level of the fundamental frequency.
!	Test result is <b>over limit</b> line.
P/A	<b>Peak</b> or <b>Average</b>
H/V	<b>Horizontal</b> or <b>Vertical</b>



A calculation example for radiated spurious emission is shown as below:

WIFI	Note	Frequency	Level	Over	Limit	Read	Antenna	Cable	Preamp	Ant	Table	Peak	Pol.
Ant.				Limit	Line	Level	Factor	Loss	Factor	Pos	Pos	Avg.	
2		( MHz )	( dBμV/m )	( dB )	( dBμV/m )	( dBμV )	( dB/m )	( dB )	( dB )	( cm )	( deg )	( P/A )	( H/V )
802.11b		2390	55.45	-18.55	74	54.51	32.22	4.58	35.86	103	308	P	H
CH 01													
2412MHz		2390	43.54	-10.46	54	42.6	32.22	4.58	35.86	103	308	A	H

- Level(dBμV/m) =  
Antenna Factor(dB/m) + Cable Loss(dB) + Read Level(dBμV) - Preamp Factor(dB)
- Over Limit(dB) = Level(dBμV/m) – Limit Line(dBμV/m)

**For Peak Limit @ 2390MHz:**

- Level(dBμV/m)  
= Antenna Factor(dB/m) + Cable Loss(dB) + Read Level(dBμV) - Preamp Factor(dB)  
= 32.22(dB/m) + 4.58(dB) + 54.51(dBμV) – 35.86 (dB)  
= 55.45 (dBμV/m)
- Over Limit(dB)  
= Level(dBμV/m) – Limit Line(dBμV/m)  
= 55.45(dBμV/m) – 74(dBμV/m)  
= -18.55(dB)

**For Average Limit @ 2390MHz:**

- Level(dBμV/m)  
= Antenna Factor(dB/m) + Cable Loss(dB) + Read Level(dBμV) - Preamp Factor(dB)  
= 32.22(dB/m) + 4.58(dB) + 42.6(dBμV) – 35.86 (dB)  
= 43.54 (dBμV/m)
- Over Limit(dB)  
= Level(dBμV/m) – Limit Line(dBμV/m)  
= 43.54(dBμV/m) – 54(dBμV/m)  
= -10.46(dB)

**Both peak and average measured complies with the limit line, so test result is “PASS”.**

## Appendix D. Setup Photographs

<Conducted Emission>

Mode 1

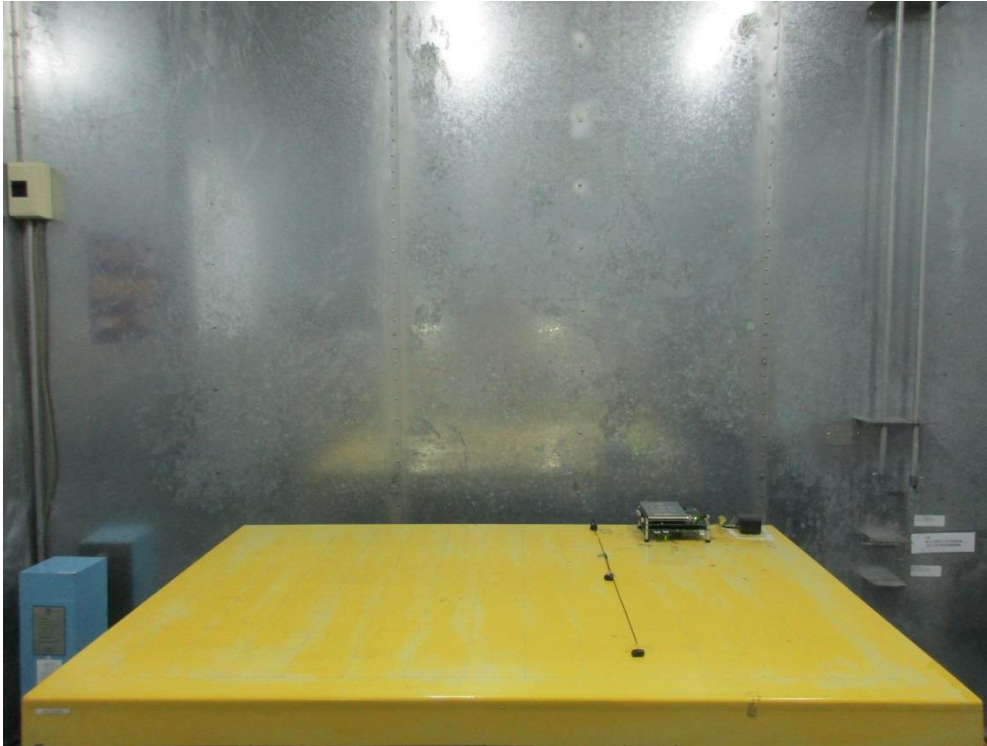



<Radiated Emission>

X Plane

LF

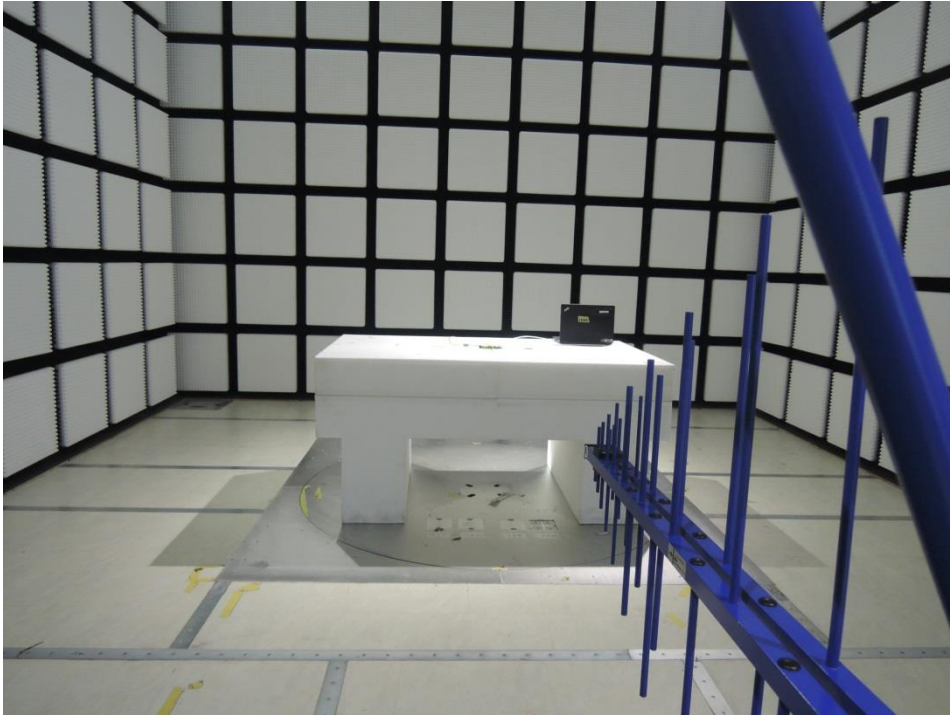

HF

