

Revision History

Rev	ECN #	Approved Date	Approved by	Notes
N/A	N/A	N/A	N/A	N/A

Place Block Diagram here (if appropriate) or delete this text box.
 If using a block diagram from another tool, save the picture as a .bmp file.
 Then, use menu Place|Drawing Tools|Graphic to insert the .png/.svg/.bmp file on the schematic.

Orderable: ChangeMe in variant	Designed for: Public Release	Mod. Date: 10/25/2021	 TEXAS INSTRUMENTS http://www.ti.com © Texas Instruments 2018
TID #: N/A	Project Title: INT174		
Number: INT174	Rev: A	Sheet Title:	
SVN Rev: Not in version control	Assembly Variant: 001	Sheet: 1 of 3	
Drawn By:	File: INT174A_CoverSheet_SchDoc	Size: B	
Engineer: Alfred Chong	Contact: http://www.ti.com/support		

Texas Instruments and/or its licensors do not warrant the accuracy or completeness of this specification or any information contained therein. Texas Instruments and/or its licensors do not warrant that this design will meet the specifications, will be suitable for your application or fit for any particular purpose, or will operate in an implementation. Texas Instruments and/or its licensors do not warrant that the design is production worthy. You should completely validate and test your design implementation to confirm the system functionality for your application.

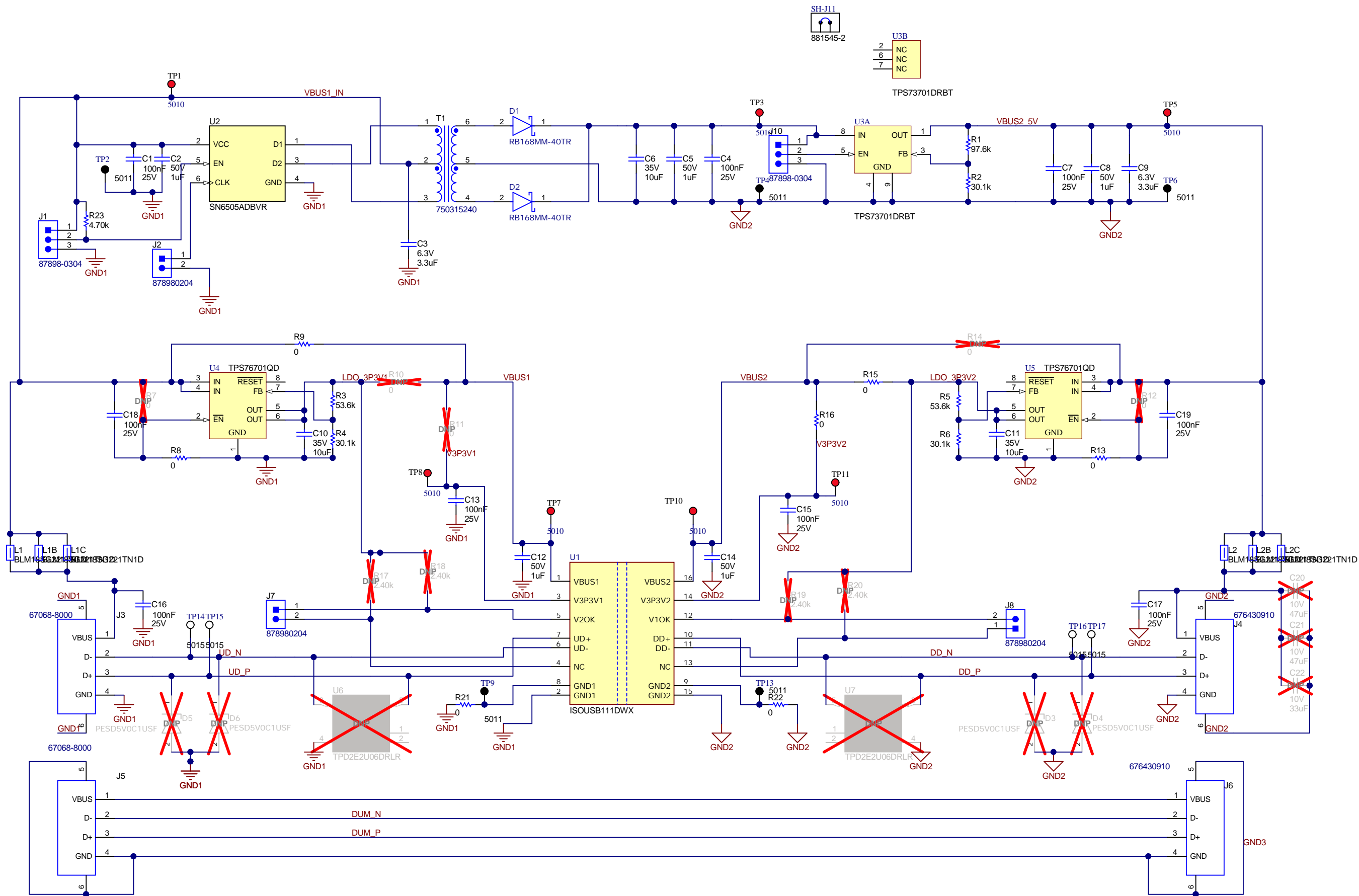

Texas Instruments and/or its licensors do not warrant the accuracy or completeness of this specification or any information contained therein. Texas Instruments and/or its licensors do not warrant that this design will meet the specifications, will be suitable for your application or fit for any particular purpose, or will operate in an implementation. Texas Instruments and/or its licensors do not warrant that the design is production worthy. You should completely validate and test your design implementation to confirm the system functionality for your application.

Orderable: ChangeMe in variant	Designed for: Public Release	Mod. Date: 11/15/2021
TID #: N/A	Project Title: INT174	
Number: INT174	Rev: A	Sheet Title: EVM_Schematic
SVN Rev: Not in version control	Assembly Variant: 001	Sheet: 2 of 3
Drawn By: Alfred Chong	File: INT174A_EVM.SchDoc	Size: B
Engineer: Alfred Chong	Contact: http://www.ti.com/support	



H9 SJ-5303 (CLEAR) H10 SJ-5303 (CLEAR) H11 SJ-5303 (CLEAR) H12 SJ-5303 (CLEAR)



PCB Number: INT174
PCB Rev: A

PCB LOGO
Texas Instruments

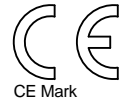

PCB LOGO
FCC disclaimer

PCB LOGO
WEEE logo

You should delete the nylon screws/standoffs and/or the bumpons as needed for your design (or substitute other parts from Hardware.IntLib). Bumpons are cheaper, but provide less clearance.

Deleting anything else from this page may result in your EVM submission being rejected (until you add them back).

Update the Label Text in the Label Table as needed for each Assembly Variant.

You should delete this note too.

Variant/Label Table	
Variant	Label Text
001	ChangeMe!
002	ChangeMe!

LBL1
PCB Label
THT-14-423-10
Size: 0.65" x 0.20 "

ZZ1
Label Assembly Note
This Assembly Note is for PCB labels only

ZZ2
Assembly Note
These assemblies are ESD sensitive, ESD precautions shall be observed.

ZZ3
Assembly Note
These assemblies must be clean and free from flux and all contaminants. Use of no clean flux is not acceptable.

ZZ4
Assembly Note
These assemblies must comply with workmanship standards IPC-A-610 Class 2, unless otherwise specified.

Orderable: ChangeMe in variant	Designed for: Public Release	Mod. Date: 10/25/2021
TID #: N/A	Project Title: INT174	
Number: INT174	Rev: A	Sheet Title:
SVN Rev: Not in version control	Assembly Variant: 001	Sheet: 3 of 3
Drawn By: Alfred Chong	File: INT174A_Hardware.SchDoc	Size: B
Engineer: Alfred Chong	Contact: http://www.ti.com/support	

Texas Instruments and/or its licensors do not warrant the accuracy or completeness of this specification or any information contained therein. Texas Instruments and/or its licensors do not warrant that this design will meet the specifications, will be suitable for your application or fit for any particular purpose, or will operate in an implementation. Texas Instruments and/or its licensors do not warrant that the design is production worthy. You should completely validate and test your design implementation to confirm the system functionality for your application.



© Texas Instruments 2018