



SANMINA

Noe Reyes <noe.reyes@sanmina.com>

Technical Evidence - Impedance Issue on Component U5

1 message

Lyvan Velazquez <lyvan.velazquez@sanmina.com>

Tue, Feb 17, 2026 at 6:06 PM

To: Noe Reyes <noe.reyes@sanmina.com>, Mauro Tostado <mauro.tostado@sanmina.com>, Adrian Bautista <adrian.bautista@sanmina.com>, David Rangel <david.rangel@sanmina.com>, Hugo RojasH <hugo.rojash@sanmina.com>, Jose Preciado M <jose.preciadom@sanmina.com>

As we discussed, I am sharing the measurement evidence for component **U5 (E51LFMDTBI-310-01004M)**.

Measurements were performed between pins 13 and 14 of U5, placing the positive probe on pin 13 and the negative probe on pin 12. The results are as follows:

- **Failed Unit:** 69 kΩ impedance.

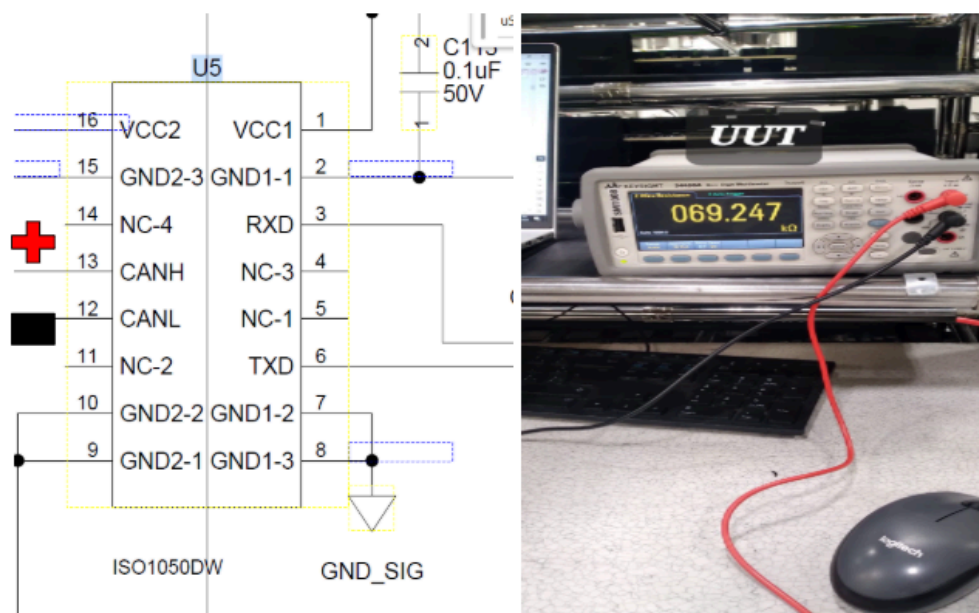

- **Good Unit (GOLDEN):** 52 kΩ impedance.

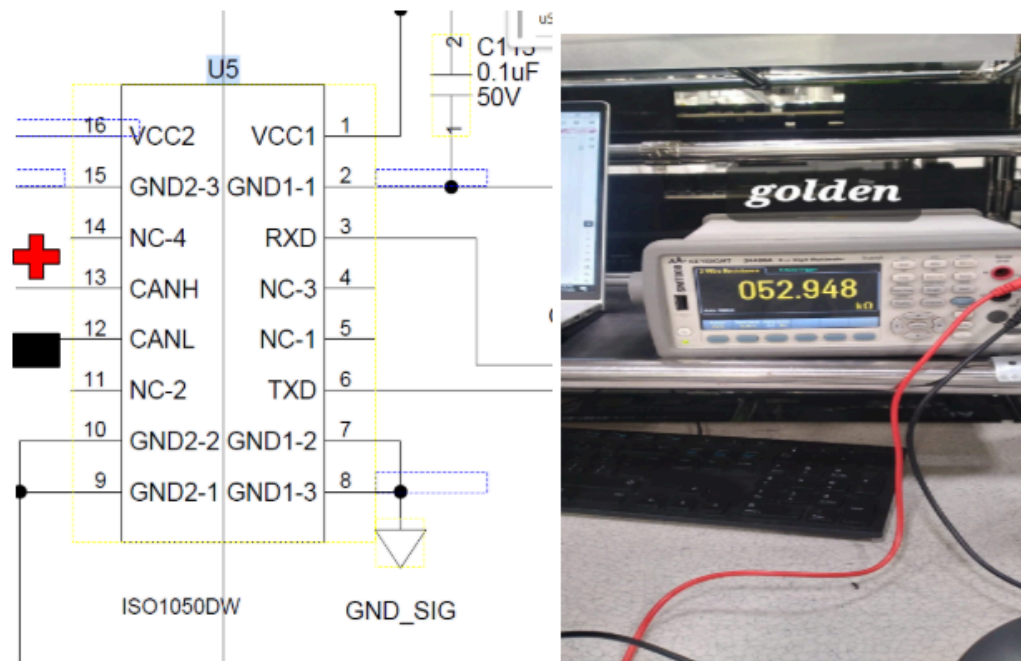

Based on these results, we have concluded that the component has an internal impedance differential, which is negatively impacting performance during the **Flying Probe test**.

I look forward to your comments.

--



SANMINA

Lyvan Velázquez Rodríguez
INGENIERO DE ANALISIS DE FALLA

Sanmina México

 Carretera Guadalajara-Chapala Km 15.5 No. 45
Guadalajara, Jalisco 45640 Mexico

 www.sanmina.com