

# **Analog Electronics Design to Improve Performance of Ultrasonic Gas Flow Meter**

*Bahram Mirshab*

## **ABSTRACT**

Transit-time ultrasonic gas flow meters have gained acceptance in applications for gas transfer distribution. Advantages of this technology include: wide measuring range, relatively high accuracy, good repeatability, negligible pressure drop, general insensitivity to liquid contaminants, insensitivity to fluctuations of the gas composition, and low maintenance.

This application note covers the operating principals of ultrasonic gas flow measurement using the TDC1000 integrated ultrasonic analog-front-end (AFE) device and the TDC7200 precision integrated timer device. It covers additional external circuitry required for boosting transducer drive pulses in gas flow meter application. The benefits of the complementary external circuits are discussed, namely driving the transducer with more energy without the requirement for inductors, and the robust filter and gain stage.

## **Contents**

1	Basics of Operation on Ultrasonic Gas Flow Sensor .....	2
2	Gas Flow Sensor Interfacing Electronics Circuits .....	4
3	Summary .....	17
4	References .....	17

## **List of Figures**

1	Ultrasonic Gas Sensor Geometry With Reflector in the Acoustic Path .....	2
2	Ultrasonic Gas Sensor Geometry With No Reflector in the Acoustic Path.....	3
3	Transmit and Receive Sequence to Measure the Difference Between the TOF for Upstream and Downstream .....	3
4	Block Diagram of the Interface Circuitry for Gas Flow Applications .....	5
5	Simplified Diagram of the TDC1000 Receiver Path.....	5
6	External Balanced Differential Transducer Driver Circuit to Increase the Excitation Energy Delivered to a Transducer.....	7
7	Output Waveform of the Differential Driver Circuit .....	8
8	Block Diagram of a Differential Transducer Driver Circuit With Sensor Interface.....	9
9	The Åckerberg-Mossberg Filter .....	11
10	AC Coupling of the Path From AM_OUT to COMPIN to Filter Offset Voltage of the Filter.....	12
11	Retrofitting TDC1000-GASEVM Board Used to Obtain Preliminary Data.....	13
12	Modification of TDC1000 Receiver Path to Include the External Filter/Gain Stage Between LNAOUT and COMPIN Pins of TDC1000.....	14
13	The Signal From a Pair of 200 kHz Audiowell Gas Transducers Placed at 8 cm Apart at the COMPIN Pin of TDC1000 .....	15
14	TDC1000 Setup Tab, Settings Not Shown in Red Font are the GUI Default Values .....	15
15	TDC1000 Tab Configuration, Settings Not Shown in Red Font is the GUI Default Values .....	16
16	TDC7200 Tab Configuration, Settings Not Shown in Red Font is the GUI Default Values .....	16
17	Normalized Delta-TOF at Zero Flow (Air) in Room Temperature for Over 14,000 Samples.....	17

All trademarks are the property of their respective owners.

**List of Tables**

1	Description of the Enquired External Passive Components .....	6
2	Signal Levels at the Receiver versus the Distance Between the Transducers, Audiowell Gas Transducer, 17 TX Pulse, 212 kHz Excitation Frequency, 3.2 V VDD and 100-kΩ Resistor in Series in TX Path to the Transducer.....	7
3	Summarized Component Values for the Åckerberg-Mossberg Topology.....	11
4	Appendix 1: Ultrasonic Gas Flow Transducer Manufacturers .....	17

**1 Basics of Operation on Ultrasonic Gas Flow Sensor**

**1.1 Ultrasonic Gas Flow Meter Sensor**

In [Figure 1](#) and [Figure 2](#) below, two types of ultrasonic gas flow sensors with different geometry are displayed. The piezoceramic transducers used in gas flow meter applications have resonance frequencies in the range of 100 kHz to 500 kHz. This frequency range provides optimal tradeoff between accuracy and signal attenuation factor in the gas medium. Traditional excitation pulses in the range of 12 V or higher are used to drive the transducers, since the attenuation of ultrasonic signal (pressure pulses) through gas medium is very large, depending on the geometry of the sensor. However, it is possible to use a lower excitation voltage to generate ultrasonic pressure pulses with the proper mechanical design of the sensor: transducers mounting geometry and optimal distance between the transducers. The Q factor, the ratio of the resonance frequency over the bandwidth, also plays an important role; higher Q factor transducers would be required.

The measurement sequence begins by transmitting and receiving acoustic pressure pulses by a pair of piezoelectric transducers, A and B, at an angle  $\theta$  with respect to the center axis of pipe.

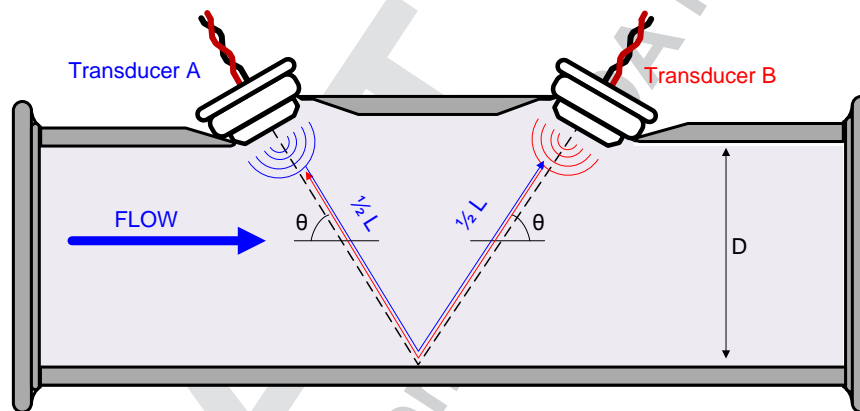

**Figure 1. Ultrasonic Gas Sensor Geometry With Reflector in the Acoustic Path**

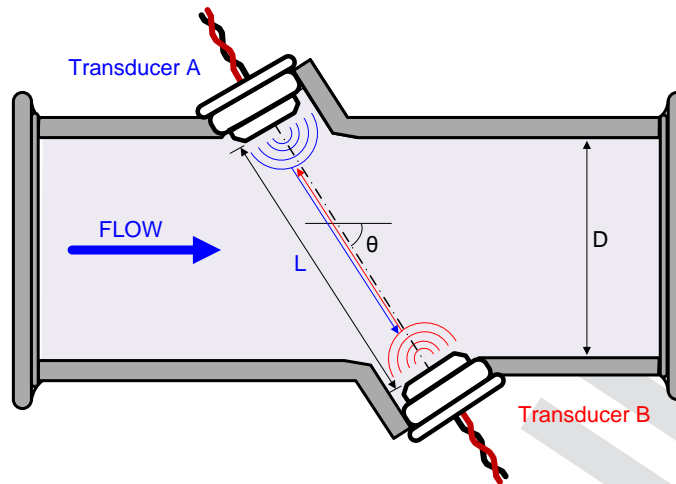

Figure 2. Ultrasonic Gas Sensor Geometry With No Reflector in the Acoustic Path

The measurement sequence of an ultrasonic flow meter is shown in Figure 3. At zero flow, the time-of-flight (TOF) for both directions is equal and the difference between  $T_{BA}$  and  $T_{AB}$  would be zero. During flow conditions, the travel time of the ultrasonic wave transmitted in the direction of the flow decreases due to velocity of moving gas. Conversely, the TOF of the pulse traveling in the opposite direction of flow increases due to the retarding effect of the flow.

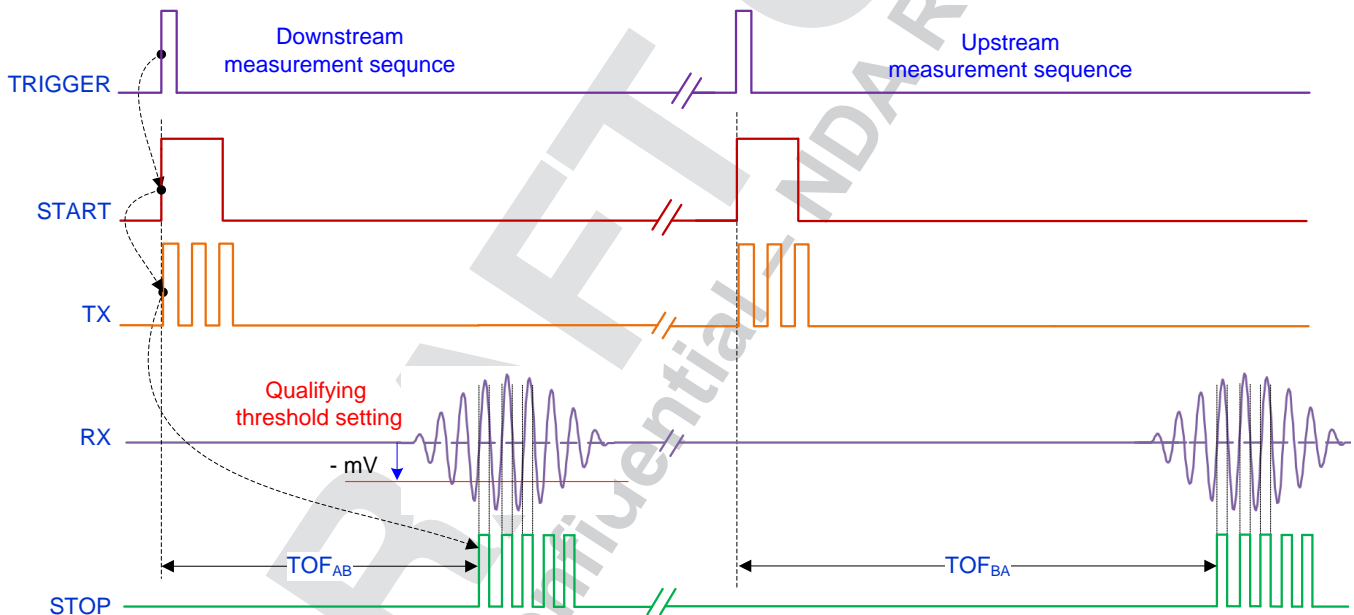

Figure 3. Transmit and Receive Sequence to Measure the Difference Between the TOF for Upstream and Downstream

## 1.2 Volumetric Flow Calculations

Transit times in the upstream and downstream directions may be calculated as:

$$T_{AB} = \left( \frac{L}{C + V \cos \theta} \right)$$

where

- C = speed of sound in the medium (about 300 m/s to 400 m/s in gas)
  - V = average velocity of the medium in the pipe
- (1)

Given the speed of sound is constant between the up and down measurement then:

$$T_{BA} = \left( \frac{L}{C - V \cos \theta} \right)$$

(2)

Using the above relation, the speed of sound can be calculated with the following equation:

$$V = \frac{L}{2 \cos \theta} \left( \frac{1}{T_{AB}} - \frac{1}{T_{BA}} \right)$$

(3)

$$C = \frac{L}{2} \left( \frac{1}{T_{AB}} + \frac{1}{T_{BA}} \right) = \frac{L}{2} \left( \frac{T_{BA} + T_{AB}}{T_{AB} \times T_{BA}} \right) = \frac{L}{2} \left( \frac{\Delta T}{T_{AB} \times T_{BA}} \right)$$

(4)

The relationship for calculating the volumetric flow rate is:

$$Q = K * V * A$$

where

- K = pipe calibration factor depending on the sensor
  - V = average velocity though of the fluid in the pipe
  - A = cross-sectional area of the meter pipe
- (5)

## 2 Gas Flow Sensor Interfacing Electronics Circuits

### 2.1 Ultrasonic Analog-Front-End and Precision Timer Circuits

As shown in [Figure 4](#), the TDC1000 UAFAE and the TDC7200 precision timer integrated devices are the primary circuitry required to interface with an ultrasonic gas flow sensor. The TDC1000 provides a programmable sensor driver and an electronic receiver for automatic sequencing of measurements. The device uses the zero-crossing technique to accurately produce and output the START and STOP pulses to be used by a precision timer to measure the TOF interval. The precision timer is required because in flow measurement application, at low flow rates the difference between the upstream and downstream TOF is extremely small, in the order of nanoseconds or hundreds of pico-seconds.

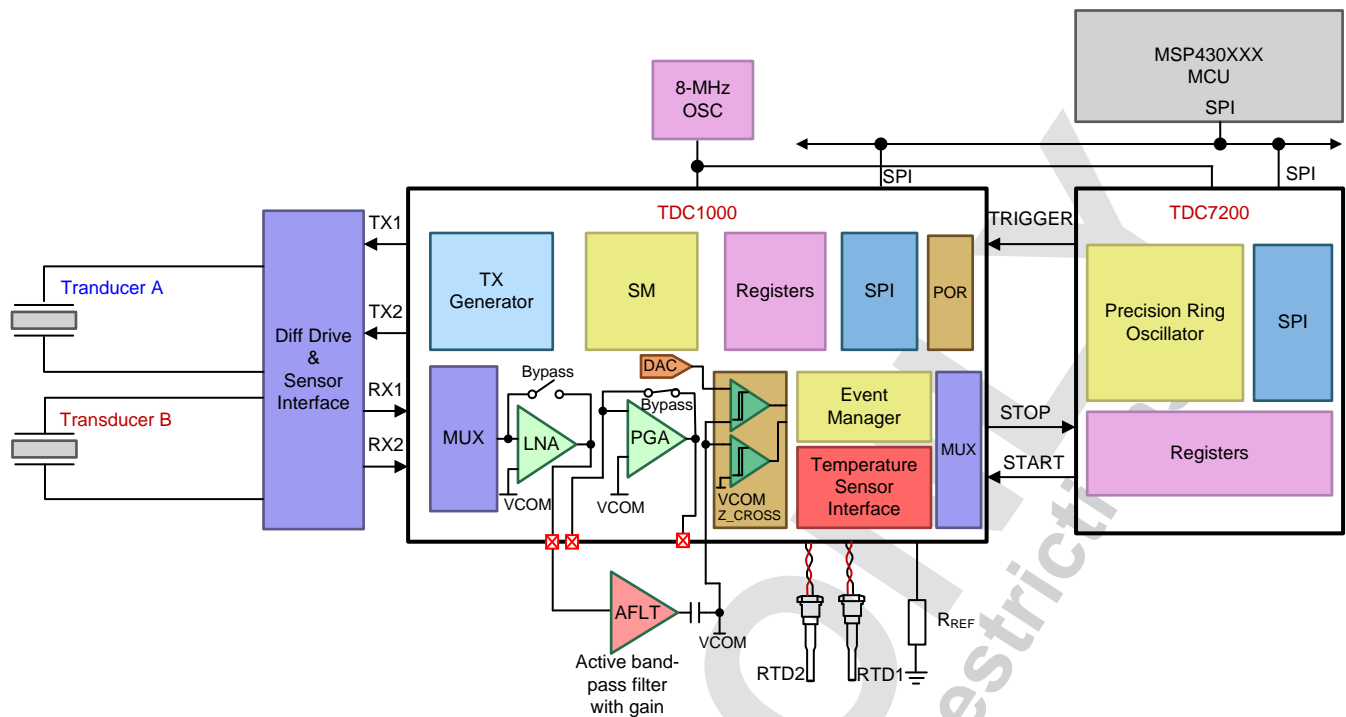

Figure 4. Block Diagram of the Interface Circuitry for Gas Flow Applications

The signal at the receiver side must be amplified because of the large attenuation of the ultrasonic signal amplitude traveling through the gas medium. The TDC1000 device includes a programmable integrated gain stage with built-in programmable on-time control feature for low-power operation. In the following section additional sensor interface circuits and external active filter circuits are described to enhance the performance of the TDC1000 UAFE device.

## 2.2 TDC1000 Receiver Signal Path

The simplified partial block diagram of the receiver path of the TDC1000 device is shown in Figure 5.

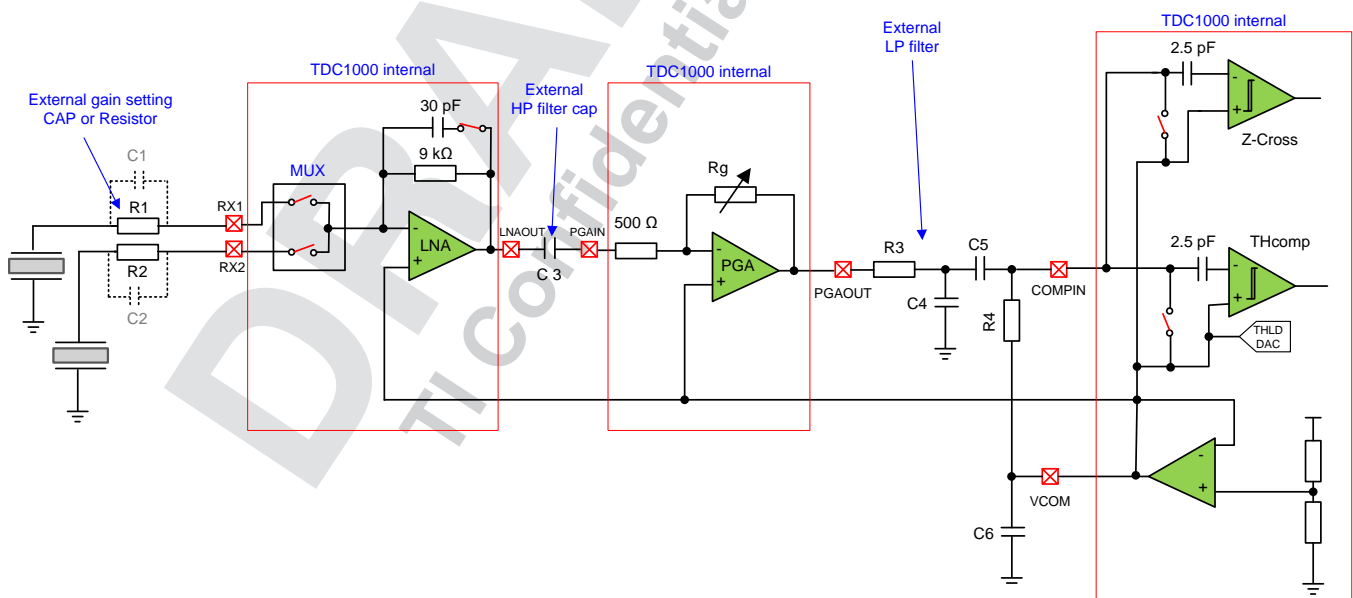

Figure 5. Simplified Diagram of the TDC1000 Receiver Path

The external required components are listed in [Table 1](#).

**Table 1. Description of the Enquired External Passive Components**

Parameter	Description	Equation	Comments
R1 and R2	LNA feedback loop gain	$G_{LNA} = \frac{9 \text{ k}\Omega}{R1 \text{ (or R2)}}$	Resistive feedback mode is intended for gas applications
C1 and C2	LNA feedback loop gain	$G_{LNA} = \frac{V_{OUT}}{V_{IN}} = \frac{s \times C1 \text{ (or C2)} \times 9 \text{ k}\Omega}{1 + s \times 30 \text{ pF} \times 9 \text{ k}\Omega}$	Capacitive feedback mode is intended for water applications
C3	High pass filter cap	$f_c = \frac{1}{2\pi \times 500 \Omega \times C3}$ ; phase shift $\phi = -\arctan \frac{1}{2\pi \times f \times 500 \Omega \times C3}$	External cap of high pass filter (combined with 500 $\Omega$ internal resistor)
R3, C4	Low pass filter	$f_c = \frac{1}{2\pi \times R3 \times C4}$ ; phase shift $\phi = -\arctan(2\pi \times R3 \times f \times C4)$	External low pass filter

The signal from a one MHz receiver transducer in a 15 to 30 mm diameter pipe containing water is typically in the range of 50 to 300 mV. For water applications the LNA should be used in capacitive feedback mode with values of C1 (and C2) equal to 300 pF. The gain of the signal at the LNA would be about 20 dB.

Unlike the water flow application, the signal in gas application from the receiver transducer is in the range of 100  $\mu$ V to 50 mV and is much smaller in amplitude than in water application. The resonant frequency of the sensor in gas flow application is typically in the 200 kHz range. Using the LNA in capacitive mode with values of C1 and C2 as given above would result in further attenuation of the signal. Much higher values of C1 and C2 could be used, but as a consequence, the LNA may go unstable under certain operating conditions. For gas applications the LNA should be operated in the resistive feedback mode. Using R1 and R2 equal to 800  $\Omega$  would provide an LNA gain of approximately 20 dB. For the low pass filter using 21 nF for C3 would set the corner frequency of the high-pass filter in the receiver path to about 15.2 kHz. The users should tune the components of the filters for best noise performance based on the resonance frequency of the particular transducers used in the application.

### 2.3 Improving Signal-To-Noise Ratio (SNR) in the Receiver

If the amplitude of the signal at the receiver side is very low (micro volt range), adding only an additional external gain stage in the receiver signal chain might not be sufficient because extensively amplifying a very weak signal would amplify the noise in the path at the same time, degrading the signal-to-noise (SNR) ratio of the receiver path. Therefore, to improve the SNR, the approach should include increasing the signal amplitude from the receiver as well as adding an additional gain circuit in the signal chain.

The signal amplitude at the receiver can be increased by applying higher energy excitation pulses to the transmitter transducer. One approach is to boost the voltage level of the transmitter by using a DC-DC boost converter of some type. In the next section we use a differential driver circuit instead to drive the transducer with more energy.

### 2.4 Increasing Transducer Excitation Energy by Means of Differential Drivers

In the application of residential gas flow meters, large energy-storing components used in the booster circuits are not desirable for obvious safety reasons. The intrinsically safe standards regulate the size of inductors and capacitors used in the gas flow meter equipment. In general, utility companies are reluctant to adopt ultrasonic gas flow meters in which inductors are utilized.

A different approach is to drive the transducer differentially, which in effect delivers double the battery voltage to the sensor. A differential driver circuit using OPA2357 is shown in Figure 6. In this circuit outputs of the TDC1000 transmitter pins are connected to the transducers through a balanced non-inverting and inverting amplifier configuration to both ends of a the transducer. In this configuration the excitation energy delivered to the transducer during transmission of excitation pulses would be approximately equivalent to the energy delivered to the transducer if it was excited with double the battery voltage in single-ended connection.

Table 2 displays the signal level at the receiver transducer when placed at different distances apart.

**Table 2. Signal Levels at the Receiver versus the Distance Between the Transducers, Audiowell Gas Transducer, 17 TX Pulse, 212 kHz Excitation Frequency, 3.2 V VDD and 100-kΩ Resistor in Series in TX Path to the Transducer**

DISTANCE BETWEEN THE TRANSDUCERS (CM)	SIGNAL AMPLITUDE SINGLE ENDED (MVP-P)	DIFFERENTIAL
8	7.62	12.47
10	6.03	10.43
12	4.79	8.61
16	2.84	5.67

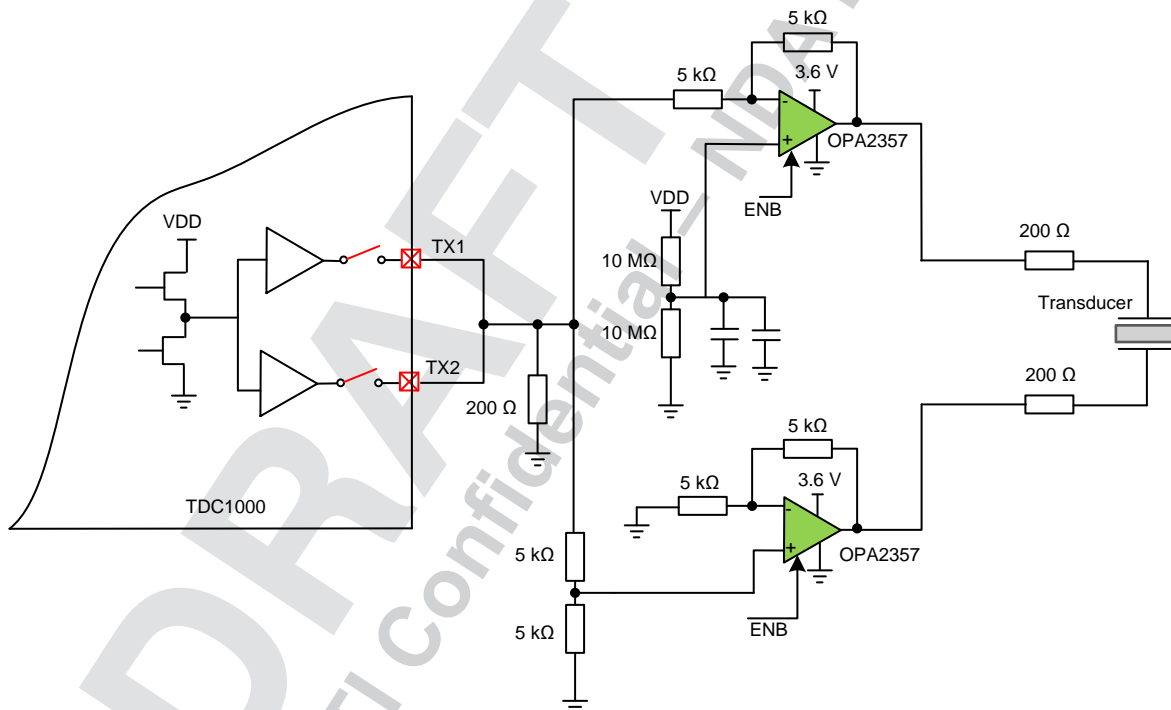

**Figure 6. External Balanced Differential Transducer Driver Circuit to Increase the Excitation Energy Delivered to a Transducer**

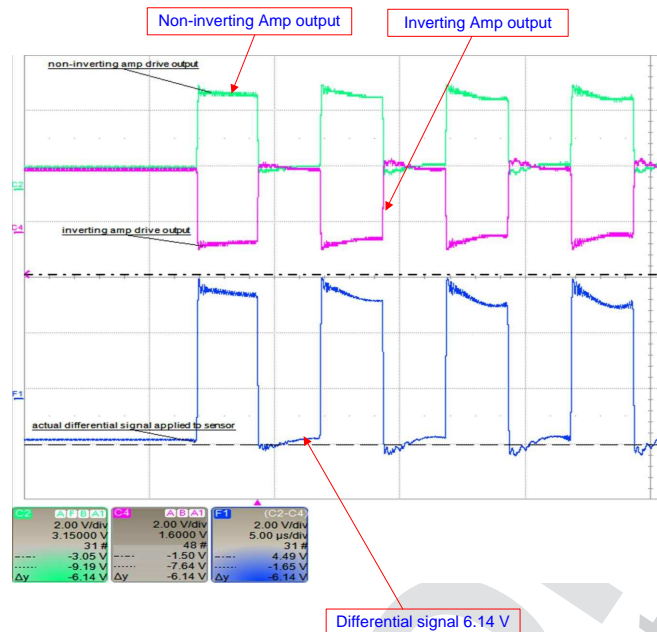

**Figure 7. Output Waveform of the Differential Driver Circuit**

The mismatch between the upstream and the downstream transducers greatly impacts the delta-TOF and the drift with temperature. This offset should be calibrated to achieve the high accuracies required at very low flow conditions. The transducer mismatch changes with the temperature, and complicates the effort of calibrating the fluctuation of the offset error. However, it is possible to minimize the effect of the mismatch of the transducers and their drift with temperature, if the transmit or receive signal path for upstream and downstream operation is very symmetrical.

There are different techniques of driving a load differentially. One approach is given in [Figure 8](#). The block diagram includes a differential driver circuit and a switch for the external sensor interface to enable driving the Transmitter transducer differentially, while allowing the receiver transducer in single-ended configuration. A more symmetrical path is achievable at a more premium cost if the TDC1000 LNA is replaced by an external LNA connected to the receiver transducer differentially. The external LNA would also increase the power consumption as the off-the-shelf devices have higher shut-down current consumption.

Referring to [Figure 8](#), during the transmission, the switches are positioned to connect the transmitter path differentially to the sensor while the receiver path is connected in single-ended configuration. As shown in the timing diagram, the phase control pin would be asserted under software control to reverse the configuration of the TX and RX direction. This configuration would require operation of the receiver path in the “short-TOF mode” to avoid floating of the receiver (unknown impedance) path at the inputs of the internal multiplexer. If the distance between the transducers in the target sensor are over 8 cm, in which case the receiver time window is insufficient to process the signal, then the user can use a resistor to ground (RT) with proper value to minimize the attenuation of the signal, which terminates the receiver when the internal multiplexer is left floating during the transmission time (see the Standard TOF measurement mode in the TDC1000 datasheet, [SNAS648](#)). An additional switch may be used to disconnect the resistor for an appropriate period of time after the START pulse. This would require connecting the START signal to an interrupt pin of the host microcontroller (MCU), and using the internal timer of the MCU for timing purposes.

In this instance a simple switching scheme was implemented by using a low-power, high-speed device from Texas instruments. However, the user can choose to implement a more elaborate set of switches to achieve a more optimal impedance matching of the TX and RX path. Make the TX/RX path as symmetrical as possible to maintain reciprocal operation. The test results of the circuit showed relatively large delta-TOF offset at zero flow, with somewhat small standard deviation over a large number of samples. The normalized graph is shown in [Figure 17](#).



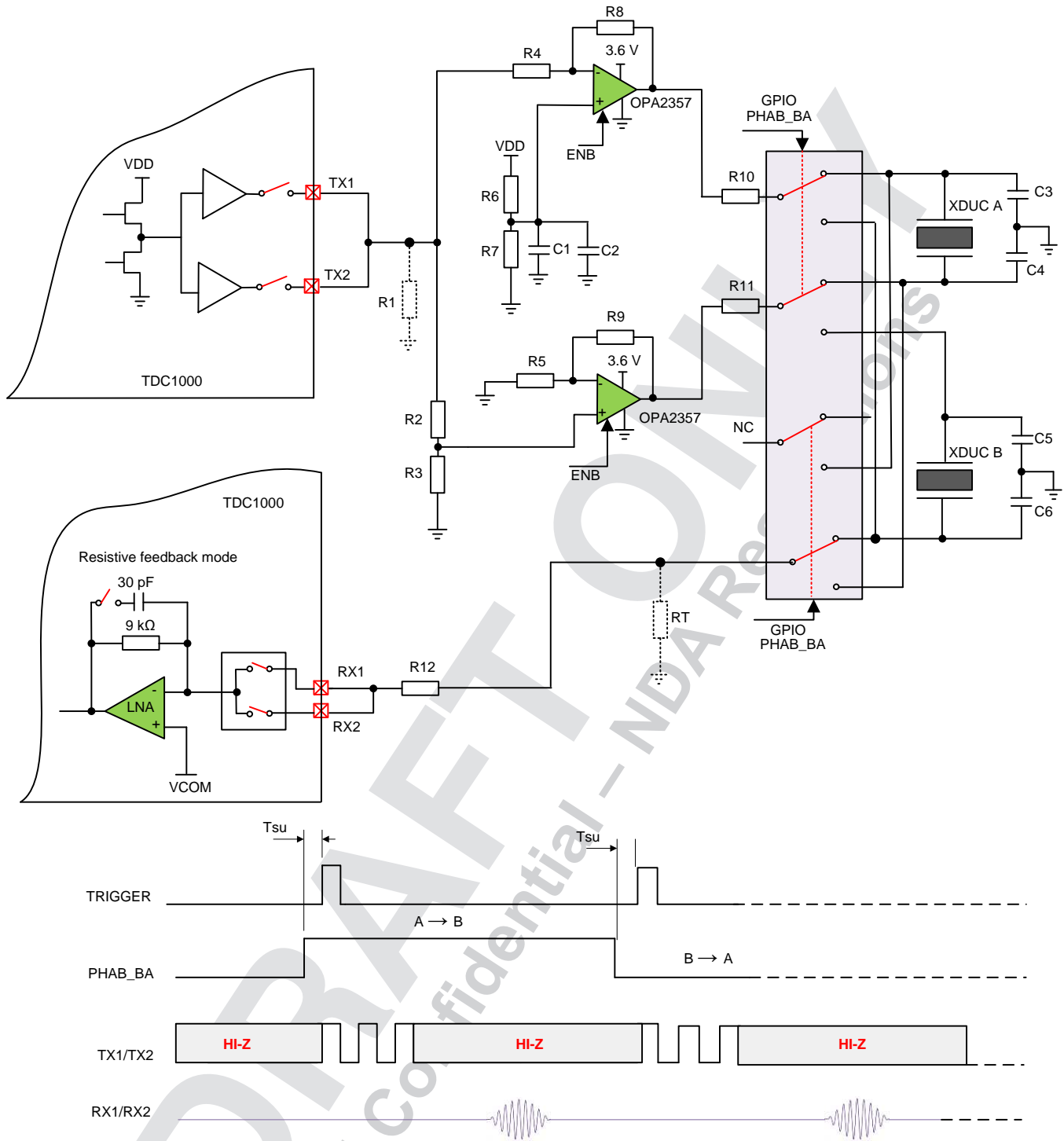

**Figure 8. Block Diagram of a Differential Transducer Driver Circuit With Sensor Interface**

The values used in the test circuit:

- $R8 = R4 = R9 = R5 = R2 = R3 = 5\text{ K}\Omega$
- $R10 = R11 = R1 = 100\ \Omega$
- $R12 = 200\ \Omega$
- $C3 = C4 = C5 = C6 = 10\text{ pF}$

## 2.5 Power Consumption Considerations

The average current consumption of the TDC1000 for a given number of settings — number of TX, receiver on time, number of averaging, and so forth — can be calculated using the link to the calculator spread sheet. For a typical single downstream/upstream measurement the combined average power consumption of the TDC1000 AFE and TDC7200 (precision timer) devices is approximately 3 to 5  $\mu\text{A}$ . With the additional external circuit mentioned above, power consumption will increase slightly. The external amplifier includes a shutdown pin for power cycling to reduce the average current consumption of the device. However, the amplifiers should to be kept in the on state during the upstream and downstream acquisition to maintain the known impedance during this period. The power consumption of the analog switch used in the external circuit is very low, making it a suitable choice for battery operated flow meter applications.

## 2.6 Implementation of an External Active Filter and Gain Stage

Important considerations include the most appropriate location in the signal chain to place the external gain stage and the key specifications required for the selection of the operational amplifier. A battery operated gas flow meter using 200-kHz transducers requires an amplifier with a shutdown pin, very low shutdown current consumption (nA range), very low offset voltage ( $\mu\text{A}$  range), sufficient bandwidth (over 1 MHz), a proper slew rate (10 V/us or higher), and relatively low voltage and current noise specifications. Finding a part with all the conditions mentioned above is a limiting factor. The two Texas Instruments devices considered in this article are the LMV881 and OPA2357 devices. The offset voltages for these amplifiers are not in the micro amp range; therefore, AC coupling is required to avoid introduction of error in delta-TOF due to the offset voltage of the selected operation amplifier.

Various active filtering topologies can be considered in the receiver signal path of the TDC1000 device for gas applications. In any case, the circuit has to meet the design goal of passing gas sensor signals in the frequency range of 100 kHz to 500 kHz and must provide enough gain to have a high-fidelity signal with peak-to-peak amplitude of about 2 V to obtain a zero-flow TOF standard deviation of a few hundred picoseconds.

The circuit was designed for a pair of 200-kHz Audiowell gas transducers. The Audiowell transducers were housed in a pipe and placed 8 cm from each other. The amplitude of signal at the receiver using the differential driver concept with twelve TX pulses of approximately 3.6 V was measured to be around 13 mV. To simplify the design, the filter stage was placed between the LNAOUT and COMPIN pins, bypassing the PGA and the filters shown in [Figure 5](#) altogether. The center frequency of the filter was designed to be about 200 kHz, with 3-dB corner frequencies of about 180 kHz and 226 kHz. Potential unwanted signals to be filtered out include 50 Hz and 60 Hz coupled from surrounding power lines, harmonics from crosstalk, and high frequency signals in the MHz and GHz range from wireless equipment used in the smart meters.

The Åckerberg-Mossberg filter shown in [Figure 9](#) is utilized. The benefit of this topology is that the center frequency can be increased to the largest resonant frequency of gas sensors without experiencing unpredictable selectivity factor Q and gain errors. A change in the center frequency does not noticeably alter the selectivity factor and gain. This permits the designer to quickly adjust to a change in the distance between the ultrasonic gas transducers as there is no complex math to be completed after the initial setup of the gain stage. In addition, a notch at any frequency below the center frequency can be designed without affecting the center frequency, mid-band gain and selectivity factor Q if required.

This topology consists of two active integrators: the inverting Miller integrator and the non-inverting integrator with active compensation. These two integrators compensate each other by reducing the errors in the selectivity factor Q due to the inherent frequency-dependent gain of non-ideal amplifier. The selectivity factor Q is crucial in gas applications where a received signal at the resonant frequency of the gas sensors is required to be amplified by at least 20 dB using the limited GBW provided by the amplifier device. Minimum selectivity factor error requires that: **START HERE**

$$C_2=C_3=C \text{ and} \tag{6}$$

$$R_3=R_6=R \tag{7}$$

Where the gas sensor resonant frequency is represented by [Equation 8](#):

$$f_0 = \frac{1}{2\pi RC} \tag{8}$$

The filter is stable if the input of the Miller integrator is fed by the negative feedback loop provided by the unity-gain inverter if:

$$R_4=R_5=R_3=R_6R.. \tag{9}$$

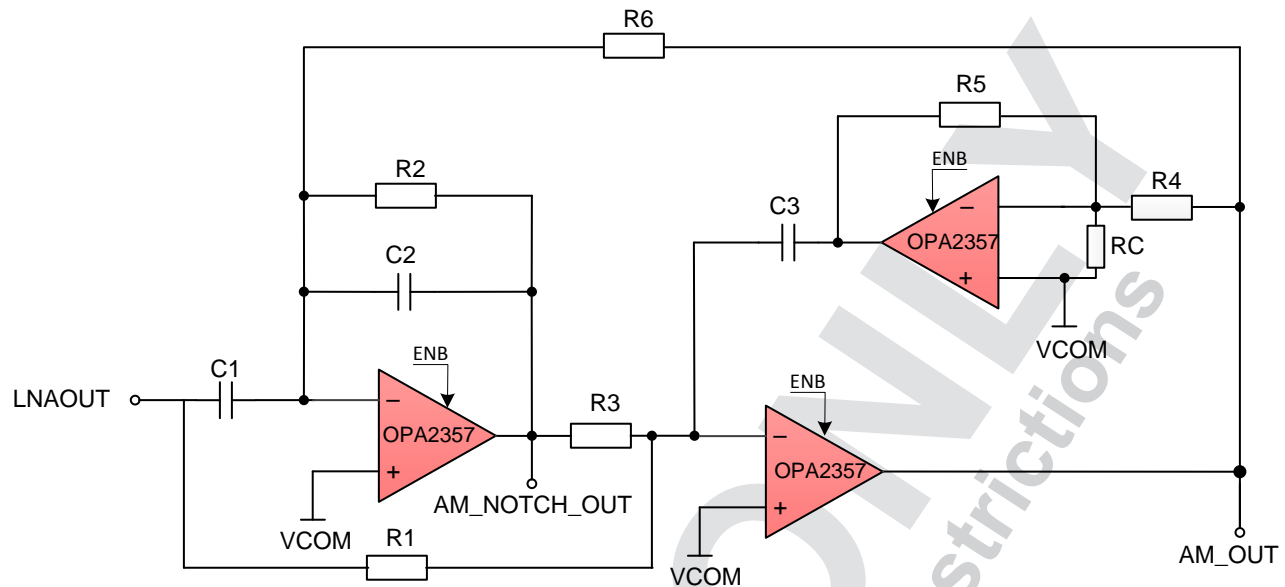

Figure 9. The Åkerberg-Mossberg Filter

The Åkerberg-Mossberg topology in Figure 9 creates an arbitrary notch via voltage feedforward that provides a clearer signal when either crosstalk or harmonics linger on the output signal. This notch does not affect the poles of the transfer function and is designed by feeding a portion of the input signal into the virtual ground node of the Miller integrator and the non-inverting integrator. It is governed by the following equation:

$$C_1=aC \text{ and } R_1=R/c. \tag{10}$$

Where:

- a Determines the high-frequency gain and
- c Determines the low-frequency gain.

The frequency of the transmission zero is represented by Equation 11:

$$f_{zero} = f_0 \sqrt{\frac{c}{a}}$$

where

- a Determines the high-frequency gain and
  - c Determines the low-frequency gain
- (11)

Resistor R<sub>2</sub> = QR sets the selectivity factor. The component values are summarized in Table 3.

Table 3. Summarized Component Values for the Åkerberg-Mossberg Topology

Component	Value	For 200kHz using FLTOUT	Description
R,C	$1/(2\pi f_0)$	795.775E-9 1/Hz	Set the cut-off frequency.
C <sub>1</sub>	aC	1 nF	Sets the high-frequency gain.
R <sub>1</sub>	R/c	7.68 kΩ	Sets the low-frequency gain.
R <sub>2</sub>	QR	25 kΩ	Sets the selectivity factor.

The designer can instead use the AM\_OUT node instead of the AM\_NOTCH\_OUT node if for whatever reason only the bandpass response is wanted. The AM\_OUT output node has an almost identical response as the AM\_NOTCH\_OUT node except for the presence of the notch at the chosen frequency. If the AM\_OUT node is used as the output, place resistor R\_C = 1.1 kΩ as shown in [Figure 9](#).

[Figure 10](#) shows the biasing circuitry to center the output signal at VCOM. AC coupling is used to filter the offset voltage of the Åckerberg-Mossberg gain stage. The cut-off frequency of the low-pass biasing circuitry (C\_out1 and R\_out1) is 40 kHz and so a gas transducer echo is not noticeably attenuated. R\_out2 stabilizes the VCOM buffer.

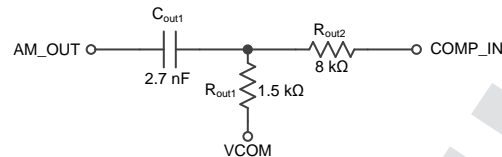

**Figure 10. AC Coupling of the Path From AM\_OUT to COMPIN to Filter Offset Voltage of the Filter**

## 2.7 Evaluation of the External Sensor Interface Using TDC1000-GASEVM

A TDC1000-GASEVM device was used for the initial evaluation of the external sensor interfacing and the active filter/gain stage. The differential driver plug-in board and the amplifier boards are shown in [Figure 11](#). The TDC1000-GASEVM device was retrofitted by completely replacing the internal PGA and the related external with active band pass filter/gain stage Modification of the TDC1000 receiver path to include the external filter/gain stage between the LNAOUT and COMPIN pins of TDC1000 shown in [Figure 12](#).

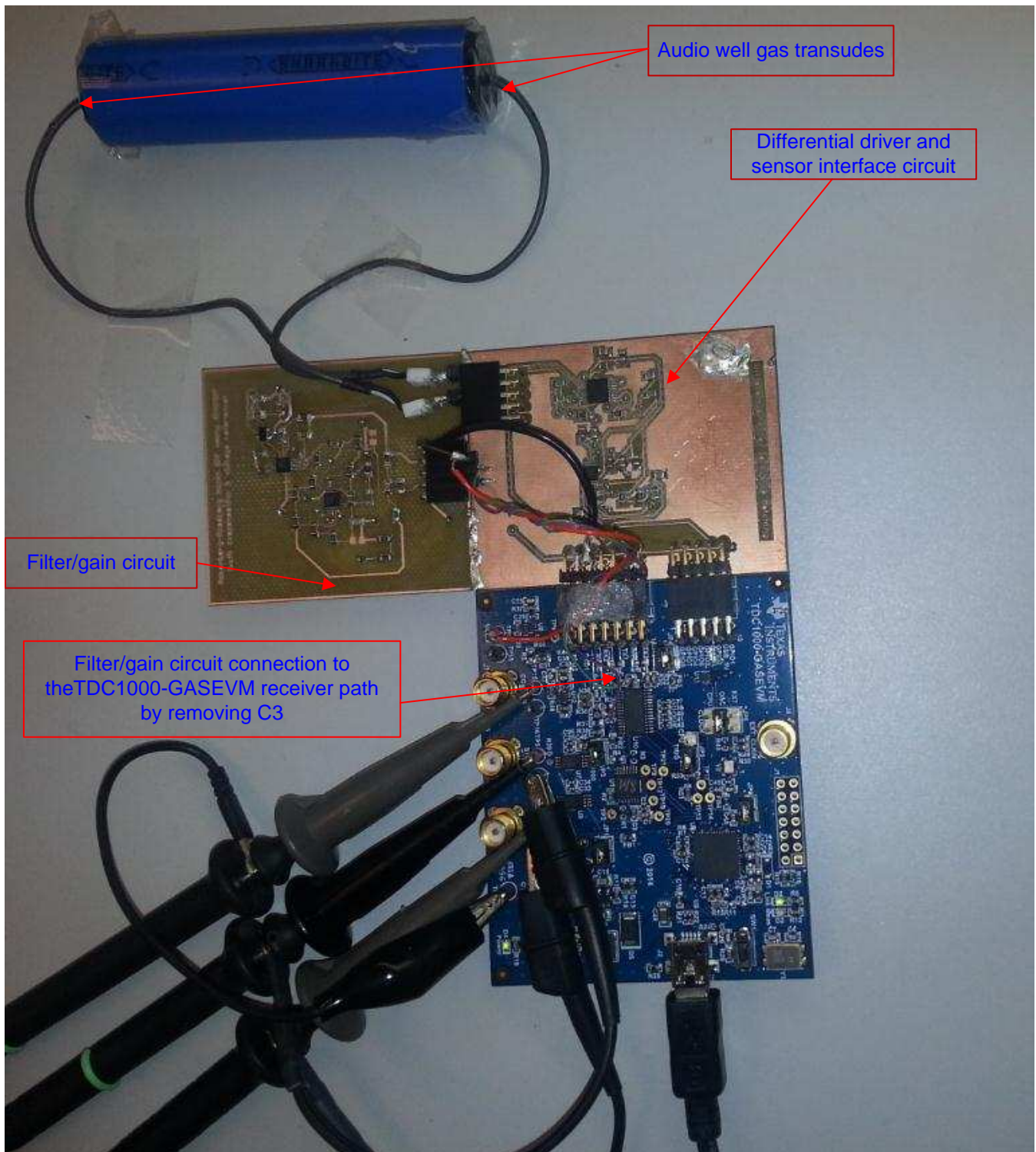

**Figure 11. Retrofitted TDC1000-GASEVM Board Used to Obtain Preliminary Data**

It is possible to include the PGA in the signal path. However, the user should not place the external gain stage between the LNA and the PGA because the input signal range of the PGA is limited to about one volt, above which it will distort the signal due to slewing condition.

This set up is intended to test the basic functionality of the external circuits, the TDC1000 device, and the TDC7200 device. To obtain high accuracy results, develop a single prototype board including the TDC1000 device, the TDC7200 device, and the external circuitry using precision passive components. Use good layout practice to have completely symmetrical input traces between sensors and the switch. The START and STOP traces between the two integrated circuits should also be placed symmetrically. The sensor connector wires should be as short as possible to minimize the delta-TOF offset. For achieving high performance, a well designed sensor with optimal distance between the transducers is required. The transducer mounting geometry is also very important because the beam from the transducers must be directed precisely to avoid offset error due to misalignment of the transducers.

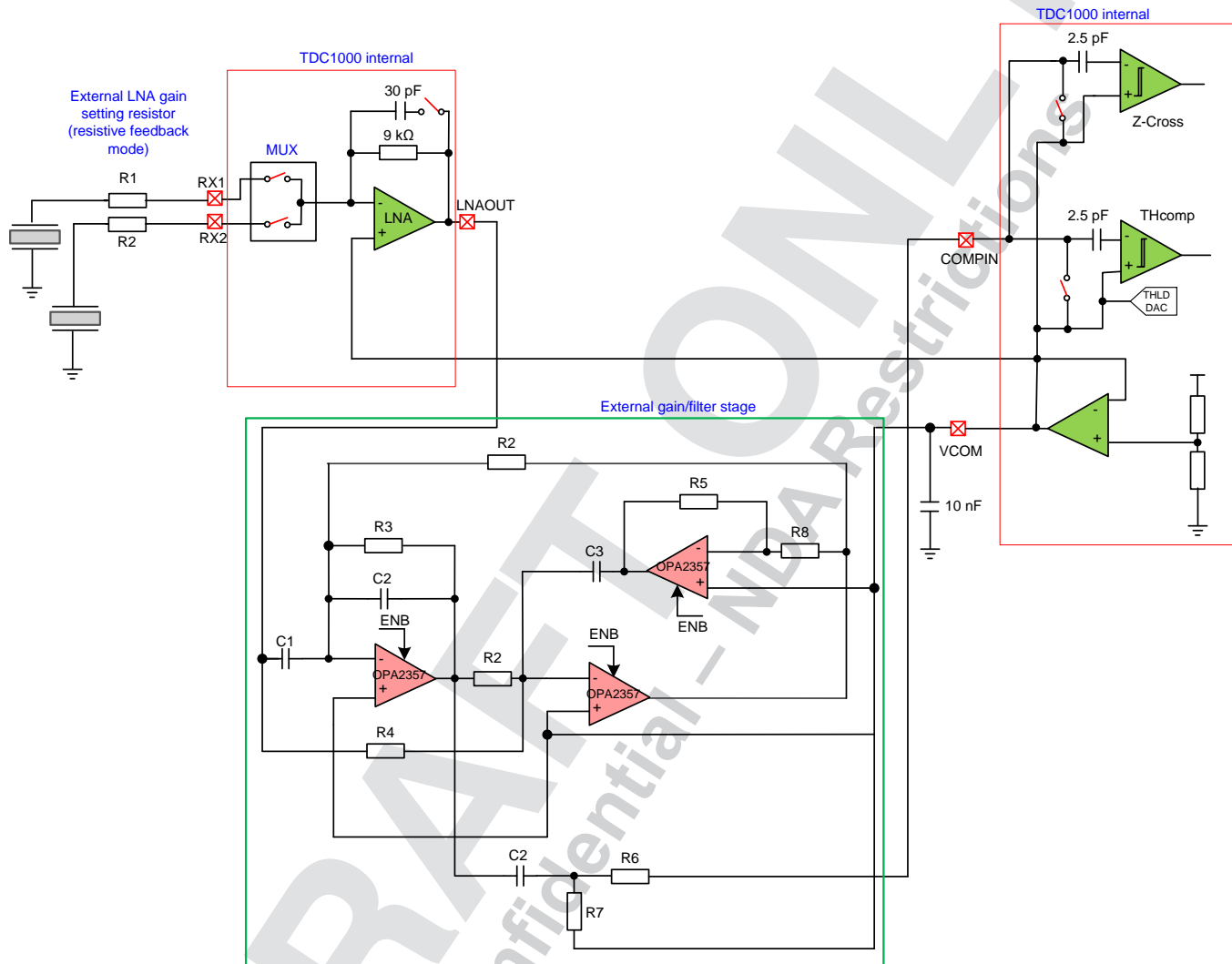

**Figure 12. Modification of TDC1000 Receiver Path to Include the External Filter/Gain Stage Between LNAOUT and COMPIN Pins of TDC1000**

Figure 13 displays the signal from a pair of Audiowell gas transducers placed in a tube, facing 8 cm from each other. The configurations of the TDC1000 and TDC7200 devices are shown in Figure 14, Figure 15, and Figure 16.

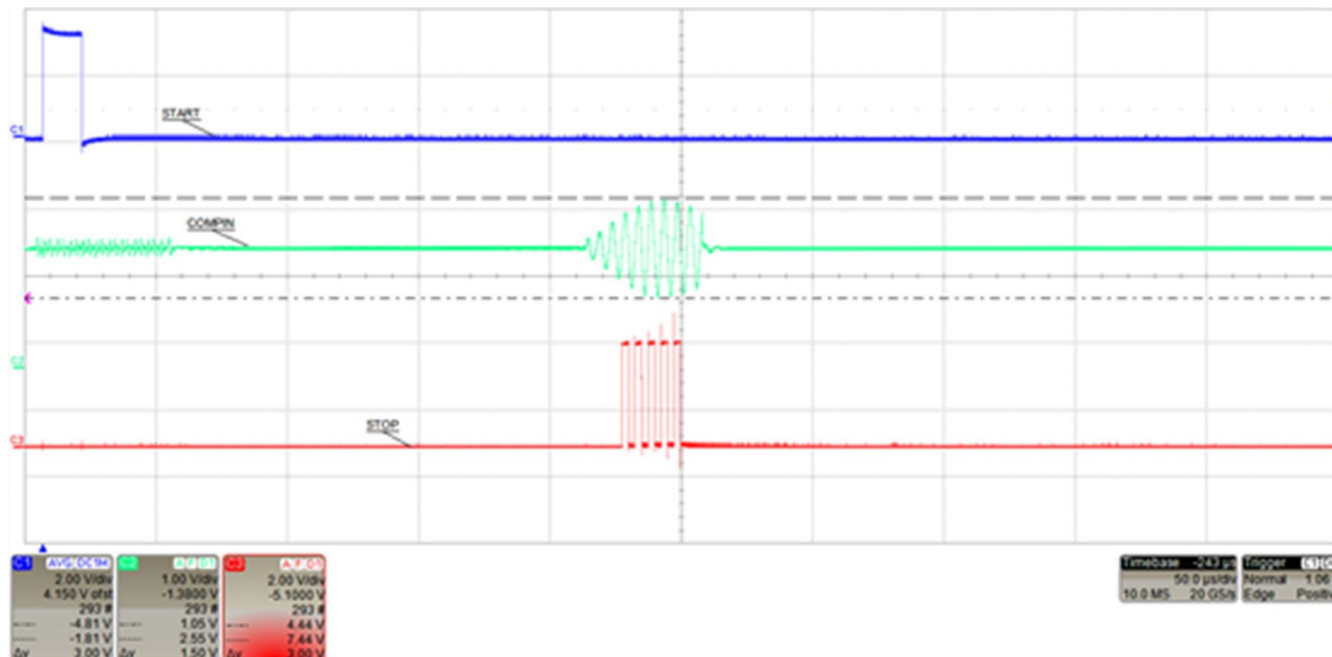

Figure 13. The Signal From a Pair of 200 kHz Audiowell Gas Transducers Placed at 8 cm Apart at the COMPIN Pin of TDC1000

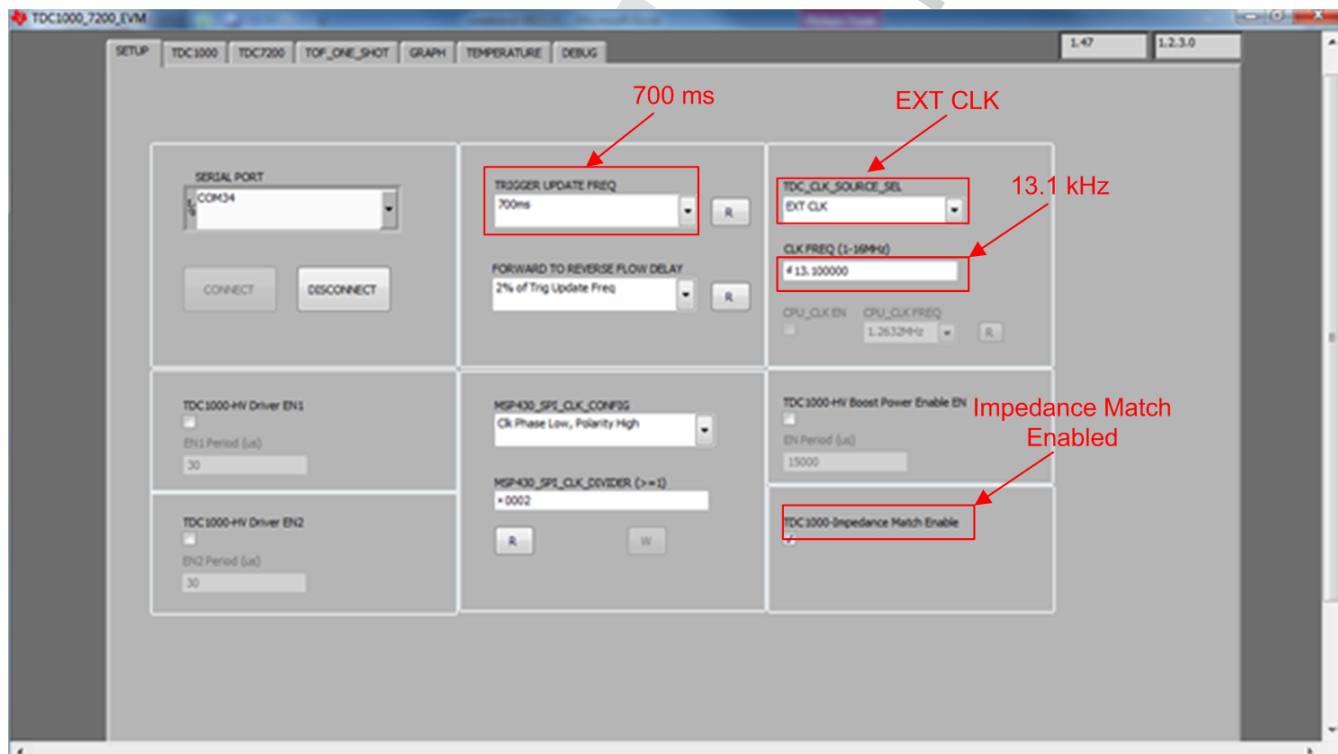

Figure 14. TDC1000 Setup Tab, Settings Not Shown in Red Font are the GUI Default Values

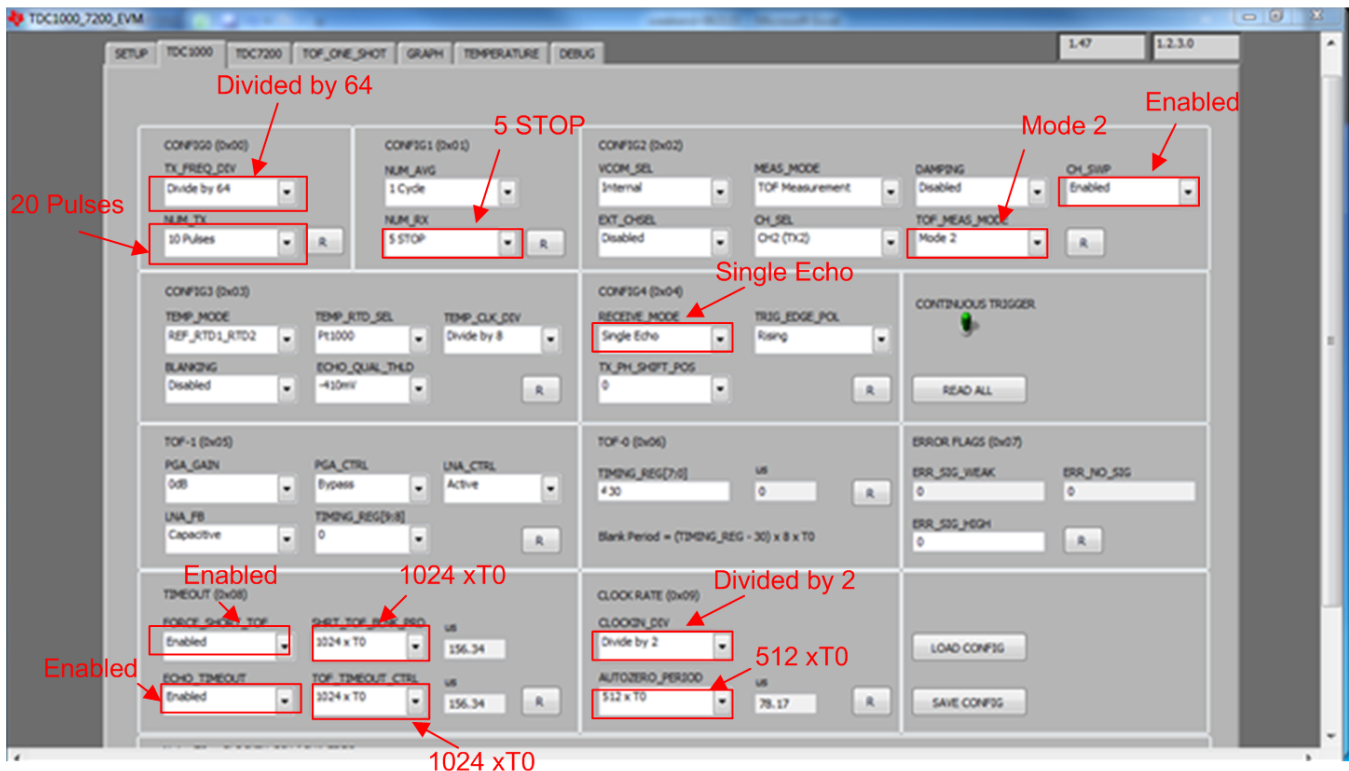

Figure 15. TDC1000 Tab Configuration, Settings Not Shown in Red Font is the GUI Default Values

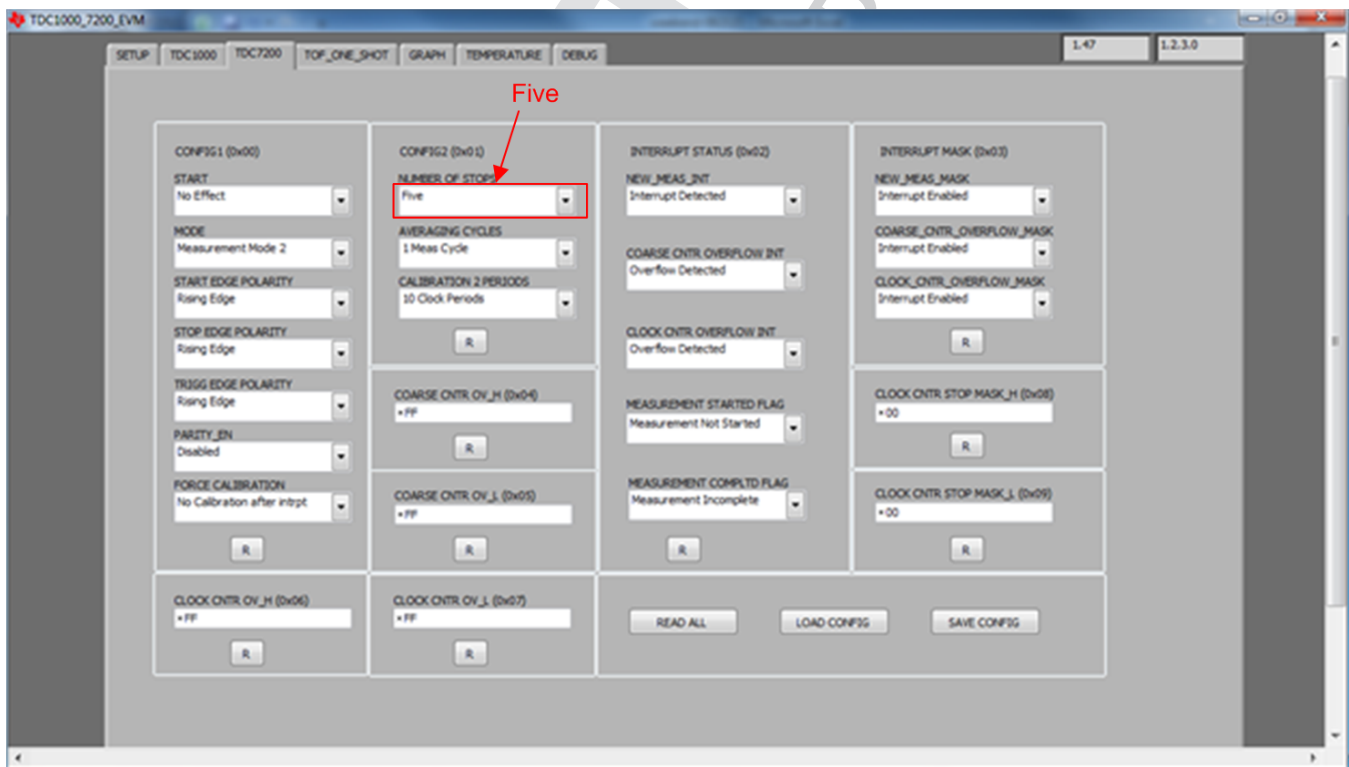

Figure 16. TDC7200 Tab Configuration, Settings Not Shown in Red Font is the GUI Default Values



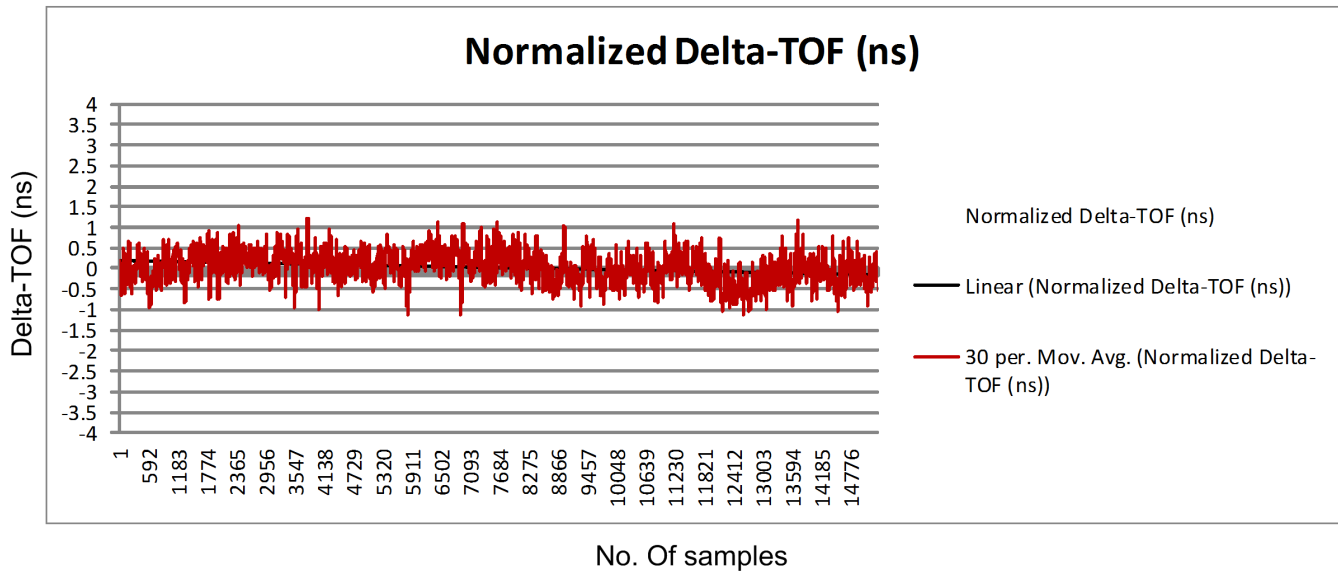

Figure 17. Normalized Delta-TOF at Zero Flow (Air) in Room Temperature for Over 14,000 Samples

### 3 Summary

In this application note the design of analog interfacing circuitry for ultrasonic gas flow transducers is presented. The solution includes the TDC1000 and the TDC7200 integrated ultrasonic interface devices with some additional external sensor interfacing, in addition to filter and gain stages. The benefits of the combined differential drive and the external filter and gain stage are presented. Some basic tests indicate that the receiver signal strength is approximately doubled when the transducer excitation pulses are applied differentially to the transmitter transducer. The plot of delta-TOF of over 140000 samples showed relatively large fixed offset. The standard deviation of the normalized delta-TOF of over 14000 samples at room temperature is approximately one nanosecond.

### 4 References

1. D. Akerberg and K. Mossberg, "A versatile active RC building block with inherent compensation for the finite bandwidth of the amplifier," IEEE Trans. on Circuits and Systems, vol. CAS-21, pp. 75-78, Jan. 1974.
2. Martin, Ken and S. Sedra, Adel, "On the Stability of the Phase-Lead Integrator," IEEE Trans. On Circuits and Systems, vol. CAS-24, NO. 6, June 1977.
3. Soderstrand, M. A. et al, "Modern Active Filter Design". John Wiley & Sons Inc. Dec 31. 1981.
4. Yang Bo n, CaoLi, " Electronic circuit design for reciprocal operation of transit-time ultrasonic flow meters"
5. Per Lunde, Magne Vestrheim, Reidar Bø, Skule Smørgrav, Atle K. Abrahamsen, "reciprocity and its utilization in ultrasonic flow meters" 23rd International North Sea Flow Measurement Workshop Tønsberg, Norway, 18 - 21 October 2005

Table 4. Appendix 1: Ultrasonic Gas Flow Transducer Manufacturers

APPLIC ATION	MANUFACTURER	TRANSDUCER PART NUMBER	LINKS	FRES (KHZ)
Gas flow	Audiowell International	AW9Y0200K02Z-01	<a href="http://www.audiowell.com/en/default.aspx">http://www.audiowell.com/en/default.aspx</a>	200
Gas flow	SECO SC125	SC125	<a href="http://www.directindustry.com/prod/seco-sensor-consult-gmbh/product-88955-903941.html">http://www.directindustry.com/prod/seco-sensor-consult-gmbh/product-88955-903941.html</a>	200

**Table 4. Appendix 1: Ultrasonic Gas Flow Transducer Manufacturers (continued)**

APPLICATION	MANUFACTURER	TRANSDUCER PART NUMBER	LINKS	FRES (KHZ)
Gas flow	Morgan	09204-00	<a href="http://www.morgantechnicalceramics.com/products/product-groups/sensors/ultrasonic-flow-sensors">http://www.morgantechnicalceramics.com/products/product-groups/sensors/ultrasonic-flow-sensors</a>	200
Gas flow	Fuji Ceramics	FUS-200A	<a href="http://www.fujicera.co.jp/product/e/03/">http://www.fujicera.co.jp/product/e/03/</a>	200
Gas flow	Murata	MA300D1 - 1	<a href="http://www.digikey.com/product-detail/en/MA300D1-1/MA300D1-1-ND/4421020">http://www.digikey.com/product-detail/en/MA300D1-1/MA300D1-1-ND/4421020</a>	300

DRAFT ONLY

TI Confidential – NDA Restrictions

## IMPORTANT NOTICE

Texas Instruments Incorporated and its subsidiaries (TI) reserve the right to make corrections, enhancements, improvements and other changes to its semiconductor products and services per JESD46, latest issue, and to discontinue any product or service per JESD48, latest issue. Buyers should obtain the latest relevant information before placing orders and should verify that such information is current and complete. All semiconductor products (also referred to herein as "components") are sold subject to TI's terms and conditions of sale supplied at the time of order acknowledgment.

TI warrants performance of its components to the specifications applicable at the time of sale, in accordance with the warranty in TI's terms and conditions of sale of semiconductor products. Testing and other quality control techniques are used to the extent TI deems necessary to support this warranty. Except where mandated by applicable law, testing of all parameters of each component is not necessarily performed.

TI assumes no liability for applications assistance or the design of Buyers' products. Buyers are responsible for their products and applications using TI components. To minimize the risks associated with Buyers' products and applications, Buyers should provide adequate design and operating safeguards.

TI does not warrant or represent that any license, either express or implied, is granted under any patent right, copyright, mask work right, or other intellectual property right relating to any combination, machine, or process in which TI components or services are used. Information published by TI regarding third-party products or services does not constitute a license to use such products or services or a warranty or endorsement thereof. Use of such information may require a license from a third party under the patents or other intellectual property of the third party, or a license from TI under the patents or other intellectual property of TI.

Reproduction of significant portions of TI information in TI data books or data sheets is permissible only if reproduction is without alteration and is accompanied by all associated warranties, conditions, limitations, and notices. TI is not responsible or liable for such altered documentation. Information of third parties may be subject to additional restrictions.

Resale of TI components or services with statements different from or beyond the parameters stated by TI for that component or service voids all express and any implied warranties for the associated TI component or service and is an unfair and deceptive business practice. TI is not responsible or liable for any such statements.

Buyer acknowledges and agrees that it is solely responsible for compliance with all legal, regulatory and safety-related requirements concerning its products, and any use of TI components in its applications, notwithstanding any applications-related information or support that may be provided by TI. Buyer represents and agrees that it has all the necessary expertise to create and implement safeguards which anticipate dangerous consequences of failures, monitor failures and their consequences, lessen the likelihood of failures that might cause harm and take appropriate remedial actions. Buyer will fully indemnify TI and its representatives against any damages arising out of the use of any TI components in safety-critical applications.

In some cases, TI components may be promoted specifically to facilitate safety-related applications. With such components, TI's goal is to help enable customers to design and create their own end-product solutions that meet applicable functional safety standards and requirements. Nonetheless, such components are subject to these terms.

No TI components are authorized for use in FDA Class III (or similar life-critical medical equipment) unless authorized officers of the parties have executed a special agreement specifically governing such use.

Only those TI components which TI has specifically designated as military grade or "enhanced plastic" are designed and intended for use in military/aerospace applications or environments. Buyer acknowledges and agrees that any military or aerospace use of TI components which have **not** been so designated is solely at the Buyer's risk, and that Buyer is solely responsible for compliance with all legal and regulatory requirements in connection with such use.

TI has specifically designated certain components as meeting ISO/TS16949 requirements, mainly for automotive use. In any case of use of non-designated products, TI will not be responsible for any failure to meet ISO/TS16949.

### Products

Audio	<a href="http://www.ti.com/audio">www.ti.com/audio</a>
Amplifiers	<a href="http://amplifier.ti.com">amplifier.ti.com</a>
Data Converters	<a href="http://dataconverter.ti.com">dataconverter.ti.com</a>
DLP® Products	<a href="http://www.dlp.com">www.dlp.com</a>
DSP	<a href="http://dsp.ti.com">dsp.ti.com</a>
Clocks and Timers	<a href="http://www.ti.com/clocks">www.ti.com/clocks</a>
Interface	<a href="http://interface.ti.com">interface.ti.com</a>
Logic	<a href="http://logic.ti.com">logic.ti.com</a>
Power Mgmt	<a href="http://power.ti.com">power.ti.com</a>
Microcontrollers	<a href="http://microcontroller.ti.com">microcontroller.ti.com</a>
RFID	<a href="http://www.ti-rfid.com">www.ti-rfid.com</a>
OMAP Applications Processors	<a href="http://www.ti.com/omap">www.ti.com/omap</a>
Wireless Connectivity	<a href="http://www.ti.com/wirelessconnectivity">www.ti.com/wirelessconnectivity</a>

### Applications

Automotive and Transportation	<a href="http://www.ti.com/automotive">www.ti.com/automotive</a>
Communications and Telecom	<a href="http://www.ti.com/communications">www.ti.com/communications</a>
Computers and Peripherals	<a href="http://www.ti.com/computers">www.ti.com/computers</a>
Consumer Electronics	<a href="http://www.ti.com/consumer-apps">www.ti.com/consumer-apps</a>
Energy and Lighting	<a href="http://www.ti.com/energy">www.ti.com/energy</a>
Industrial	<a href="http://www.ti.com/industrial">www.ti.com/industrial</a>
Medical	<a href="http://www.ti.com/medical">www.ti.com/medical</a>
Security	<a href="http://www.ti.com/security">www.ti.com/security</a>
Space, Avionics and Defense	<a href="http://www.ti.com/space-avionics-defense">www.ti.com/space-avionics-defense</a>
Video and Imaging	<a href="http://www.ti.com/video">www.ti.com/video</a>

### TI E2E Community

[e2e.ti.com](http://e2e.ti.com)