

This is the other Fet in Q13 that is unused

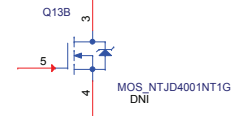

Only loaded if fans used >2.5A current
Up to 3.4A load on MAIN_12V per fan header

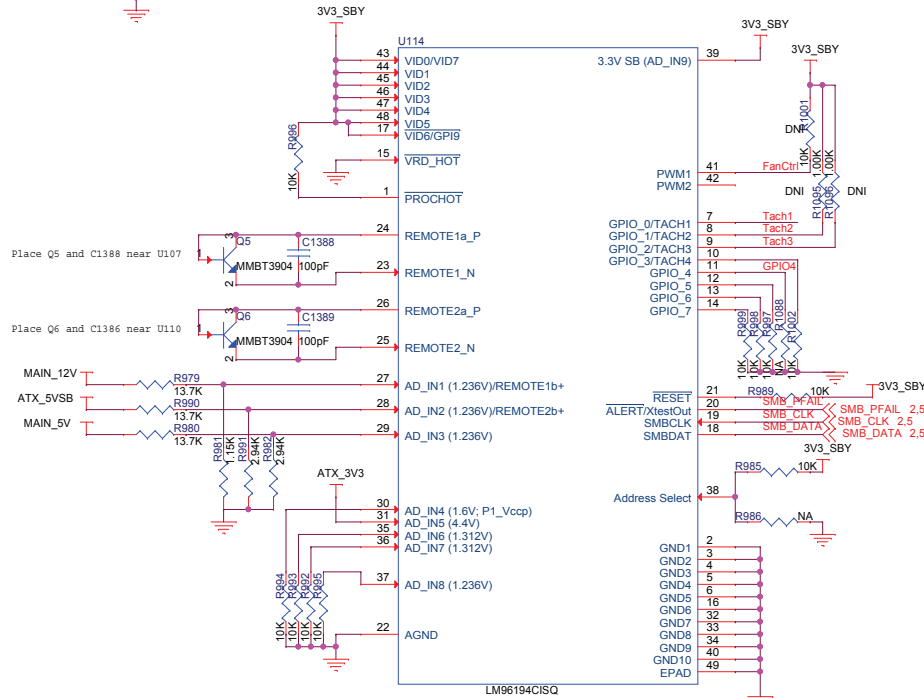
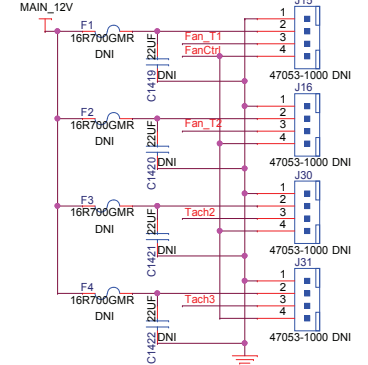

Place Q5 and C1388 near U107

Place Q6 and C1386 near U110

MAIN_12V

ATX_5VSB

MAIN_5V

ATX_3V3

LM96194CISQ

Title			Princeton System Power		
Size	Document Number				Rev
B	PCA-00852-01-D				D1
Date:	Wednesday, May 11, 2016		Sheet	5 of 5	