

BLOCK DIAGRAM

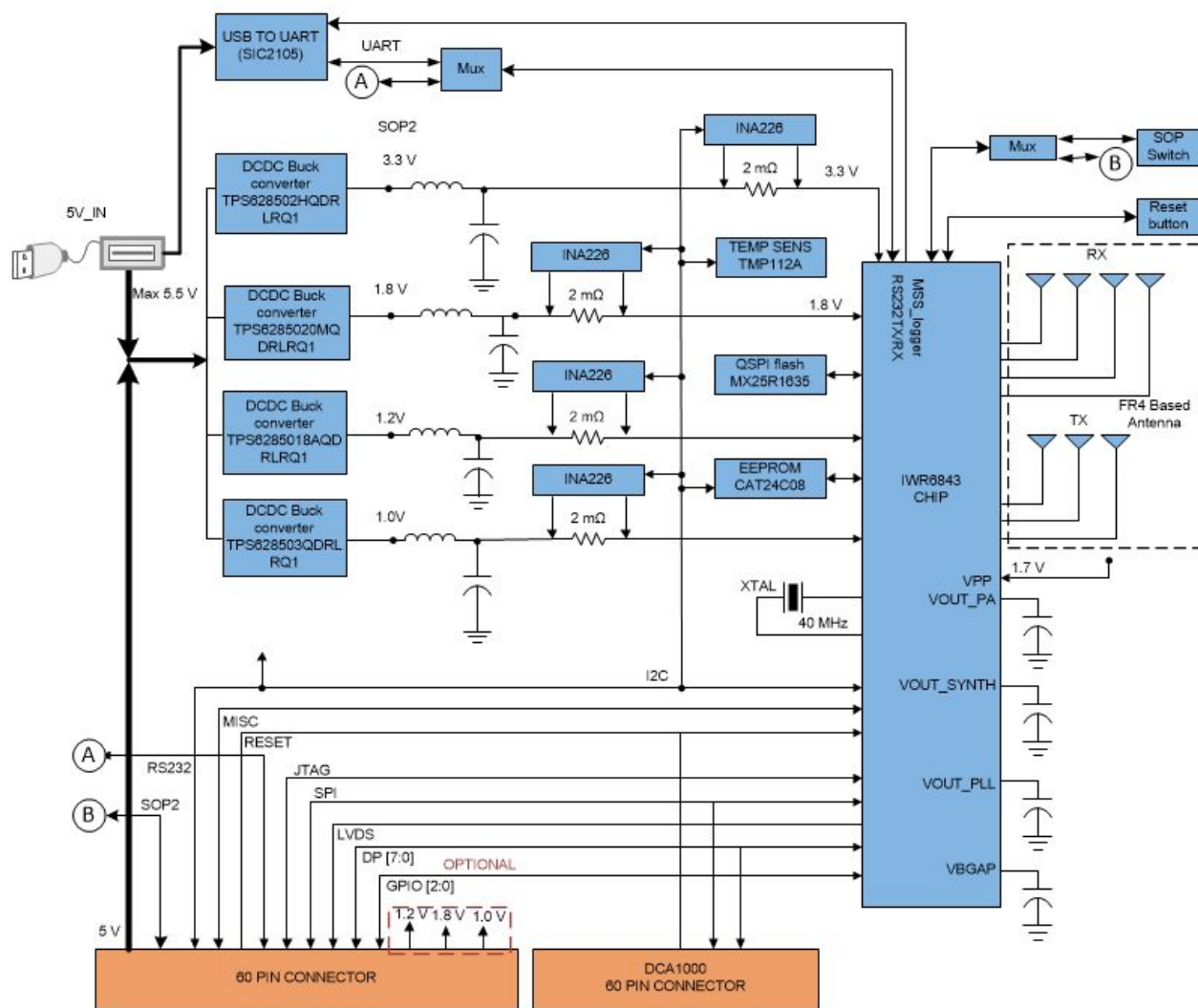

Revision History

Rev	ECN #	Approved Date	Approved by	Notes
N/A	N/A	N/A	N/A	N/A

S.No	DESCRIPTION	I2C ADDRESS
1	CURRENT SENSOR 3.3V	100 0100
2	CURRENT SENSOR 1.8V	100 0000
3	CURRENT SENSOR 1.2V	100 0001
4	CURRENT SENSOR 1.0V	100 0101
5	TEMPERATURE SENSOR1	100 1011
6	LP8770 PMIC	110 0000
7	EEPROM	1010 0XX

Texas Instruments and/or its licensors do not warrant the accuracy or completeness of this specification or any information contained therein. Texas Instruments and/or its licensors do not warrant that this design will meet the specifications, will be suitable for your application or fit for any particular purpose, or will operate in an implementation. Texas Instruments and/or its licensors do not warrant that the design is production worthy. You should completely validate and test your design implementation to confirm the system functionality for your application.

Orderable: IWR6843LCEVM	Designed for: Public Release	Mod. Date: 4/28/2021
TID #: N/A	Project Title: IWR6843 LOW COST EVM	
Number: PROC116	Rev: A	Sheet Title: BLOCK DIAGRAM
SVN Rev: Unknown revision	Assembly Variant: 001_IWR	Sheet: 1 of 14
Drawn By: Chethan Kumar.Y.B	File: PROC116A_Block_Diagram_SchDoc	Size: B
Engineer: Chethan Kumar.Y.B	Contact: http://www.ti.com/support	



© Texas Instruments 2020

TABLE OF CONTENTS

SHEET NO.	SHEET NAME
1	Block diagram
2	Table of Contents
3	DC Regulators
4	5V,PGOOD LED
5	IWR6843 Chip
6	Decoupling caps_LC_Filters
7	QSPI Flash
8	60Pin HD Connector
9	Temp_Current_Sensor
10	USB to UART
11	DCA Connector
12	SOP Control
13	CAN Interface
14	EVM Hardware

Texas Instruments and/or its licensors do not warrant the accuracy or completeness of this specification or any information contained therein. Texas Instruments and/or its licensors do not warrant that this design will meet the specifications, will be suitable for your application or fit for any particular purpose, or will operate in an implementation. Texas Instruments and/or its licensors do not warrant that the design is production worthy. You should completely validate and test your design implementation to confirm the system functionality for your application.

Orderable: IWR6843LCEVM	Designed for: Public Release	Mod. Date: 4/28/2021
TID #: N/A	Project Title: IWR6843 LOW COST EVM	
Number: PROC116	Rev: A	Sheet Title: TABLE OF CONTENTS
SVN Rev: Unknown revision	Assembly Variant: 001_IWR	Sheet: 2 of 14
Drawn By: Chethan Kumar.Y.B	File: PROC116A_Table_Of_Contents.SchDoc	Size: B
Engineer: Chethan Kumar.Y.B	Contact: http://www.ti.com/support	

DC-DC 3.3V, 1.2V, 1.8V & 1.0V OUTPUTS

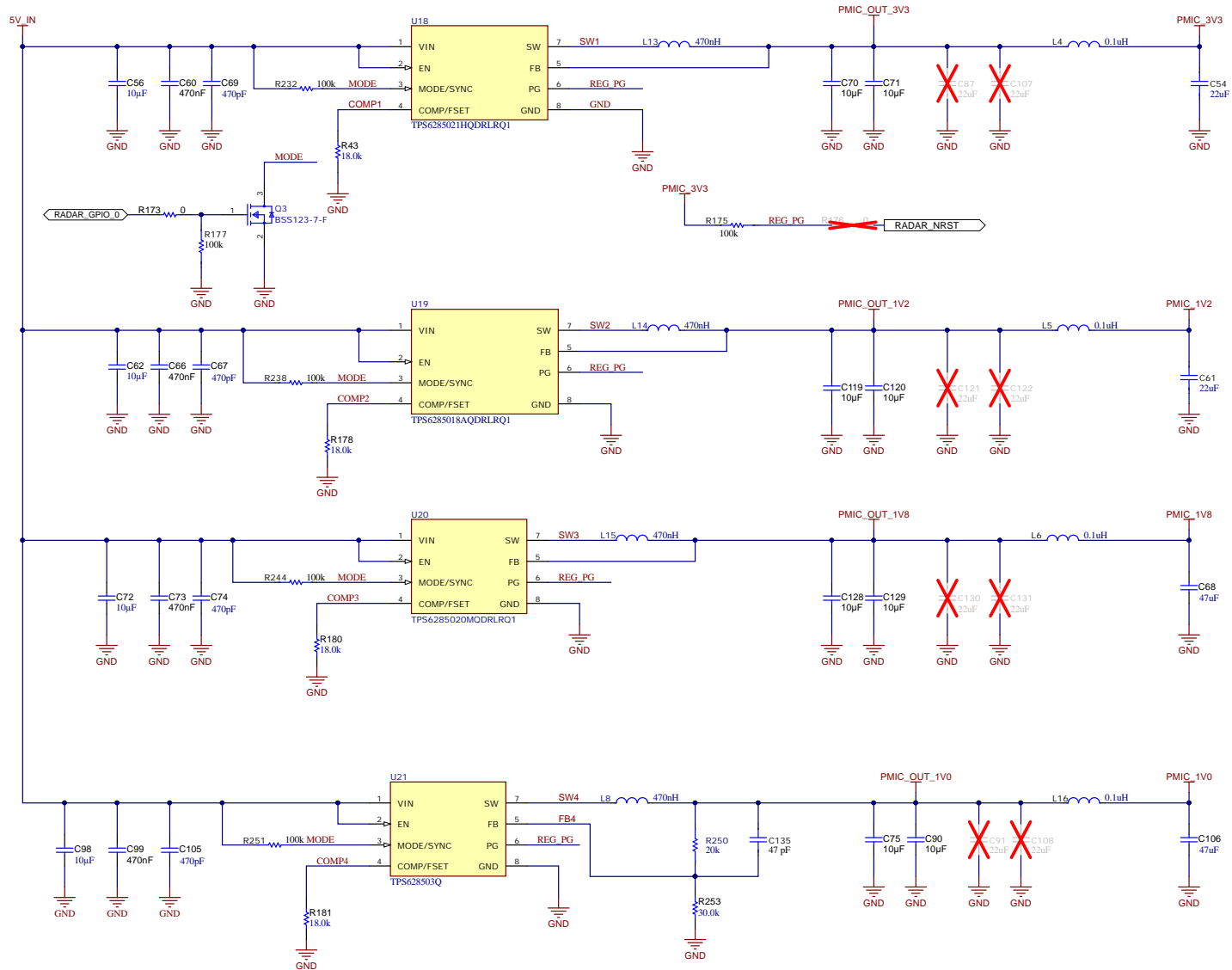

CAD NOTE :Place all input & output decaps close to Regulator Pins- U[18:21]

Texas Instruments and/or its licensors do not warrant the accuracy or completeness of this specification or any information contained therein. Texas Instruments and/or its licensors do not warrant that this design will meet the specifications, will be suitable for your application or fit for any particular purpose, or will operate in an implementation. Texas Instruments and/or its licensors do not warrant that the design is production worthy. You should completely validate and test your design implementation to confirm the system functionality for your application.

Orderable: IW/R6843LCEVM	Designed for: Public Release	Mod. Date: 4/28/2021
TID #: N/A	Project Title: IW/R6843 LOW COST EVM	
Number: PROC116	Rev: A	Sheet Title: DC_Regulators
SVN Rev: 63	Assembly Variant: 001_IWR	Sheet: 3 of 14
Drawn By: Chethan Kumar.Y.B	File: PROC116A_DC_Regulators_SchDoc	Size: B
Engineer: Chethan Kumar.Y.B	Contact: http://www.ti.com/support	

5V PWR,PGOOD LED ,Current sensors

5V LED INDICATION

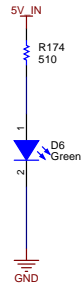
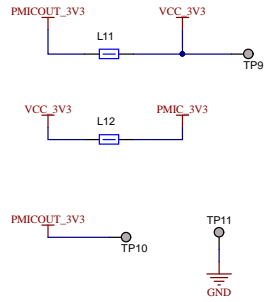

THE 3V3 OUTPUT FROM DC REGULAOTR IS USED AS PGOOD.

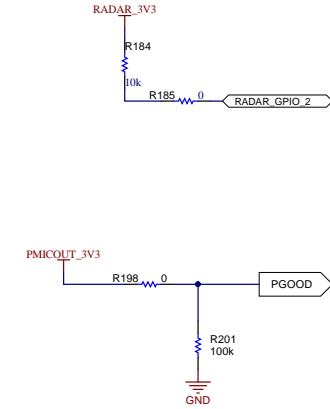
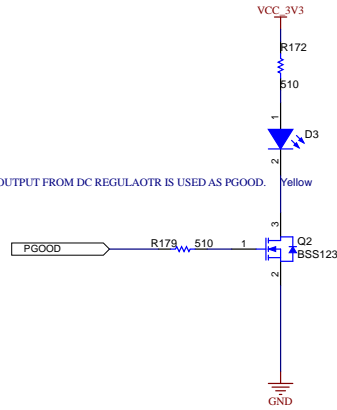

Current Sense Resistors

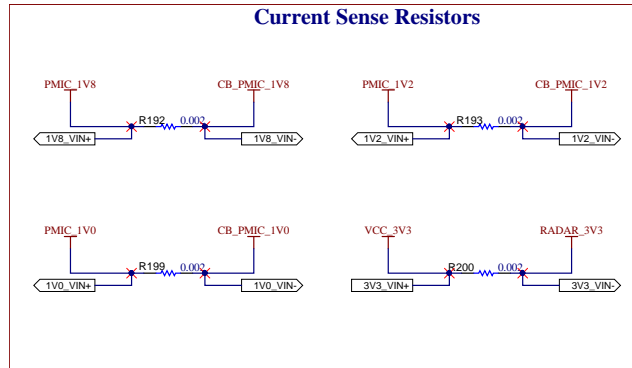

Texas Instruments and/or its licensors do not warrant the accuracy or completeness of this specification or any information contained therein. Texas Instruments and/or its licensors do not warrant that this design will meet the specifications, will be suitable for your application or fit for any particular purpose, or will operate in an implementation. Texas Instruments and/or its licensors do not warrant that the design is production worthy. You should completely validate and test your design implementation to confirm the system functionality for your application.

Orderable: IWR6843LCEVM	Designed for: Public Release	Mod. Date: 4/28/2021
TID #: N/A	Project Title: IWR6843 LOW COST EVM	
Number: PROC116	Rev: A	Sheet Title: 5V_PGOOD_LED
SVN Rev: Unknown revision	Assembly Variant: 001_IWR	Sheet: 4 of 14
Drawn By: Chethan Kumar.Y.B	File: PROC116A_5V_PGOOD_LED_SchDoc	Size: B
Engineer: Chethan Kumar.Y.B	Contact: http://www.ti.com/support	http://www.ti.com



© Texas Instruments 2020

IWR6843 Chip

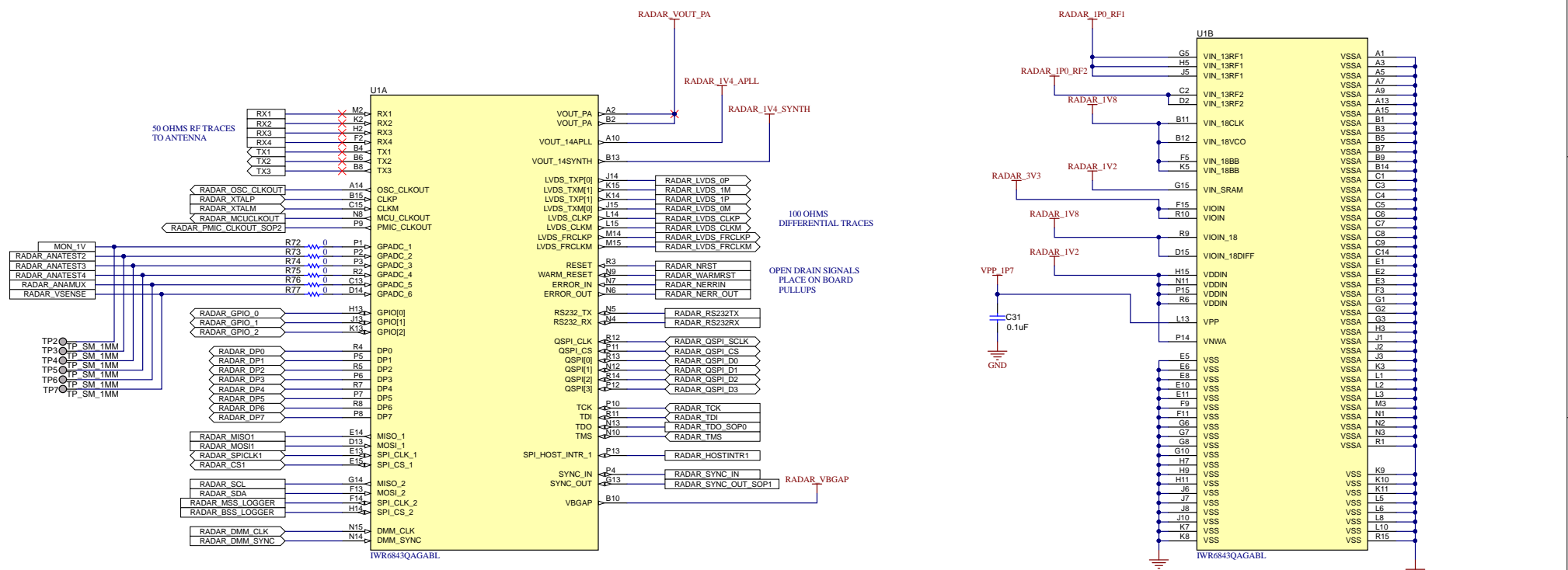

Crystal Oscillator 40MHz

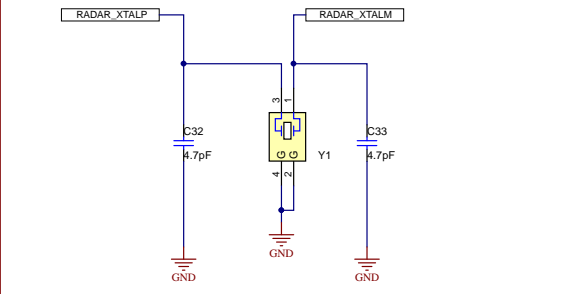

PULL UPS/DOWNS FOR SPI CS1, NERRIN, RS232, SYNC_IN & HOST_INTn

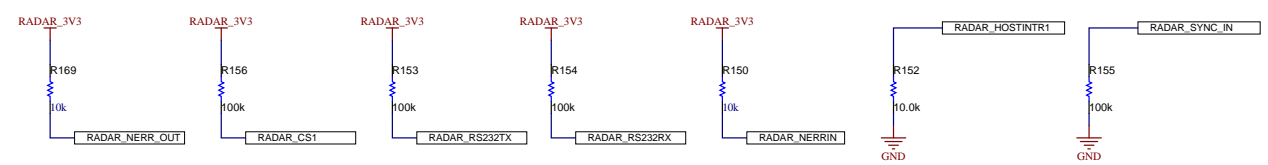

Texas Instruments and/or its licensors do not warrant the accuracy or completeness of this specification or any information contained therein. Texas Instruments and/or its licensors do not warrant that this design will meet the specifications, will be suitable for your application or fit for any particular purpose, or will operate in an implementation. Texas Instruments and/or its licensors do not warrant that the design is production worthy. You should completely validate and test your design implementation to confirm the system functionality for your application.

Orderable: IWR6843LCEVM	Designed for: Public Release	Mod. Date: 4/28/2021
TID #: N/A	Project Title: IWR6843 LOW COST EVM	
Number: PROC116	[Rev: A] Sheet Title: IWR6843_CHIP	
SVN Rev: 71 [Locally Modified]	Assembly Variant: 001_IWR	Sheet: 5 of 14
Drawn By: Chethan Kumar Y.B	File: PROC116A_IWR6843_Chip_SchDoc	Size: B
Engineer: Chethan Kumar Y.B	Contact: http://www.ti.com/support	



© Texas Instruments 2020

SUPPLY_DECOUPLING_CAPS

DCDC LC filters

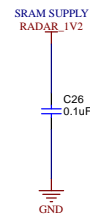
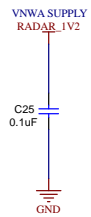
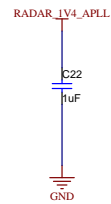
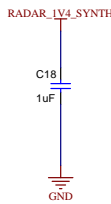
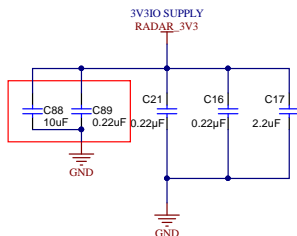
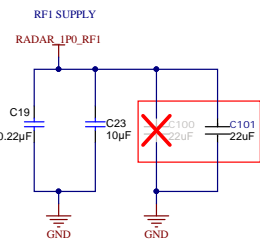
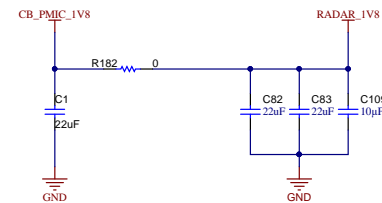
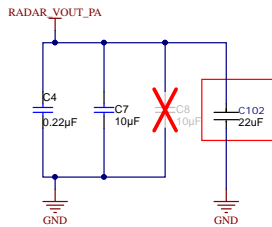
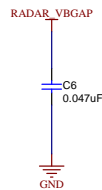
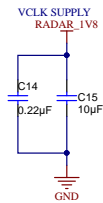
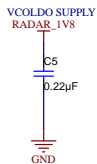
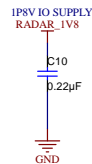
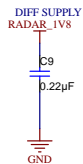
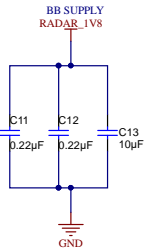

Design note: Alternate Ferrite bead part for R182,R183
BLM18KG121TH1D

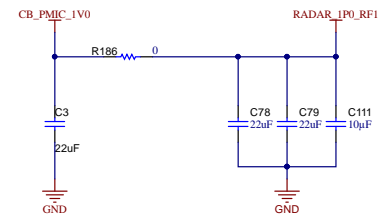
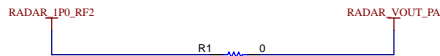
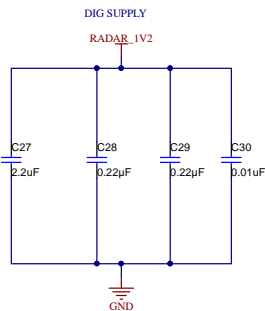
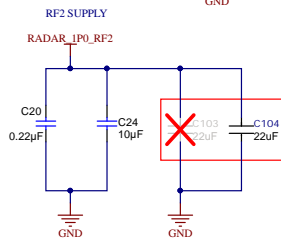
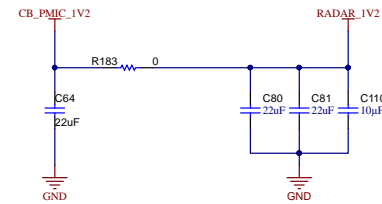

Design note: Alternate Ferrite bead part for R186,R187
BLM21PG121SH1D

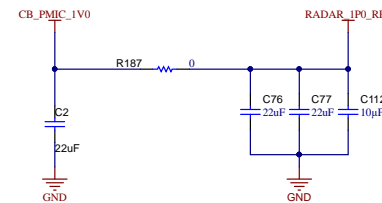

Texas Instruments and/or its licensors do not warrant the accuracy or completeness of this specification or any information contained therein. Texas Instruments and/or its licensors do not warrant that this design will meet the specifications, will be suitable for your application or fit for any particular purpose, or will operate in an implementation. Texas Instruments and/or its licensors do not warrant that the design is production worthy. You should completely validate and test your design implementation to confirm the system functionality for your application.

Orderable: IWR6843LCEVM	Designed for: Public Release	Mod. Date: 4/28/2021
TID #: N/A	Project Title: IWR6843 LOW COST EVM	
Number: PROC116	Rev: A	Sheet Title: Decoupling Caps
SVN Rev: Unknown revision	Assembly Variant: 001_IWR	Sheet: 6 of 14
Drawn By: Chethan Kumar.Y.B	File: PROC116A_Decoupling_caps_SchDoc	Size: B
Engineer: Chethan Kumar.Y.B	Contact: http://www.ti.com/support	http://www.ti.com



© Texas Instruments 2020

QSPI FLASH

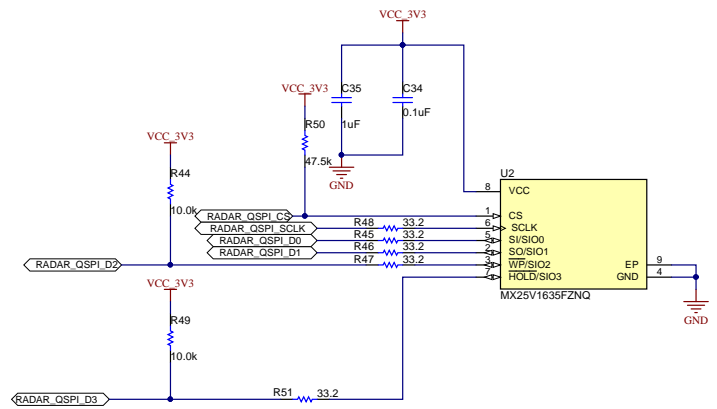

Texas Instruments and/or its licensors do not warrant the accuracy or completeness of this specification or any information contained therein. Texas Instruments and/or its licensors do not warrant that this design will meet the specifications, will be suitable for your application or fit for any particular purpose, or will operate in an implementation. Texas Instruments and/or its licensors do not warrant that the design is production worthy. You should completely validate and test your design implementation to confirm the system functionality for your application.

Orderable: IW/R6843LCEVM	Designed for: Public Release	Mod. Date: 4/28/2021
TID #: N/A	Project Title: IW/R6843 LOW COST EVM	
Number: PROC116 Rev: A	Sheet Title: QSPI Flash	
SVN Rev: Unknown revision	Assembly Variant: 001_IWR	Sheet: 7 of 14
Drawn By: Chethan Kumar.Y.B	File: PROC116A_QSPI_Flash_section.SchDoc	Size: B
Engineer: Chethan Kumar.Y.B	Contact: http://www.ti.com/support	



© Texas Instruments 2020

CONNECTORS

60 PIN HD CONNECTOR

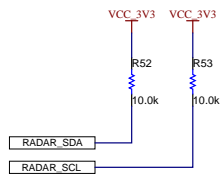
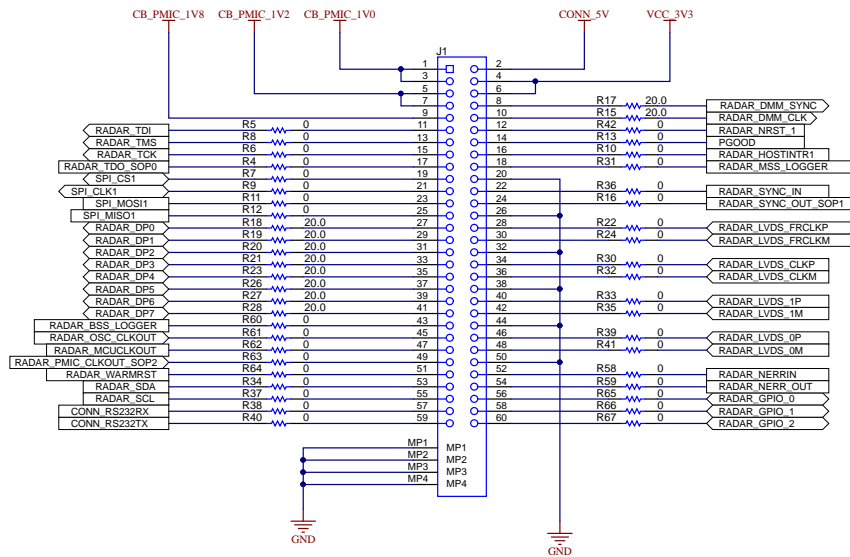

60 PIN HD CONNECTOR FOR xWRxxxx DEVICES COMPATABILITY

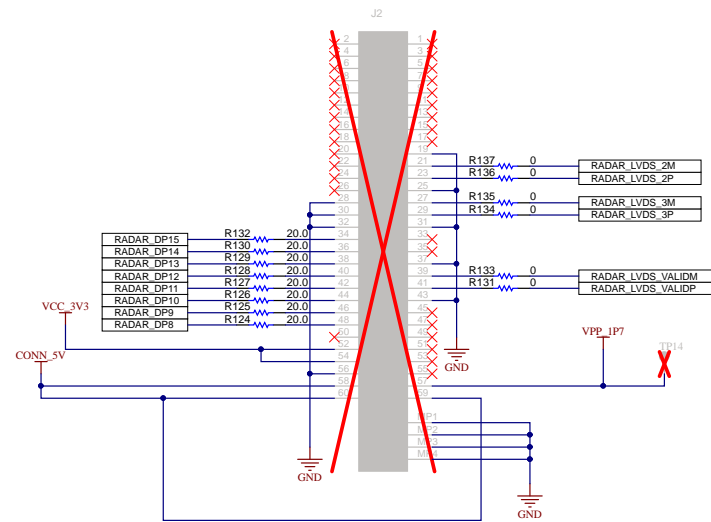

Texas Instruments and/or its licensors do not warrant the accuracy or completeness of this specification or any information contained therein. Texas Instruments and/or its licensors do not warrant that this design will meet the specifications, will be suitable for your application or fit for any particular purpose, or will operate in an implementation. Texas Instruments and/or its licensors do not warrant that the design is production worthy. You should completely validate and test your design implementation to confirm the system functionality for your application.

Orderable: IW6843LCEVM	Designed for: Public Release	Mod. Date: 4/28/2021
TID #: N/A	Project Title: IW6843 LOW COST EVM	
Number: PROC116	Rev: A	Sheet Title: HD Connector
SVN Rev: Unknown revision	Assembly Variant: 001_IWR	Sheet: 8 of 14
Drawn By: Chethan Kumar Y.B	File: PROC116A_HD_Connector_60Pin_SchDoc	Size: B
Engineer: Chethan Kumar Y.B	Contact: http://www.ti.com/support	

CURRENT SENSOR

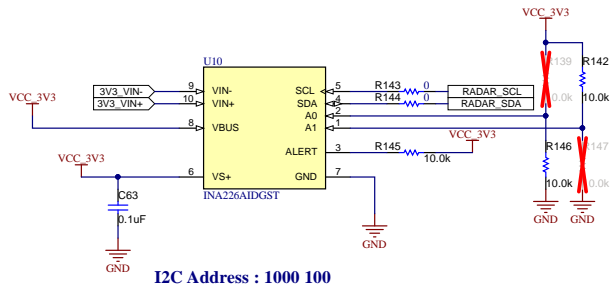
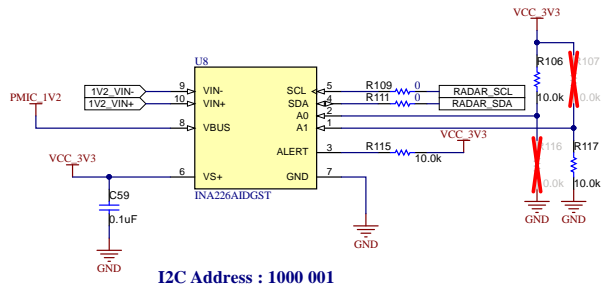
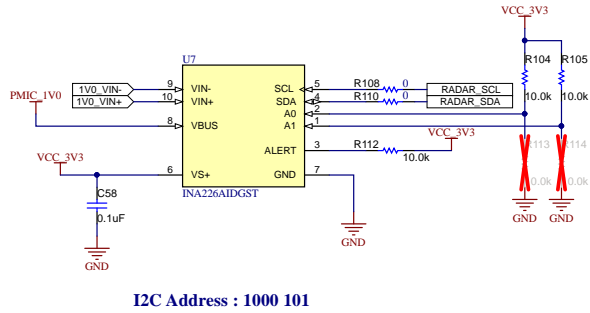
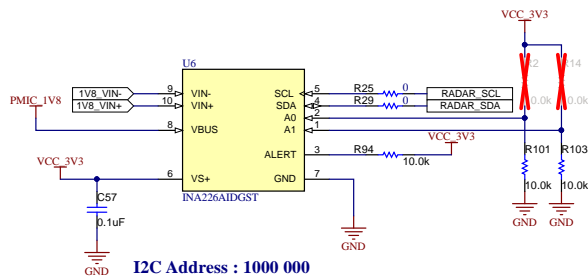

TEMPERATURE SENSOR

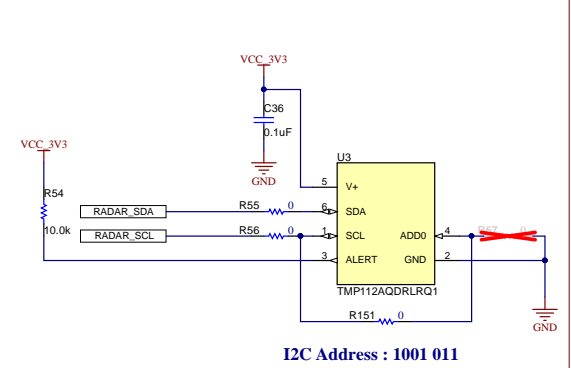

EEPROM

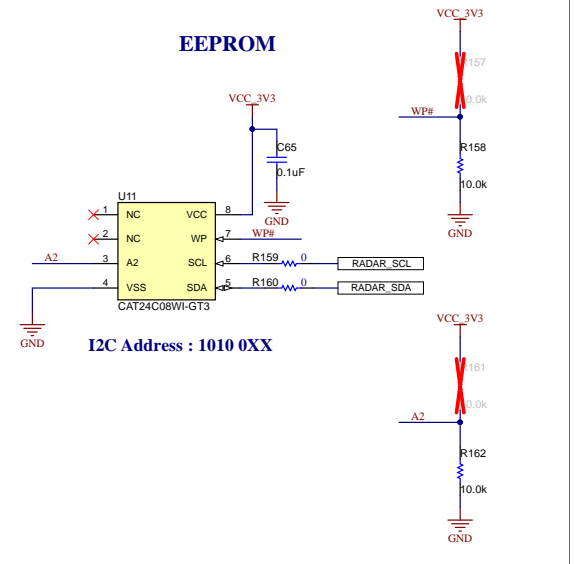

Texas Instruments and/or its licensors do not warrant the accuracy or completeness of this specification or any information contained therein. Texas Instruments and/or its licensors do not warrant that this design will meet the specifications, will be suitable for your application or fit for any particular purpose, or will operate in an implementation. Texas Instruments and/or its licensors do not warrant that the design is production worthy. You should completely validate and test your design implementation to confirm the system functionality for your application.

Orderable: IW/R6843LCEVM	Designed for: Public Release	Mod. Date: 4/28/2021
TID #: N/A	Project Title: IW/R6843 LOW COST EVM	
Number: PROC116	Rev: A	Sheet Title: Temp Current sensor
SVN Rev: Unknown revision	Assembly Variant: 001_IWR	Sheet: 9 of 14
Drawn By: Chethan Kumar.Y.B	File: PROC116A_Temp_Current_sensor_SchDoc	Size: B
Engineer: Chethan Kumar.Y.B	Contact: http://www.ti.com/support	

USB CONNECTOR

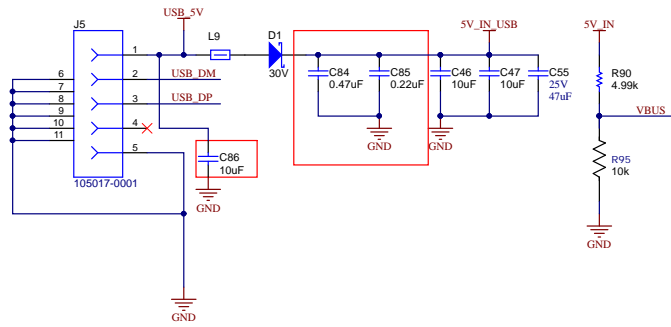

USB to UART

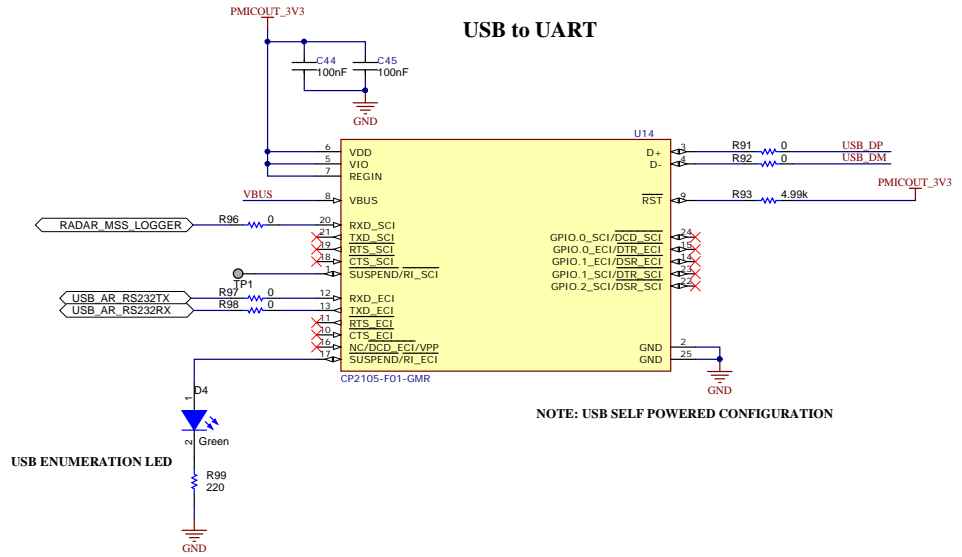

NOTE: USB SELF POWERED CONFIGURATION

UART SELECTION

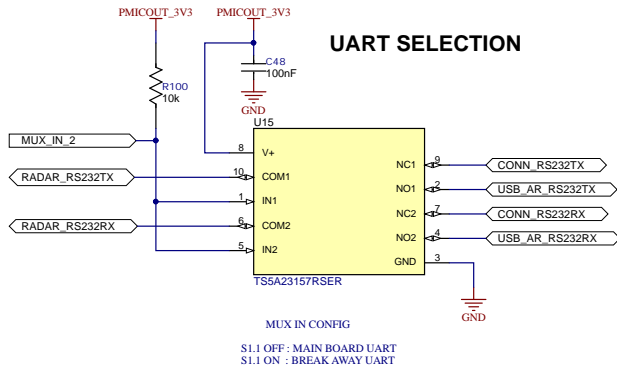

CONNECTOR PWR / USB PWR LOAD SWITCH

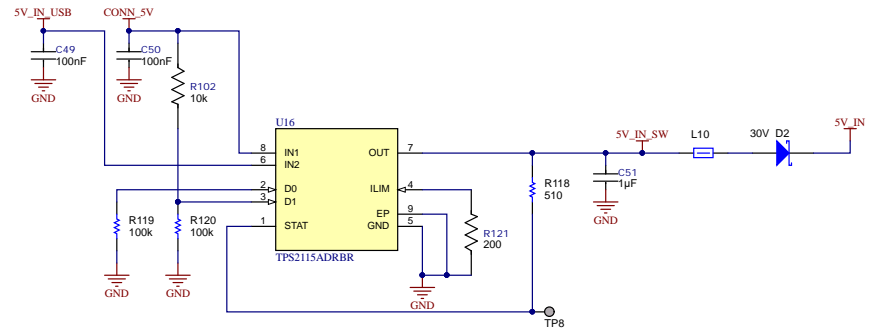

Texas Instruments and/or its licensors do not warrant the accuracy or completeness of this specification or any information contained therein. Texas Instruments and/or its licensors do not warrant that this design will meet the specifications, will be suitable for your application or fit for any particular purpose, or will operate in an implementation. Texas Instruments and/or its licensors do not warrant that the design is production worthy. You should completely validate and test your design implementation to confirm the system functionality for your application.

Orderable: IW/R6843LCEVM	Designed for: Public Release	Mod. Date: 4/28/2021
TID #: N/A	Project Title: IW/R6843 LOW COST EVM	
Number: PROC116	Rev: A	Sheet Title: Flash USB to UART
SVN Rev: Unknown revision	Assembly Variant: 001_IWR	Sheet: 10 of 14
Drawn By: Chethan Kumar Y.B	File: PROC116A_Flash_USB_To_UART.SchDoc	Size: B
Engineer: Chethan Kumar Y.B	Contact: http://www.ti.com/support	

60PIN HD CONNECTOR FOR DCA1000

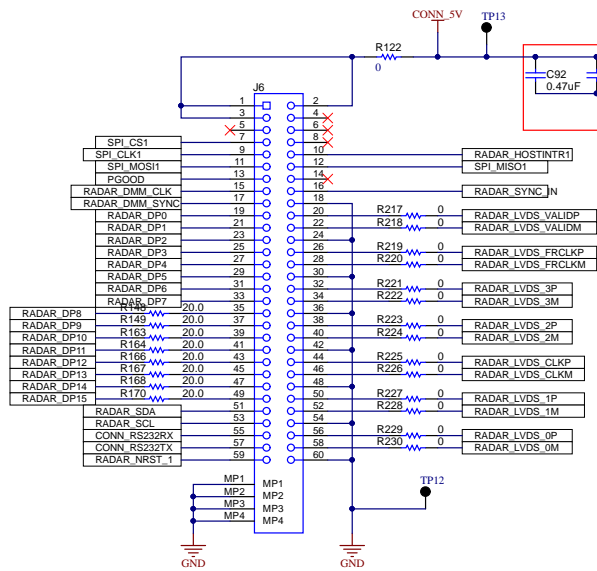

RESET, USER LED and SWITCHES

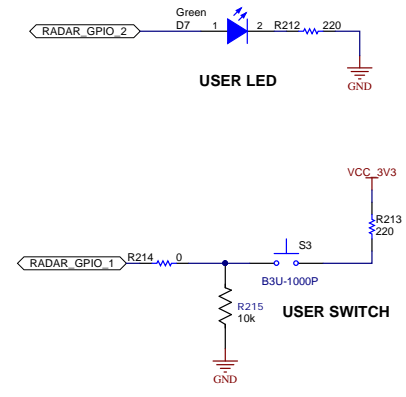
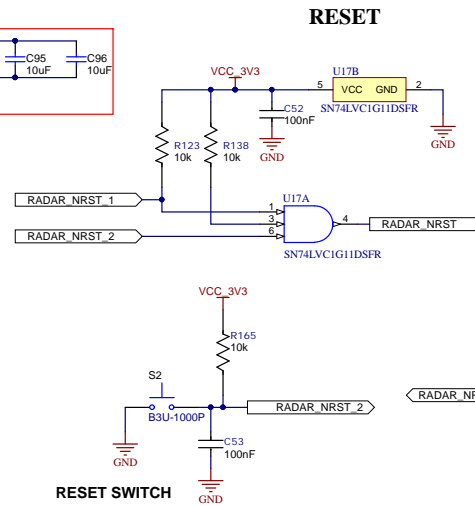

Texas Instruments and/or its licensors do not warrant the accuracy or completeness of this specification or any information contained therein. Texas Instruments and/or its licensors do not warrant that this design will meet the specifications, will be suitable for your application or fit for any particular purpose, or will operate in an implementation. Texas Instruments and/or its licensors do not warrant that the design is production worthy. You should completely validate and test your system implementation to confirm the system functionality for your application.

Orderable: IW/R6843LCEVM	Designed for: Public Release	Mod. Date: 4/28/2021
TID #: N/A	Project Title: IW/R6843 LOW COST EVM	
Number: PROC116	Rev: A	Sheet Title: HD DCA Connector
SVN Rev: Unknown revision	Assembly Variant: 001_IWR	Sheet 11 of 14
Drawn By: Chethan Kumar.Y.B	File: PROC116A_HD_DCA_Conn.SchDoc	Size: B
Engineer: Chethan Kumar.Y.B	Contact: http://www.ti.com/support	

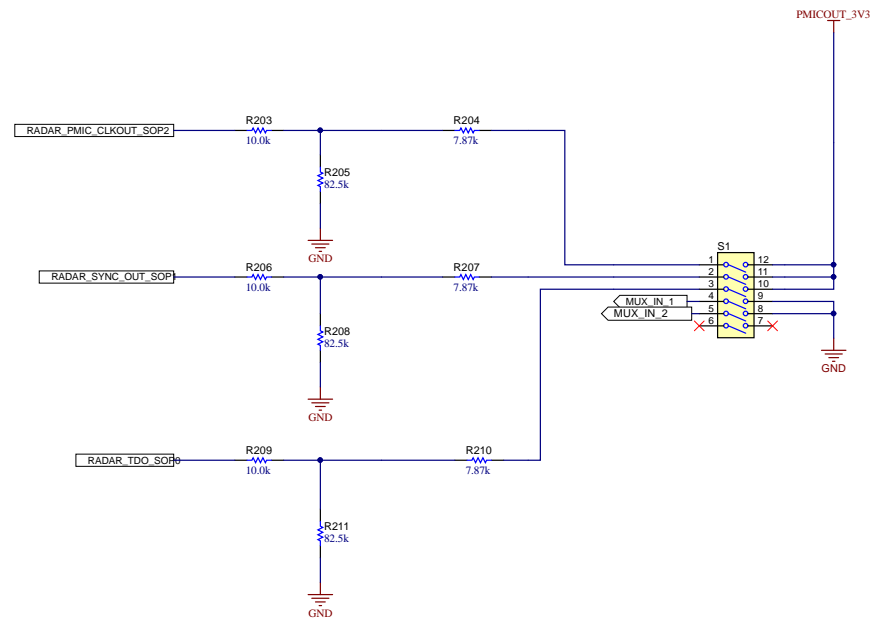

Texas Instruments and/or its licensors do not warrant the accuracy or completeness of this specification or any information contained therein. Texas Instruments and/or its licensors do not warrant that this design will meet the specifications, will be suitable for your application or fit for any particular purpose, or will operate in an implementation. Texas Instruments and/or its licensors do not warrant that the design is production worthy. You should completely validate and test your design implementation to confirm the system functionality for your application.

Orderable: IWR6843LCEVM	Designed for: Public Release	Mod. Date: 4/28/2021
TID #: N/A	Project Title: IWR6843 LOW COST EVM	
Number: PROC116	Rev: A	Sheet Title: SOP Control
SVN Rev: Unknown revision	Assembly Variant: 001_IWR	Sheet: 12 of 14
Drawn By: Chethan Kumar.Y.B	File: PROC116A_SOP_Ctrl_SchDoc	Size: B
Engineer: Chethan Kumar.Y.B	Contact: http://www.ti.com/support	



CAN_FD TRANSCEIVER

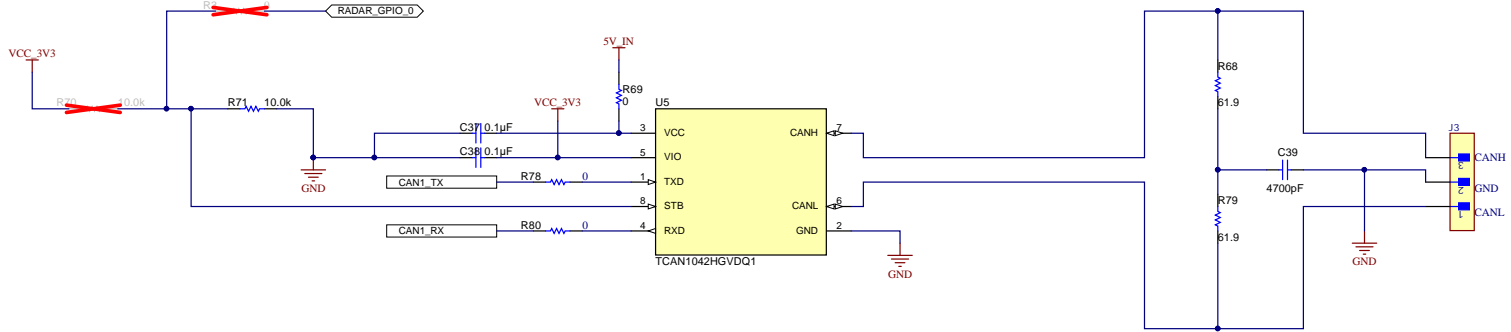

CAN_FD TRANSCEIVER

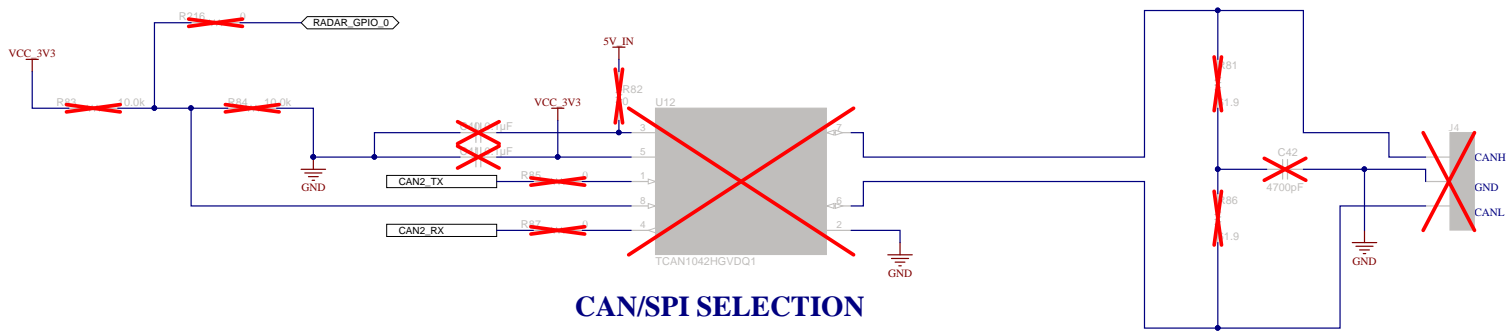

CAN/SPI SELECTION

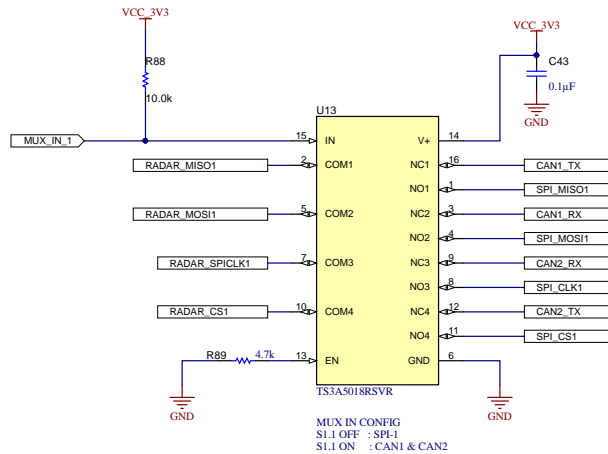

Texas Instruments and/or its licensors do not warrant the accuracy or completeness of this specification or any information contained therein. Texas Instruments and/or its licensors do not warrant that this design will meet the specifications, will be suitable for your application or fit for any particular purpose, or will operate in an implementation. Texas Instruments and/or its licensors do not warrant that the design is production worthy. You should completely validate and test your implementation to confirm the system functionality for your application.

Orderable: IW/R6843LCEVM	Designed for: Public Release	Mod. Date: 4/28/2021
TID #: N/A	Project Title: IW/R6843 LOW COST EVM	
Number: PROC116	Rev: A	Sheet Title: CAN Interface
SVN Rev: Unknown revision	Assembly Variant: 001_IWR	Sheet: 13 of 14
Drawn By: Chethan Kumar.Y.B	File: PROC116A_Can_Interface_SchDoc	Size: B
Engineer: Chethan Kumar.Y.B	Contact: http://www.ti.com/support	

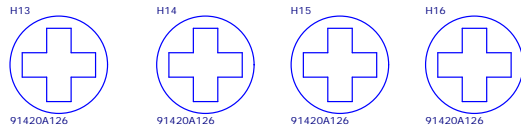
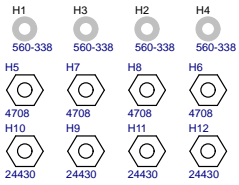

PCB Number: PROC116
PCB Rev: A

PCB LOGO
Texas Instruments



PCB LOGO
FCC disclaimer

PCB LOGO
WEEE logo

PCB LOGO
Texas Instruments

CAUTION HOT SURFACE1



CAUTION HOT SURFACE

Variant/Label Table	
Variant	Label Text
001_IWR	IWR6843ISK_LOW_EVM
002_AWR	AWR6843ISK_LOW_EVM

LBL1

PCB Label

TH:14-423-10
Size: 0.65" x 0.20"

ZZ1

Label Assembly Note

This Assembly Note is for PCB labels only

ZZ2

Assembly Note

These assemblies are ESD sensitive, ESD precautions shall be observed.

ZZ3

Assembly Note

These assemblies must be clean and free from flux and all contaminants. Use of no clean flux is not acceptable.

ZZ4

Assembly Note

These assemblies must comply with workmanship standards IPC-A-610 Class 2, unless otherwise specified.

ZZ5

Assembly Note

INDICATION FOR COMPONENTS D* ARE GIVEN AT THEIR CATHODE SIDE.

CAPACITORS HIGHLIGHTED IN THE RED COLOR BOXES ARE ADDED FOR IMPROVEMENT AND THOSE ARE NOT MANDATORY.

Texas Instruments and/or its licensors do not warrant the accuracy or completeness of this specification or any information contained therein. Texas Instruments and/or its licensors do not warrant that this design will meet the specifications, will be suitable for your application or fit for any particular purpose, or will operate in an implementation. Texas Instruments and/or its licensors do not warrant that the design is production worthy. You should completely validate and test your design implementation to confirm the system functionality for your application.

Orderable: IWR6843LCEVM	Designed for: Public Release	Mod. Date: 4/28/2021
TID #: N/A	Project Title: IWR6843 LOW COST EVM	
Number: PROC116	Rev: A	Sheet Title: Hardware
SVN Rev: Unknown revision	Assembly Variant: 001_IWR	Sheet: 14 of 14
Drawn By: Chethan Kumar.Y.B	File: PROC116A_EVM_Hardware_SchDoc	Size: B
Engineer: Chethan Kumar.Y.B	Contact: http://www.ti.com/support	



© Texas Instruments 2020