

PSRR

TIPL 1232

TI Precision Labs – Op Amps

Presented by Collin Wells

Prepared by Collin Wells, Art Kay, Ian Williams, and Tim Green

Prerequisites: Input and Output Limitations 1 – 3

(TIPL1130 – TIPL1132)

Referring Error to Input (RTI)

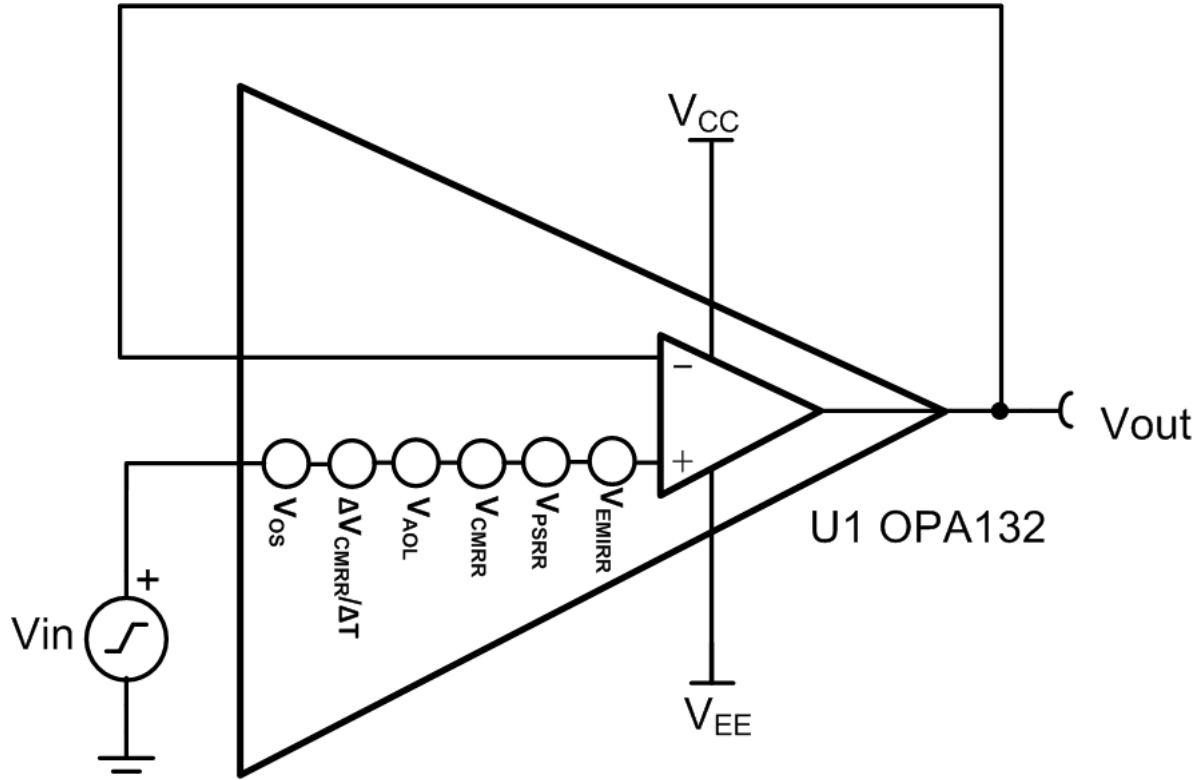

DC PSRR

At $T_A = +25^\circ\text{C}$, $V_S = \pm 15\text{V}$, unless otherwise noted.

PARAMETER	CONDITION	OPA132P, U OPA2132P, U			UNITS
		MIN	TYP	MAX	
OFFSET VOLTAGE					
Input Offset Voltage vs Temperature ⁽¹⁾	Operating Temperature Range $V_S = \pm 2.5\text{V to } \pm 18\text{V}$ $R_L = 2\text{k}\Omega$		± 0.25	± 0.5	mV
vs Power Supply			± 2	± 10	$\mu\text{V}/^\circ\text{C}$
Channel Separation (dual and quad)			5	15	$\mu\text{V}/\text{V}$
			0.2		$\mu\text{V}/\text{V}$

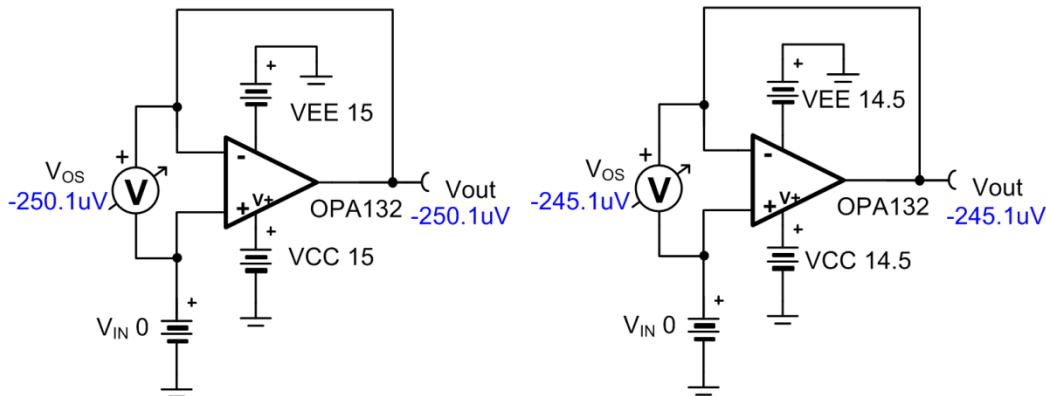

Power Supply Rejection Example

$$\Delta V_{os} = 250.1\mu\text{V} - 245.1\mu\text{V} = 5\mu\text{V}$$

$$\Delta V_{Supply} = 30\text{V} - 29\text{V} = 1\text{V}$$

$$PSRR(\mu\text{V}/\text{V}) = \frac{\Delta V_{os}}{\Delta V_{Supply}} = \frac{5\mu\text{V}}{1\text{V}} = 5\mu\text{V}/\text{V}$$

$$PSRR(\text{dB}) = -20 \log\left(\frac{5\mu\text{V}}{1\text{V}}\right) = 106\text{dB}$$

Power Supply Rejection Definitions

$$\Delta V_{os} = V_{os1} - V_{os2}$$

V_{os} measured at two different supply voltages

$$\Delta V_{Supply} = V_{s1} - V_{s2}$$

The difference in the supply voltages

$$PSRR(\text{V}/\text{V}) = \frac{\Delta V_{os}}{\Delta V_{Supply}}$$

Power supply rejection ratio in $\mu\text{V}/\text{V}$

$$PSRR(\text{dB}) = -20 \log\left(\frac{\Delta V_{os}}{\Delta V_{Supply}}\right)$$

Power supply rejection ratio in dB

PSRR & CMRR Combined Effects: Supply Symmetry

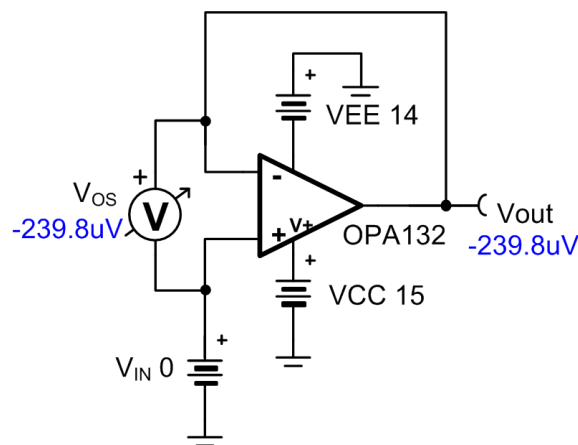
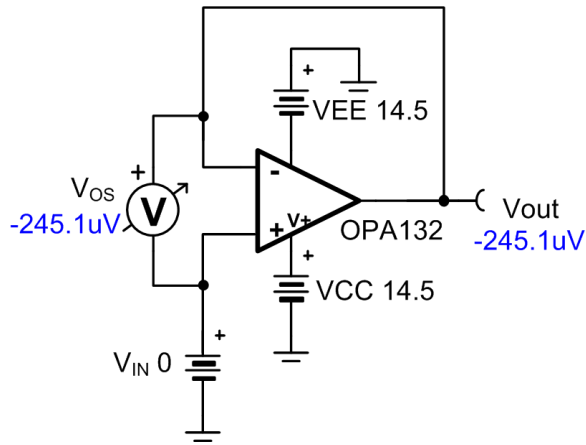
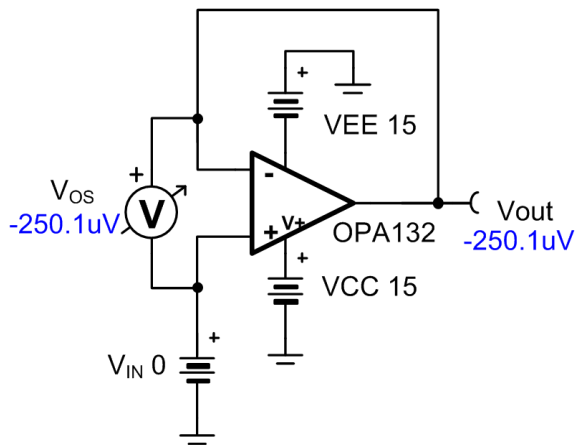

$$\frac{V_{CC} + V_{EE}}{2} = \frac{15V + (-15V)}{2} = 0V$$

$$V_{CM} = 0V$$

$$V_{OS} \text{ is defined at } V_{CM} = \frac{V_{CC} + V_{EE}}{2}$$

If supplies shift such that $V_{CM} \neq \frac{V_{CC} + V_{EE}}{2}$
 than this is an effective shift in V_{CM}

$$\frac{V_{CC} + V_{EE}}{2} = \frac{14.5V + (-14.5V)}{2} = 0V$$

$$V_{CM} = 0V$$

Thus $\Delta V_{CM} = 0V$

The shift in V_{OS} is from PSRR

$$\frac{V_{CC} + V_{EE}}{2} = \frac{15V + (-14V)}{2} = 0.5V$$

$$V_{CM} = 0V$$

Thus $\Delta V_{CM} = 0.5V$ relative to supplies

The shift in V_{OS} is from CMRR & PSRR

Translating $\mu\text{V}/\text{V}$ to dB and Vice Versa

Useful Formulas for PSRR

$$\log\left(\frac{y}{x}\right) = -\log\left(\frac{x}{y}\right)$$

(1) Law of Logarithms

$$\text{PSRR}(\text{dB}) = -20 \log\left(\frac{\Delta V_{\text{os}}}{\Delta V_{\text{Supply}}}\right) = 20 \log\left(\frac{\Delta V_{\text{Supply}}}{\Delta V_{\text{os}}}\right)$$

(2) Using (1) to show alternative definition

$$\text{PSRR}(\text{V}/\text{V}) = \frac{\Delta V_{\text{os}}}{\Delta V_{\text{Supply}}}$$

(3) PSRR definition in V/V

$$\text{PSRR}(\text{dB}) = -20 \log(\text{PSRR}(\text{V}/\text{V}))$$

(4) Substitute (3) into (2)

$$\text{PSRR}(\text{V}/\text{V}) = 10^{\left(\frac{-\text{PSRR}(\text{dB})}{20}\right)}$$

(5) Translating dB to V/V

$$\text{PSRR}(\mu\text{V}/\text{V}) = 10^6 \cdot \text{PSRR}(\text{V}/\text{V})$$

(6) Translating V/V into $\mu\text{V}/\text{V}$

AC PSRR

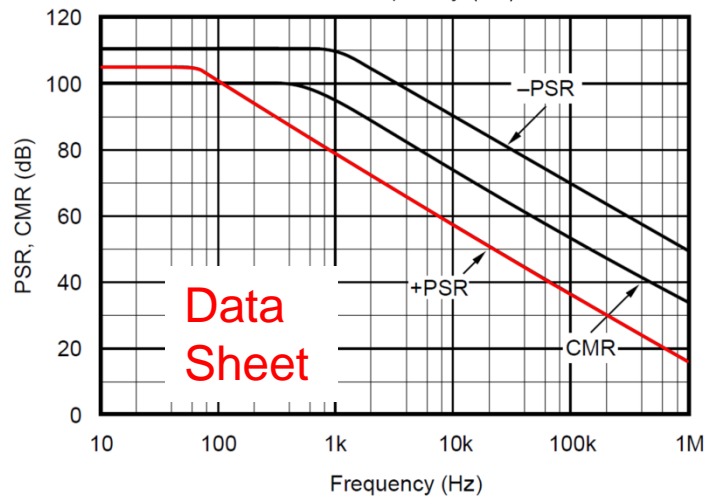
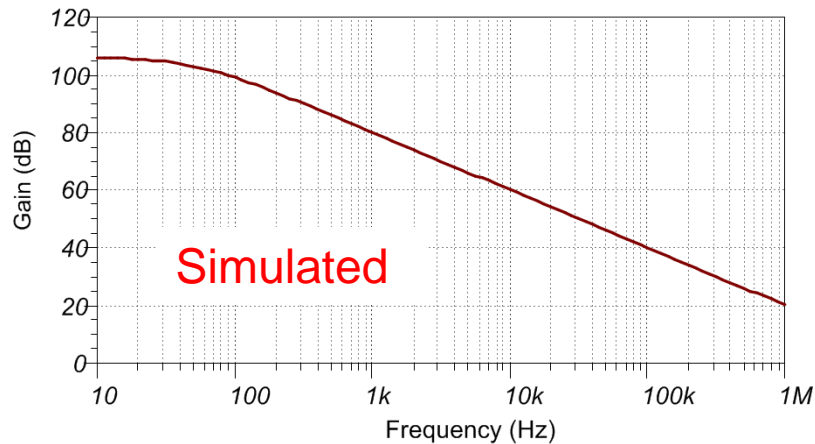
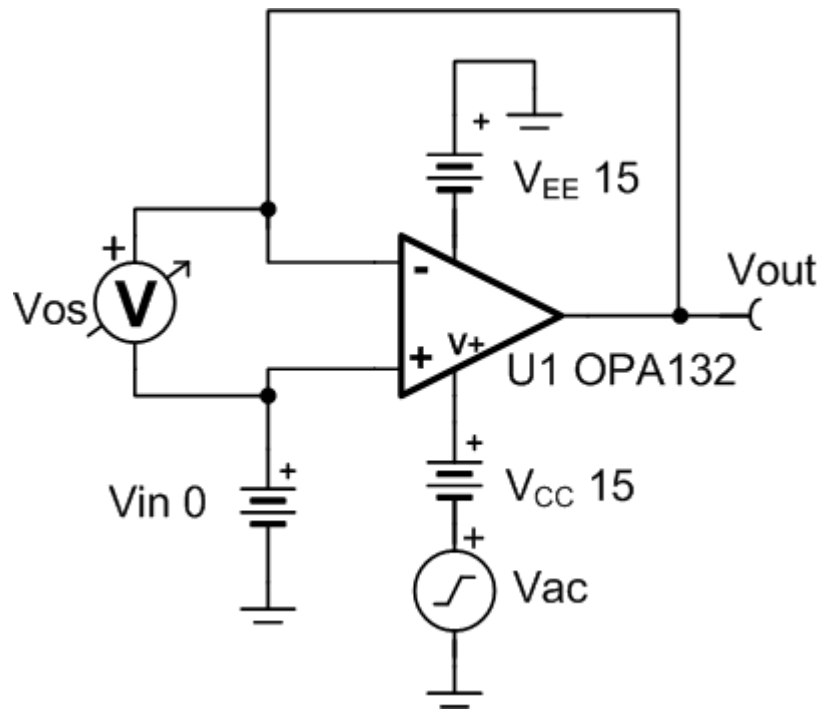

Tina: Use Post Processor

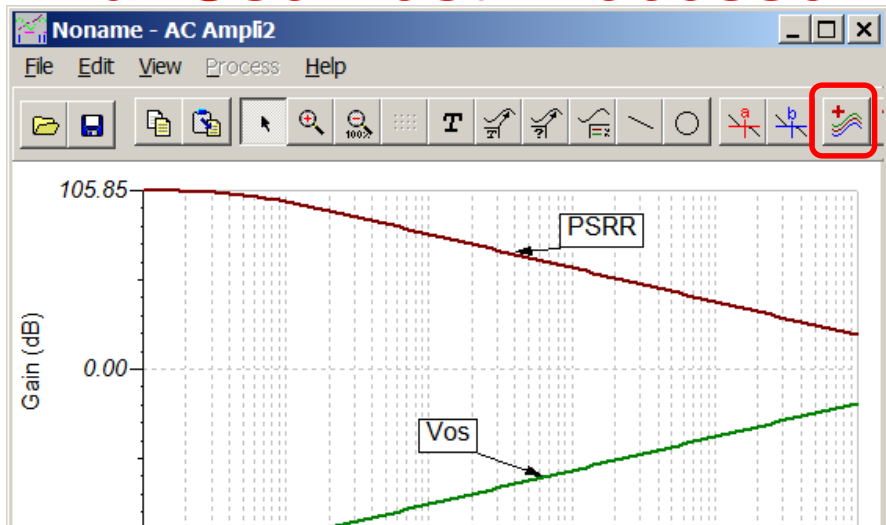

$$\text{PSRR(V/V)} = \frac{\Delta V_{\text{OS}}}{\Delta V_{\text{supply}}}$$

$$\text{PSRR(dB)} = 20 \cdot \log\left(\frac{\Delta V_{\text{supply}}}{\Delta V_{\text{OS}}}\right)$$

But $\Delta V_{\text{supply}} = 1$ and Tina automatically displays in dB, so $1/V_{\text{OS}}$ displays PSRR in dB for Tina Spice

Post-processor

Available curves:

- Vos
- Vout

Curves to insert:

OK

Cancel

Help

Show:

- Outputs
- Nodal Voltages
- Other Voltages
- Currents
- User defined
- Measurement

User defined curves

Built-in functions: +

Line Edit

1/Vos (s)

Advanced Edit

New function name: PSRR

Create

Preview

```
{This is a template}
{Don't modify the functionname}
Function F(s);
Begin
  {Your expressions here}
  {The result value}
```

ac psr opa132.TSC >> AC Transfer Analysis

AC PSRR Example

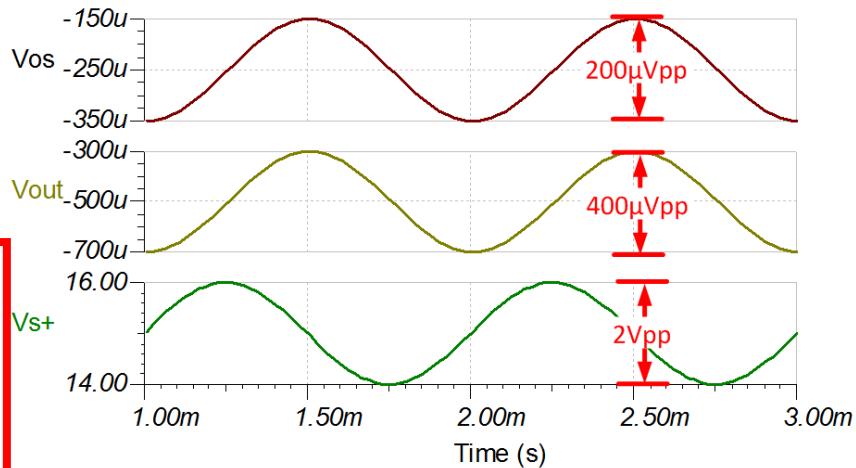
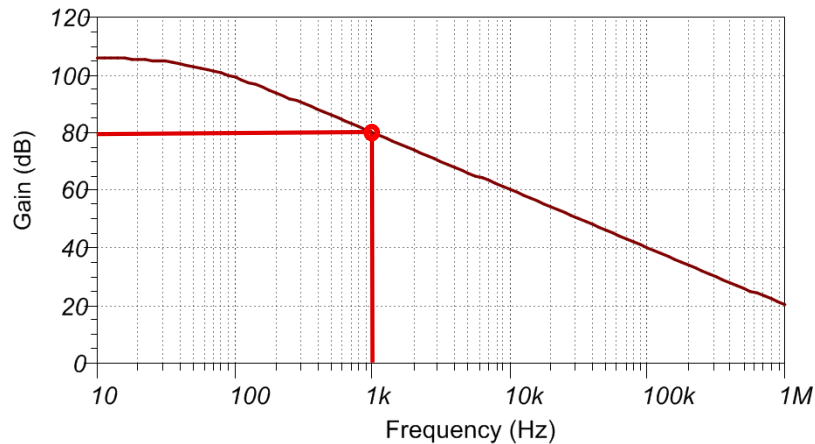
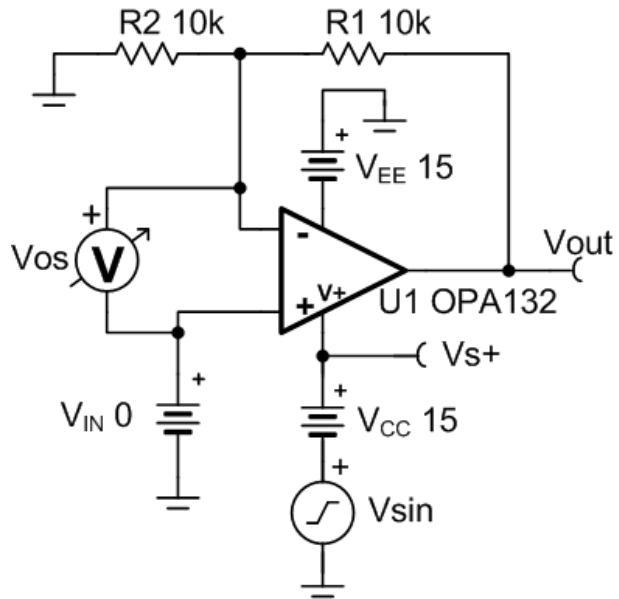

$$\text{PSRR(V/V)} = 10^{\left(\frac{-80\text{dB}}{20}\right)} = 100\mu\text{V/V}$$

$$V_{os} = V_{ac} \cdot \text{PSRR(V/V)} = 200\mu\text{V}$$

$$V_{out} = V_{os} \cdot G = (200\mu\text{V}) \cdot (2 \text{ V/V}) = 400\mu\text{V}$$

PSRR Acts Like a High Pass Filter

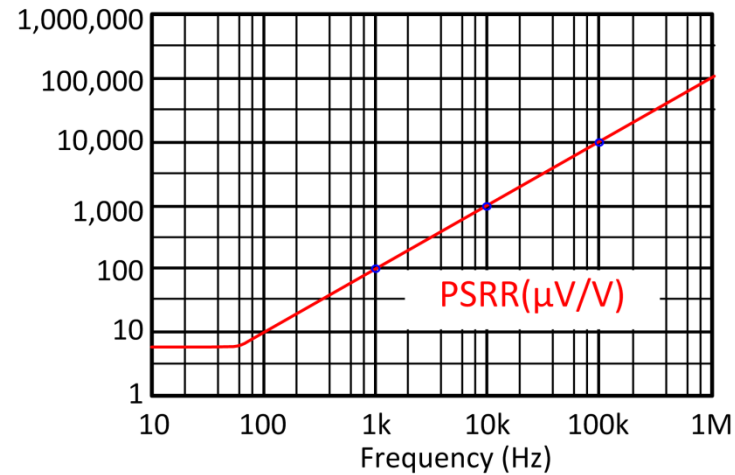
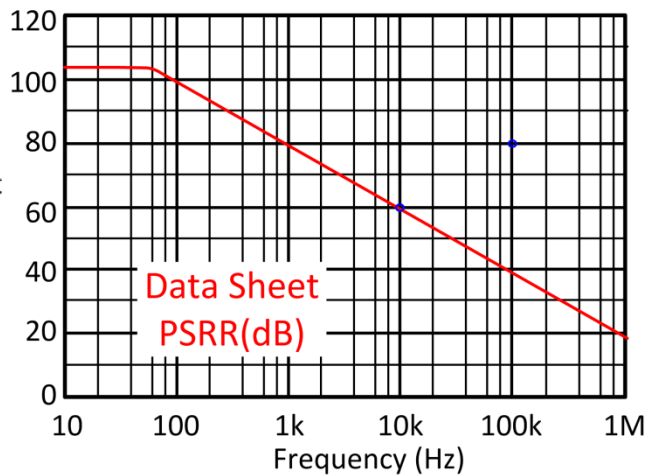
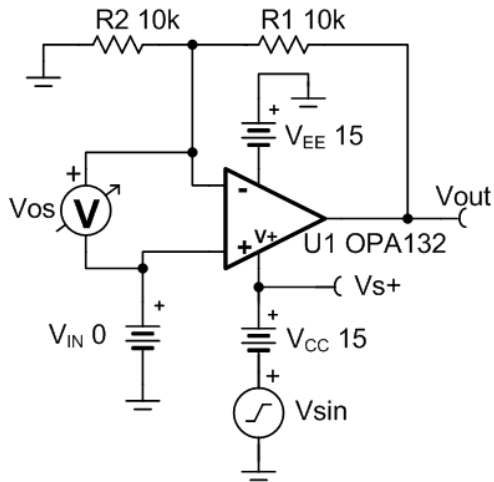

Vac	PSRR(dB)	PSRR(μV/V)	Vos	Vout
1Vpk, 1kHz	80	100	100μVpk	200μVpk
1Vpk, 10kHz	60	1,000	1mVpk	2mVpk
1Vpk, 100kHz	40	10,000	10mVpk	20mVpk

AC PSRR – Time Domain

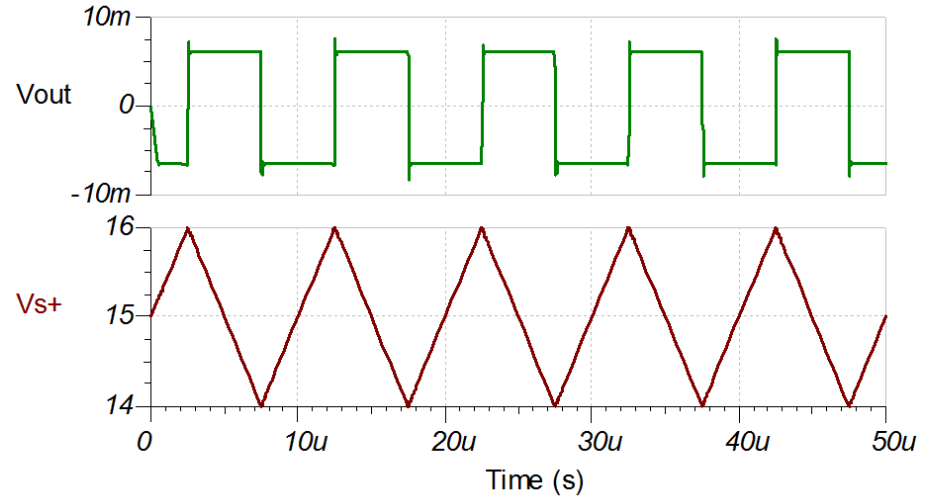
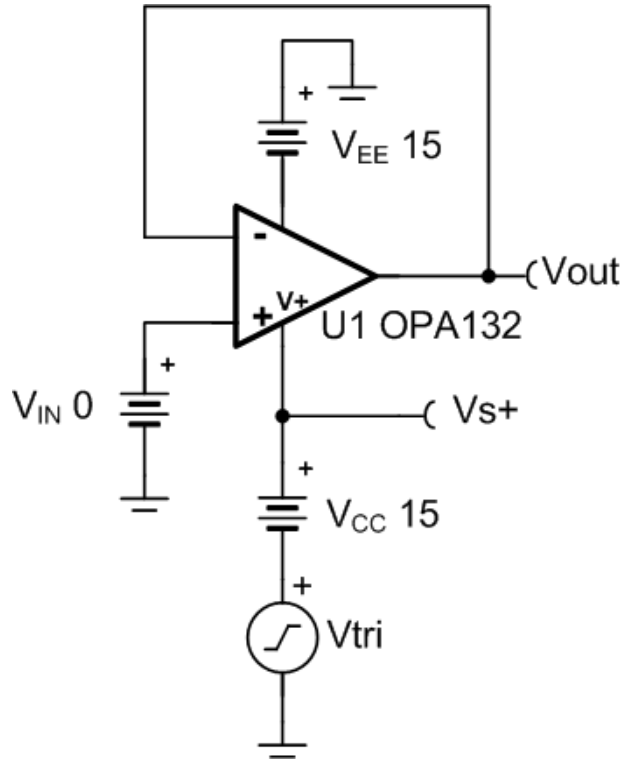

Infinite Series for a Triangle Wave

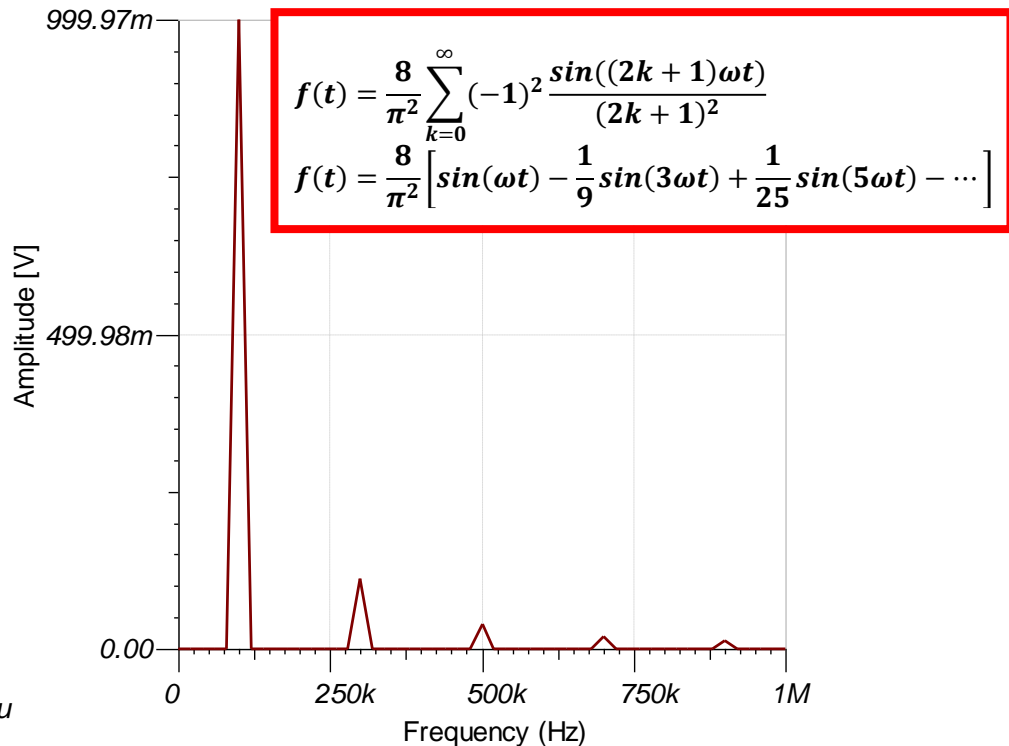
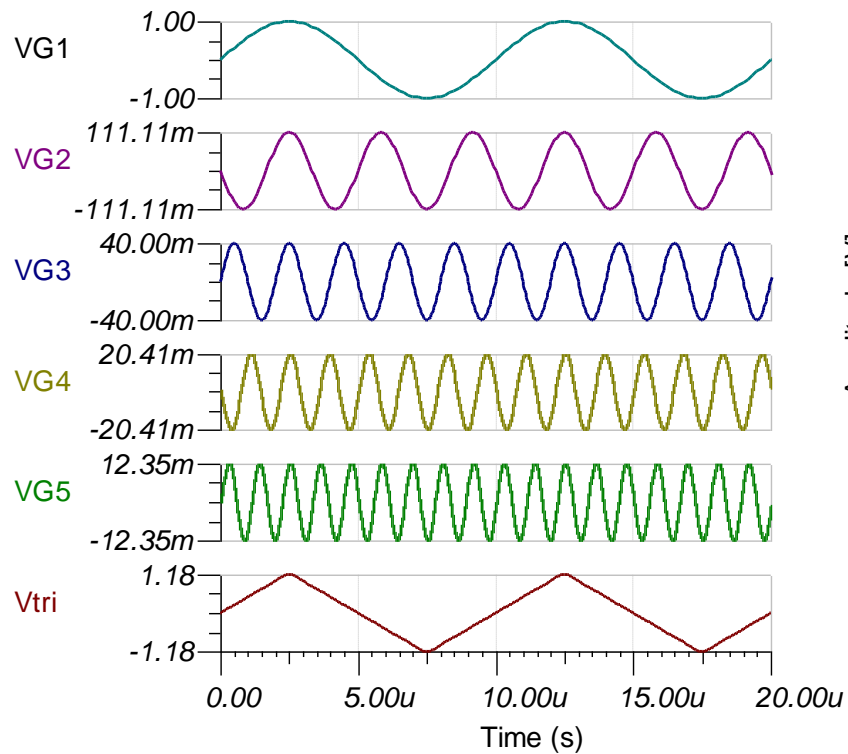

Input Spectrum vs. Output Spectrum

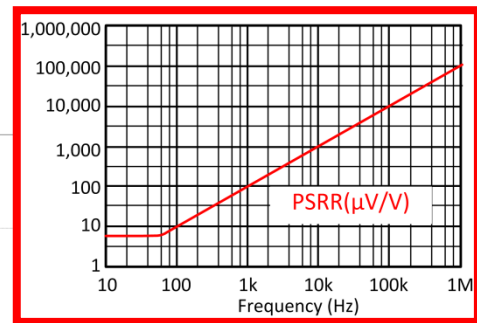
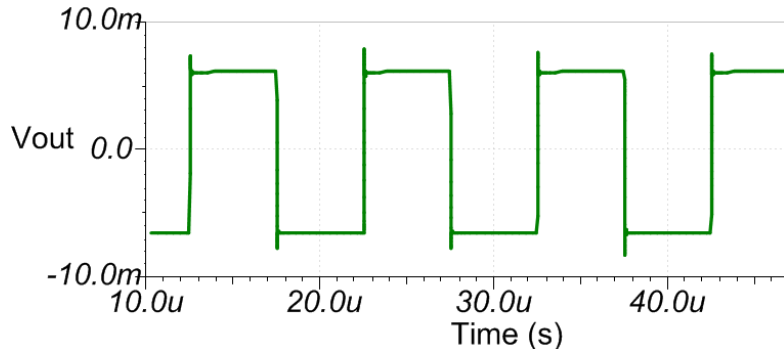
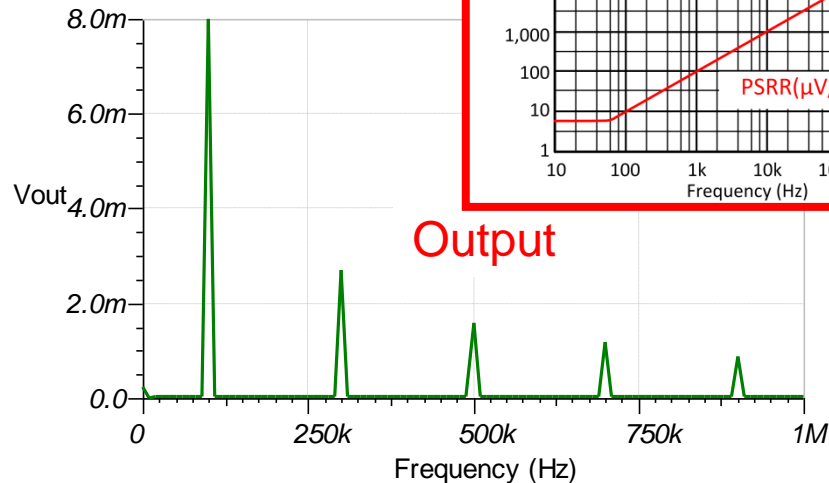
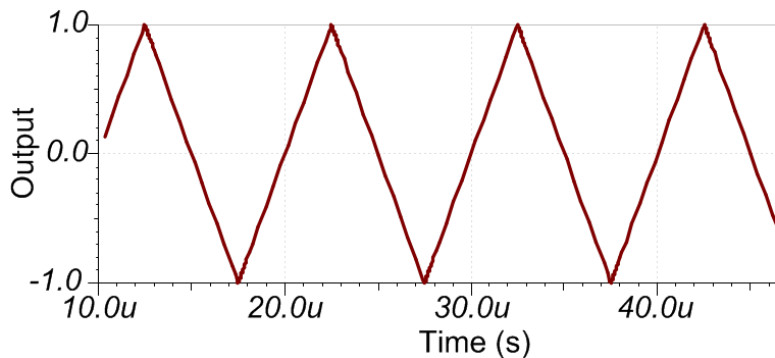
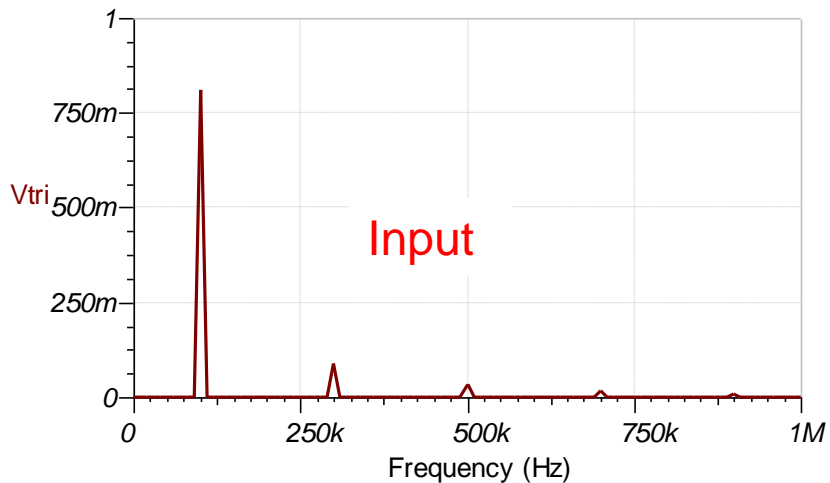

How to Generate the Fourier Spectrum in Tina

The screenshot displays the Tina SPICE Schematic Editor interface. The 'Analysis' menu is open, and the 'Fourier Spectrum...' option is selected. The 'Frequency Spectrum' dialog box is open, showing the following settings:

- Sampling start time: 0
- Sampling end time: 100u
- Minimum frequency: 0
- Maximum frequency: 1M
- Number of samples: 4096
- Window function: Uniform
- Phase correction
- Mode: Spectral density, Spectrum
- Diagrams: Complex Amplitude, Real part, Energy spectrum, Phase, Imaginary part, Amplitude
- Transient initial condition: Calculate operating point, Zero initial values, Use initial conditions

Buttons at the bottom of the dialog include OK, Cancel, and Help.

**Thanks for your time!
Please try the quiz.**