

**RJ45\_FRONT\_CONNECTOR**

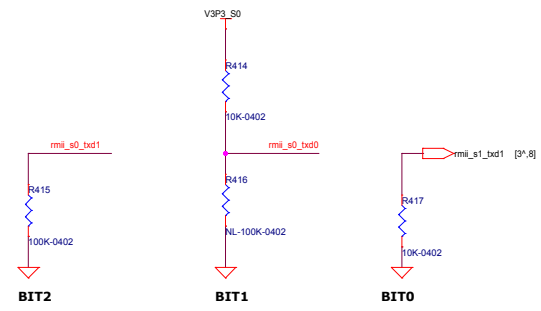

000 - QUARK SKU SETTINGS for Ethernet Phy

10/100 Mbps Ethernet PHY interface

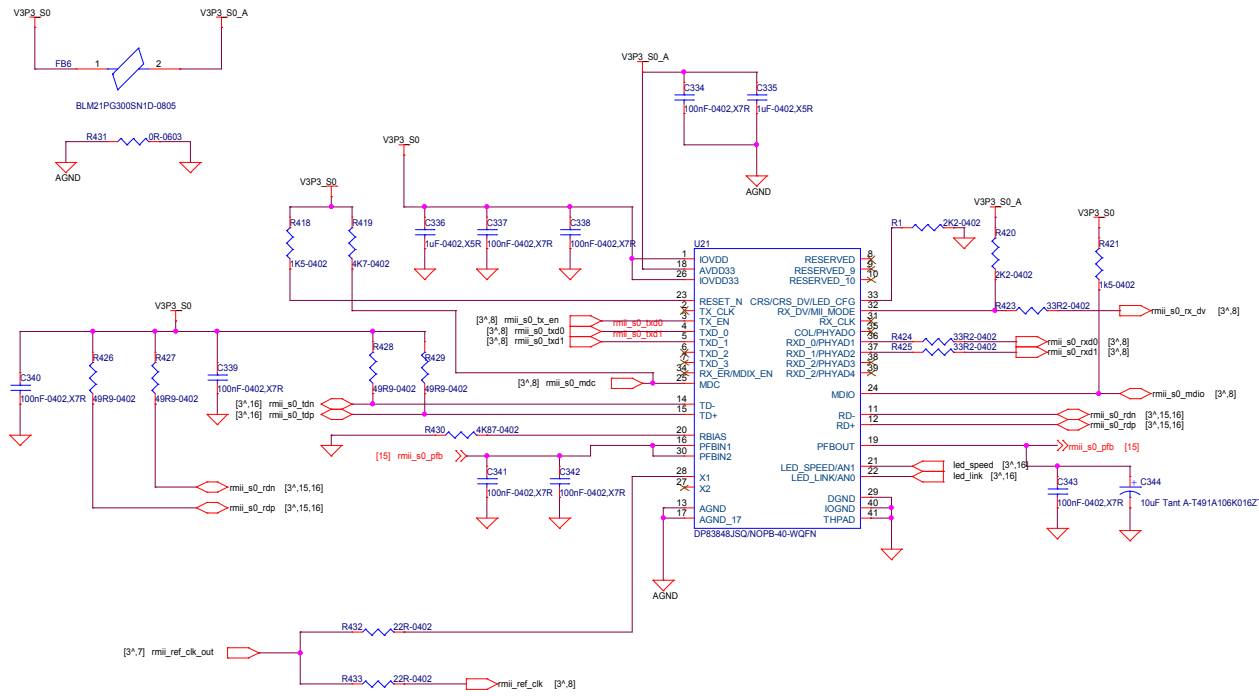
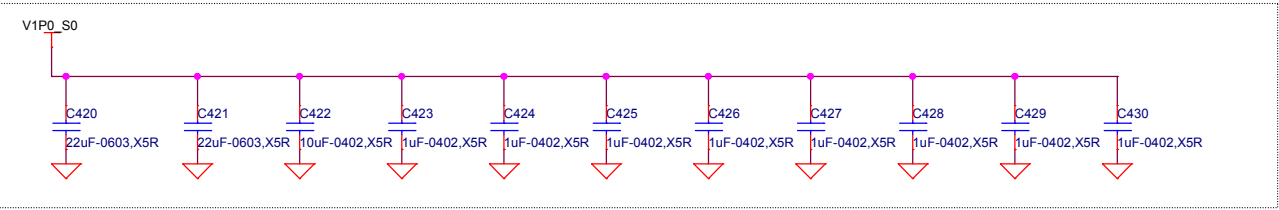
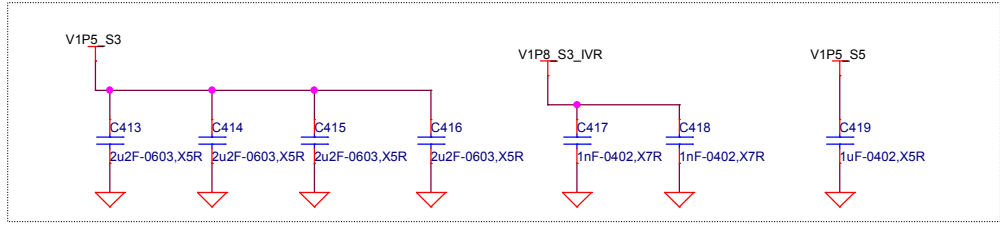
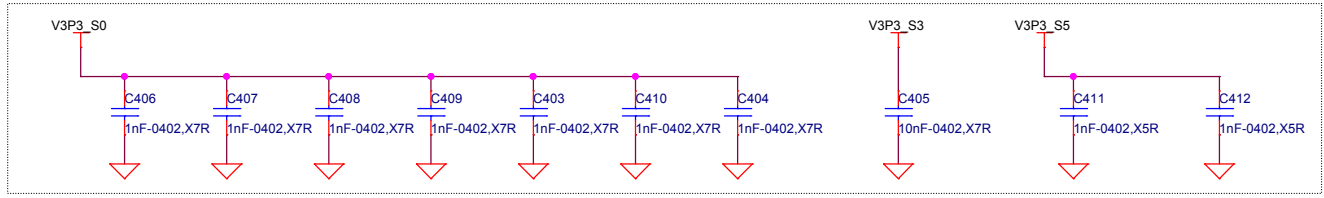

**Quarqx1000 GND Section**

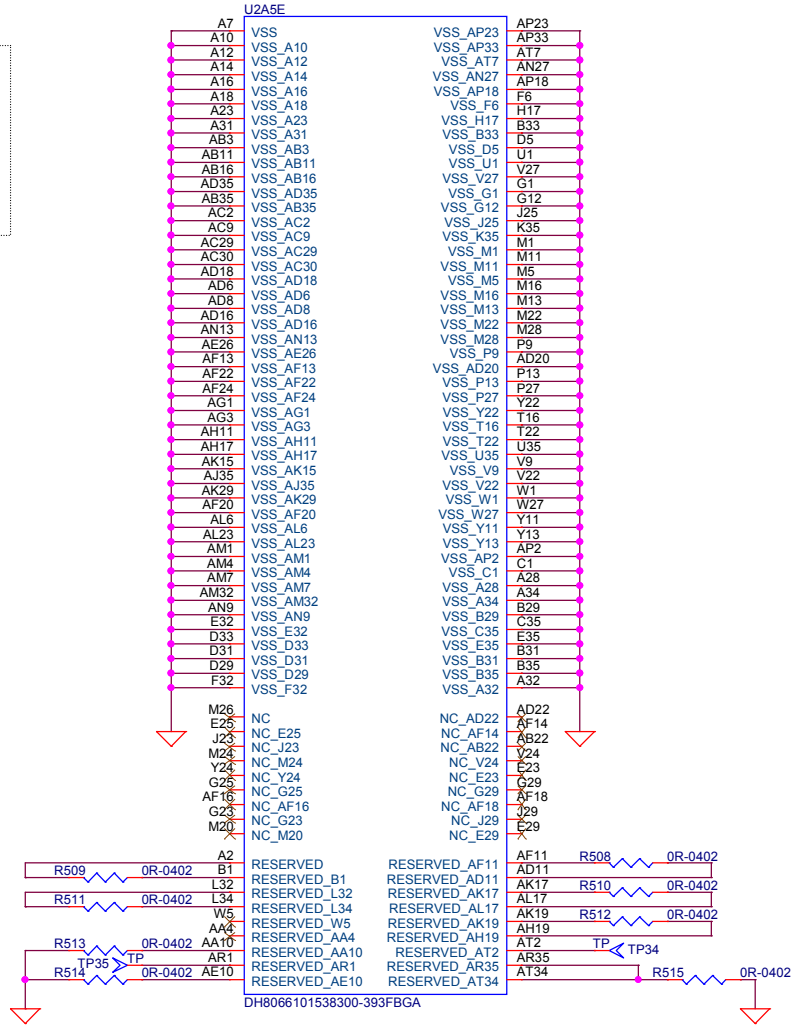



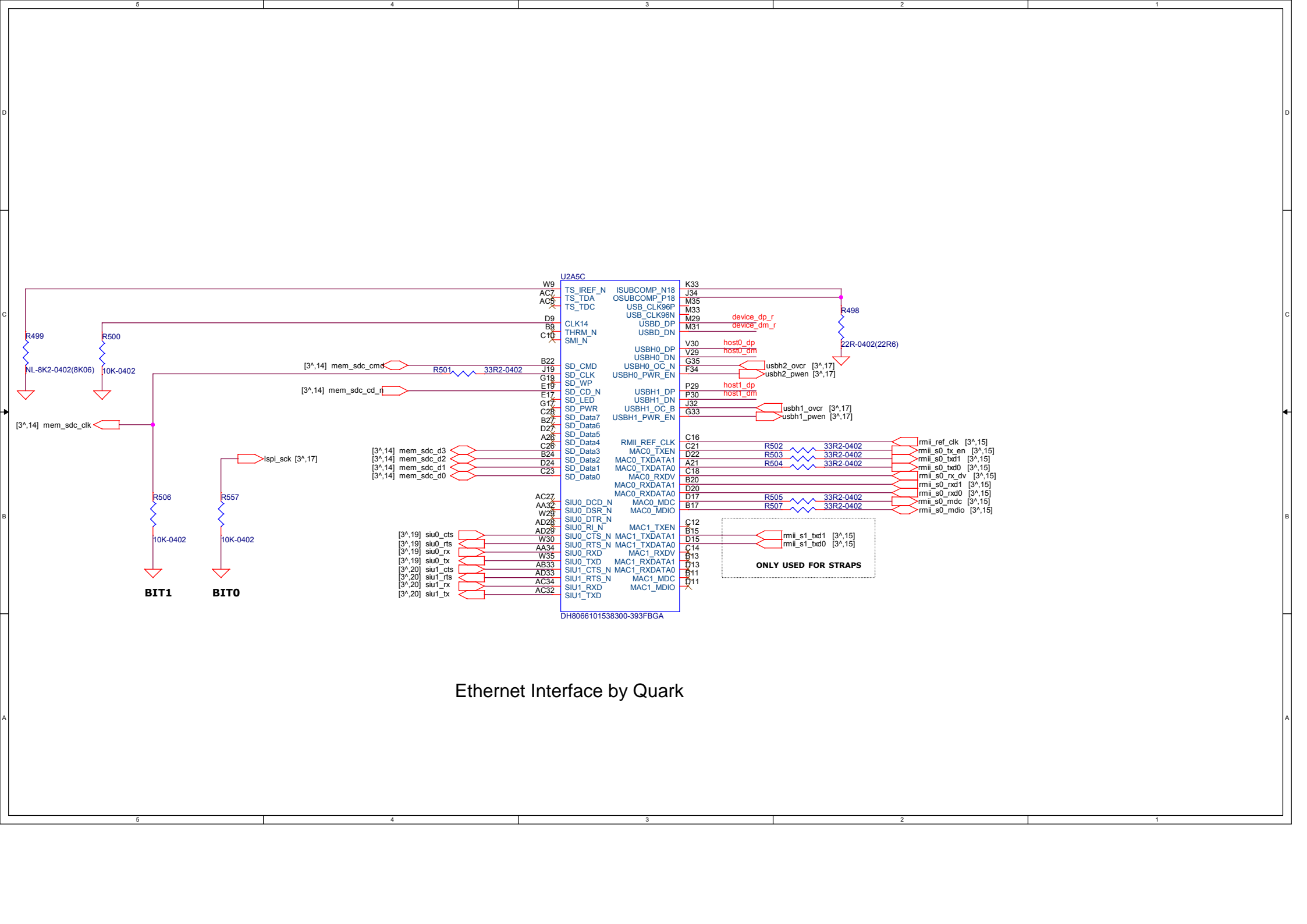

Ethernet Interface by Quark

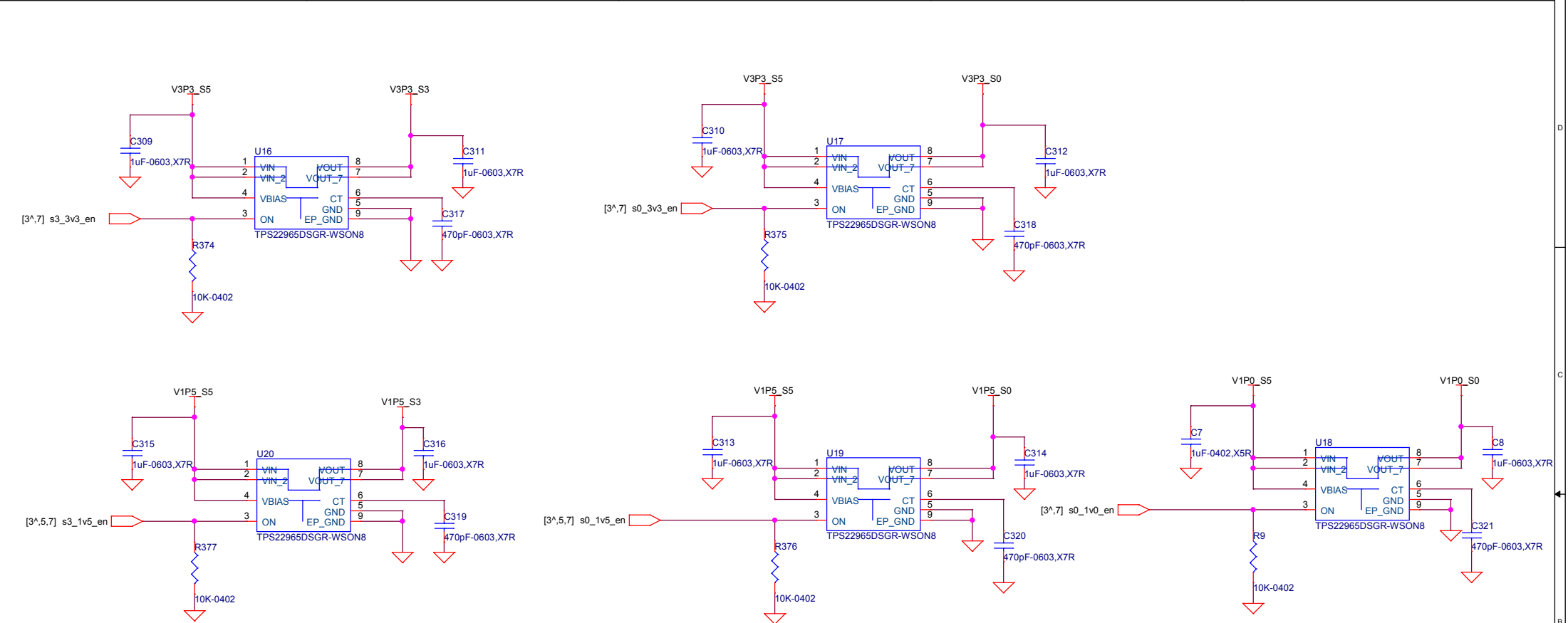

### Switching for internal supply

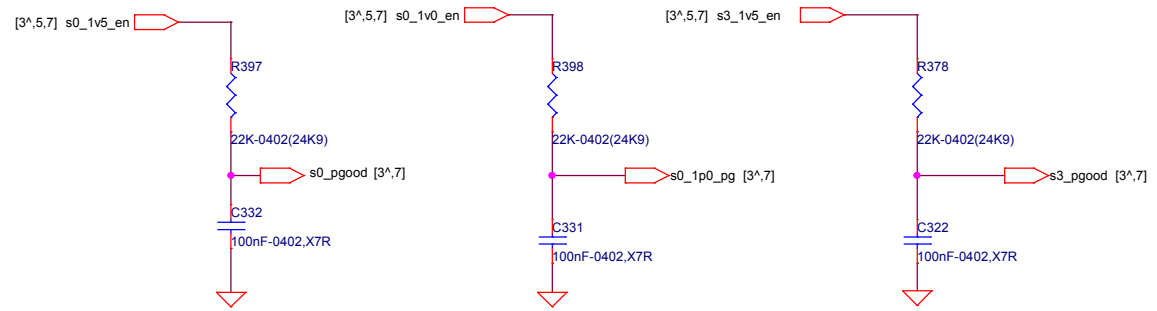

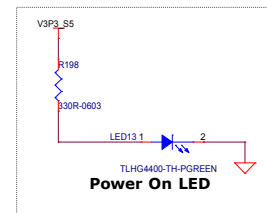
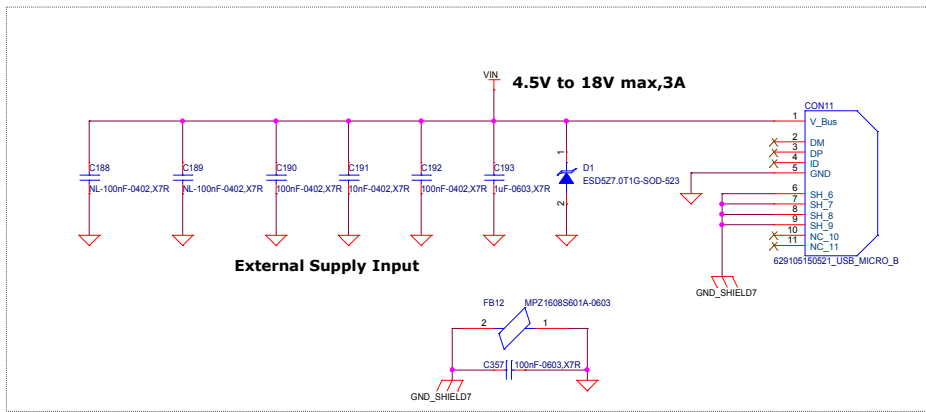

**1.0V  
MAX LOAD: 2.1A**

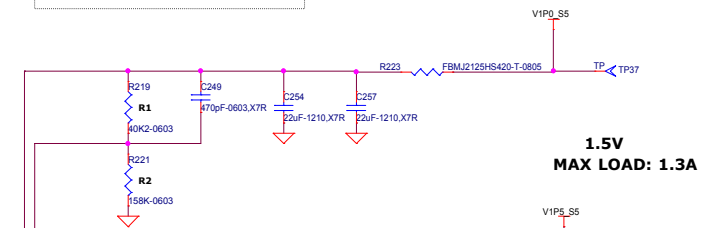

**1.5V  
MAX LOAD: 1.3A**

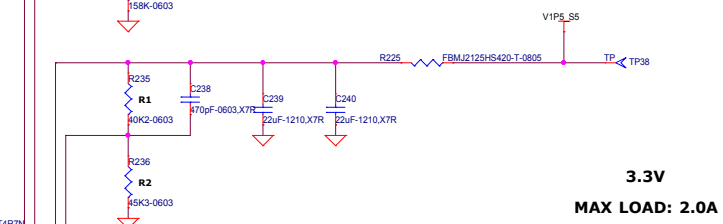

**3.3V  
MAX LOAD: 2.0A**

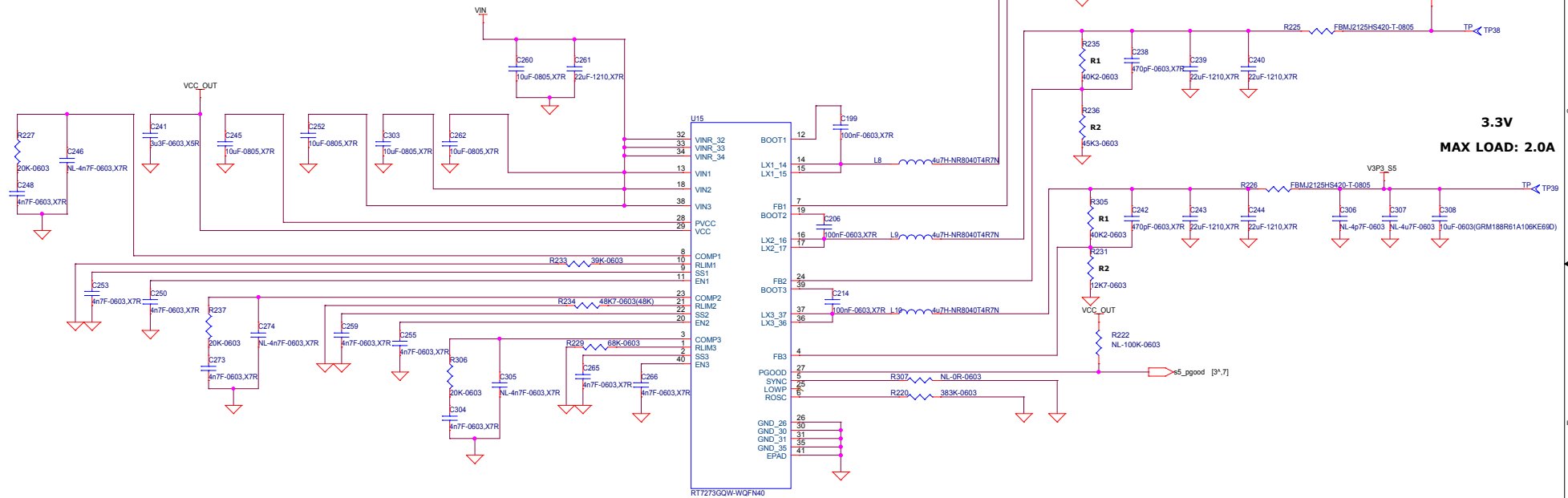
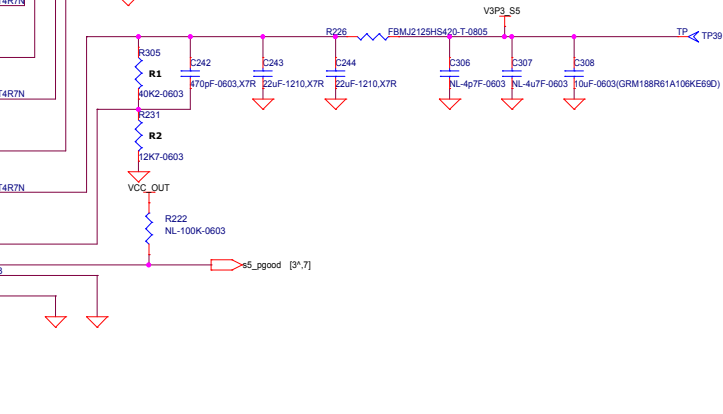

**Step Down Three Buck switcher PMIC**