

D

D

C

C

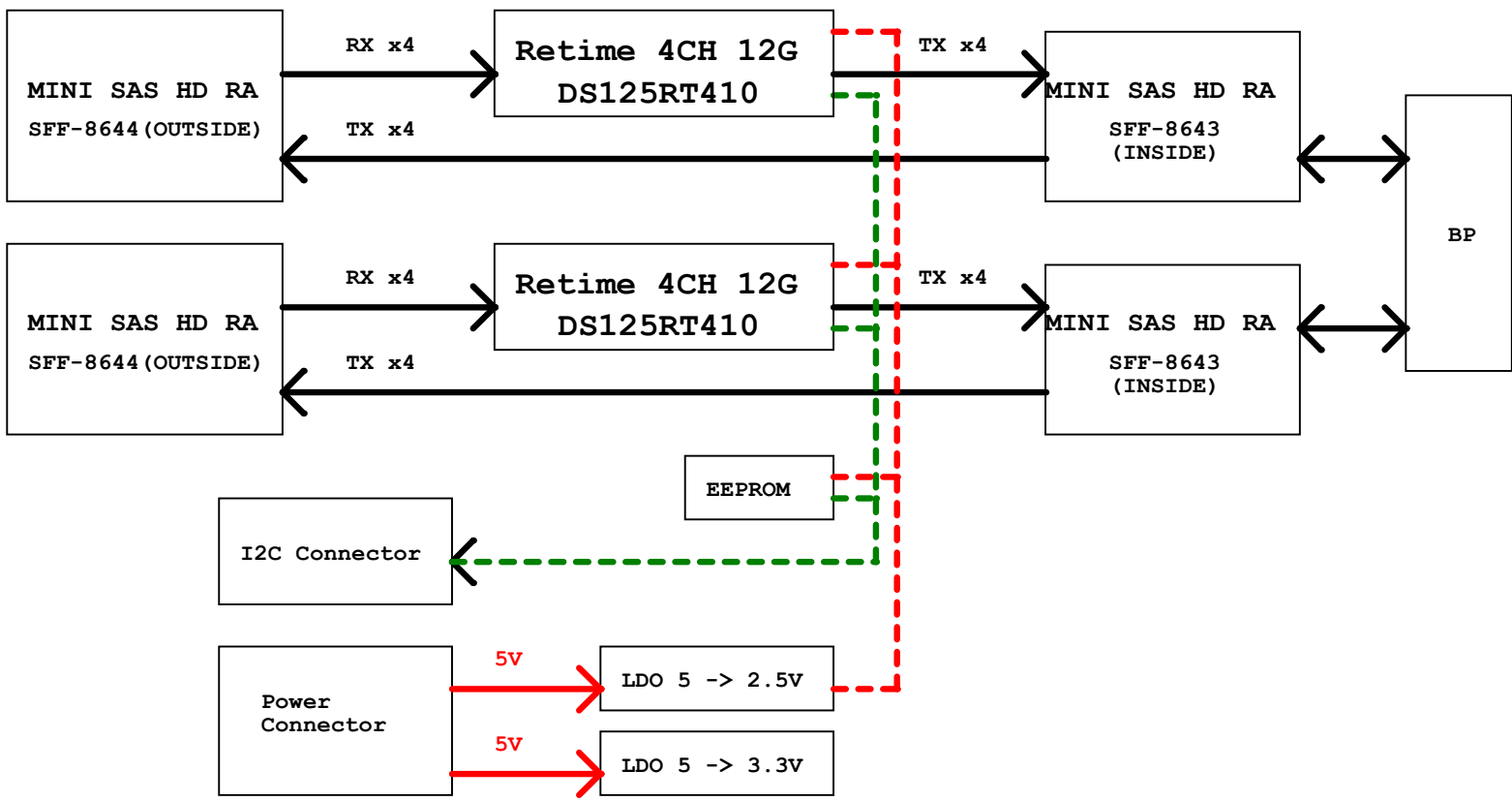

SFF-8644 (Outside)

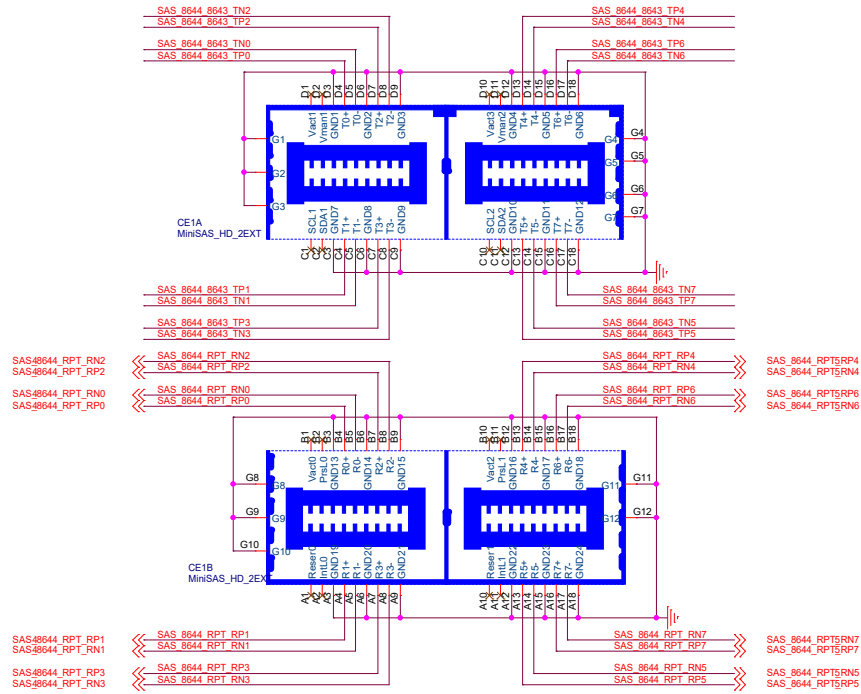

SFF-8643 (Inside)

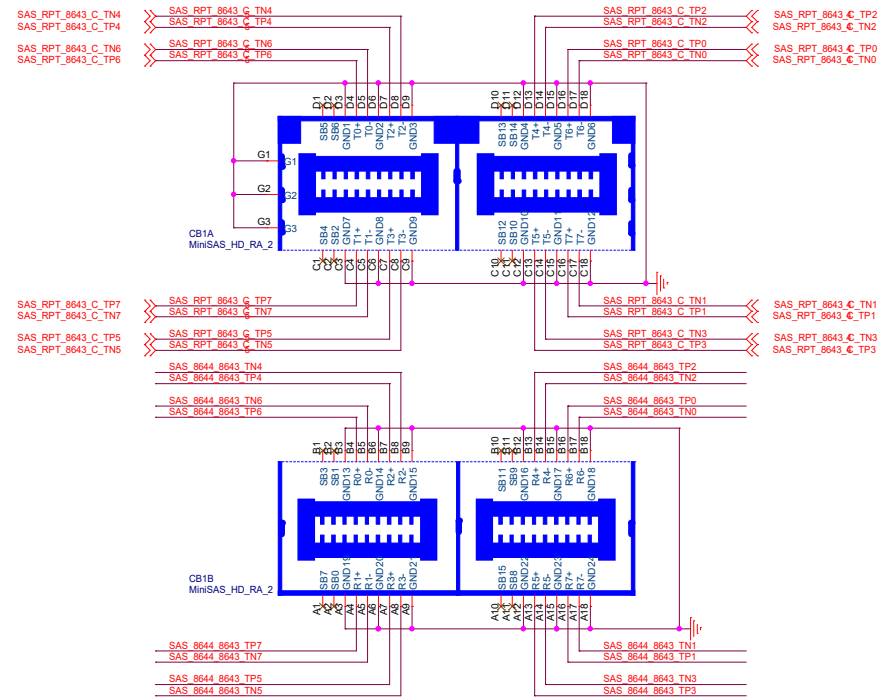

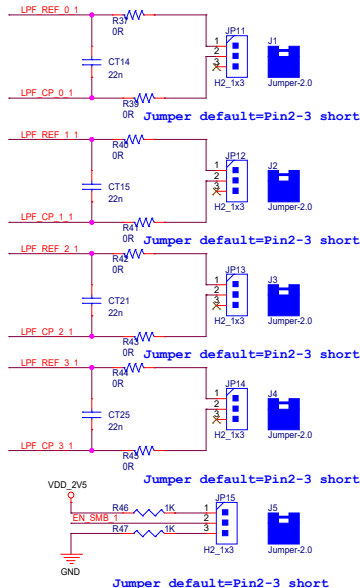
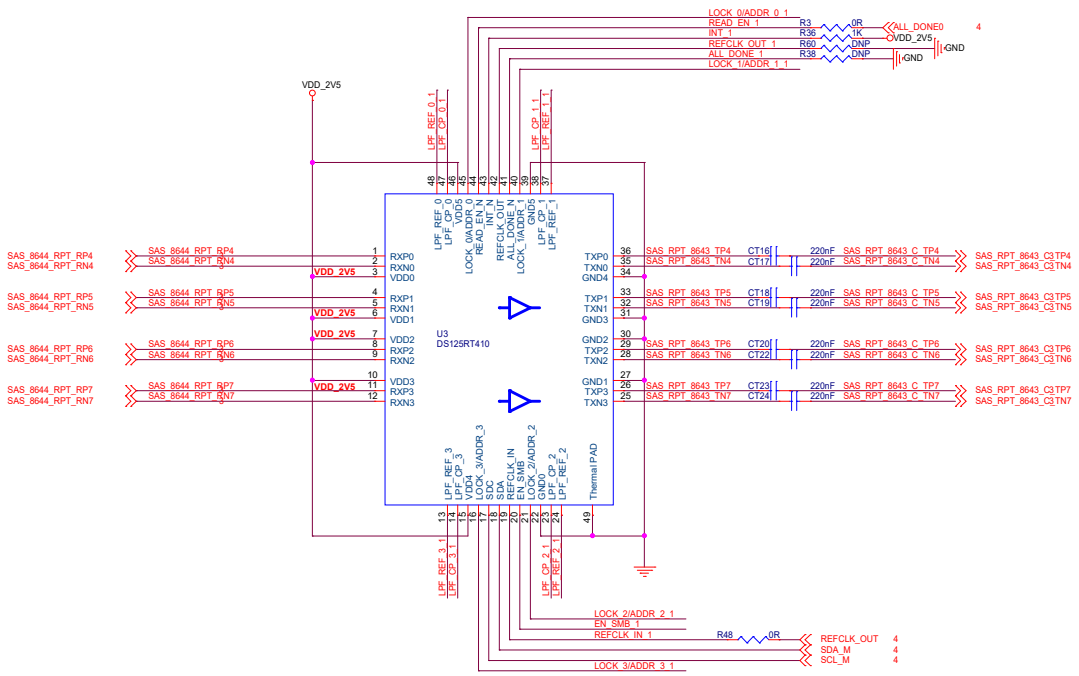

I2C address setting=0001

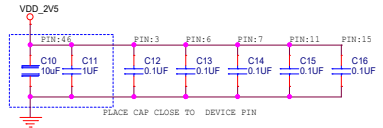
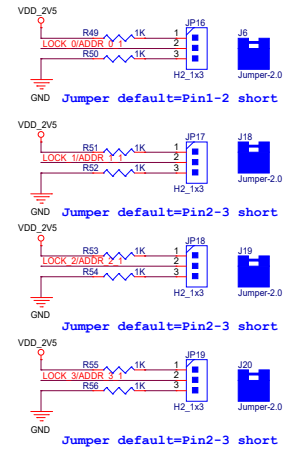

EN_SMB = High for slave mode
 EN_SMB = Float for master mode
 Tie READ_EN pin low for SMBus slave mode.

Table 1. DS125RT410 SMBus Write Address Assignment

ADDR_3	ADDR_2	ADDR_1	ADDR_0	SMBus WRITE ADDRESS	SEVEN-BIT SMBus ADDRESS
0	0	0	0	0x30	0x18
0	0	0	1	0x32	0x19
0	0	1	0	0x34	0x1a
0	0	1	1	0x36	0x1b
0	1	0	0	0x38	0x1c
0	1	0	1	0x3a	0x1d
0	1	1	0	0x3c	0x1e
0	1	1	1	0x3e	0x1f
1	0	0	0	0x40	0x20
1	0	0	1	0x42	0x21
1	0	1	0	0x44	0x22
1	0	1	1	0x46	0x23
1	1	0	0	0x48	0x24
1	1	0	1	0x4a	0x25
1	1	1	0	0x4c	0x26
1	1	1	1	0x4e	0x27