

## Ethernet : RGMII to Copper

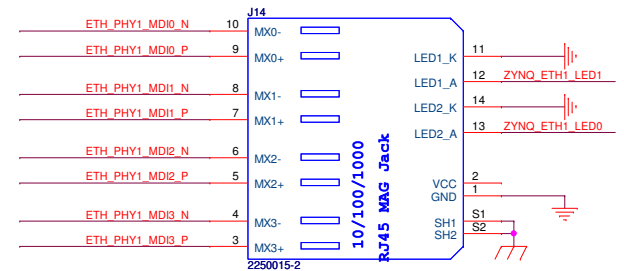
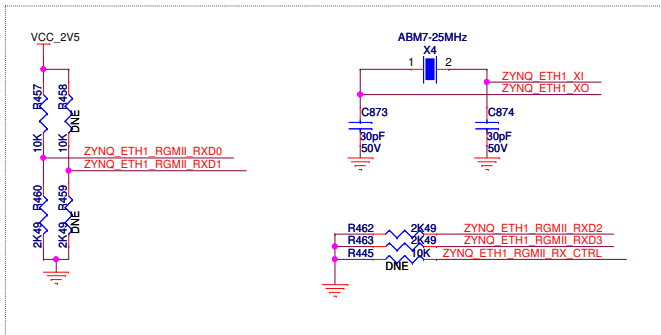
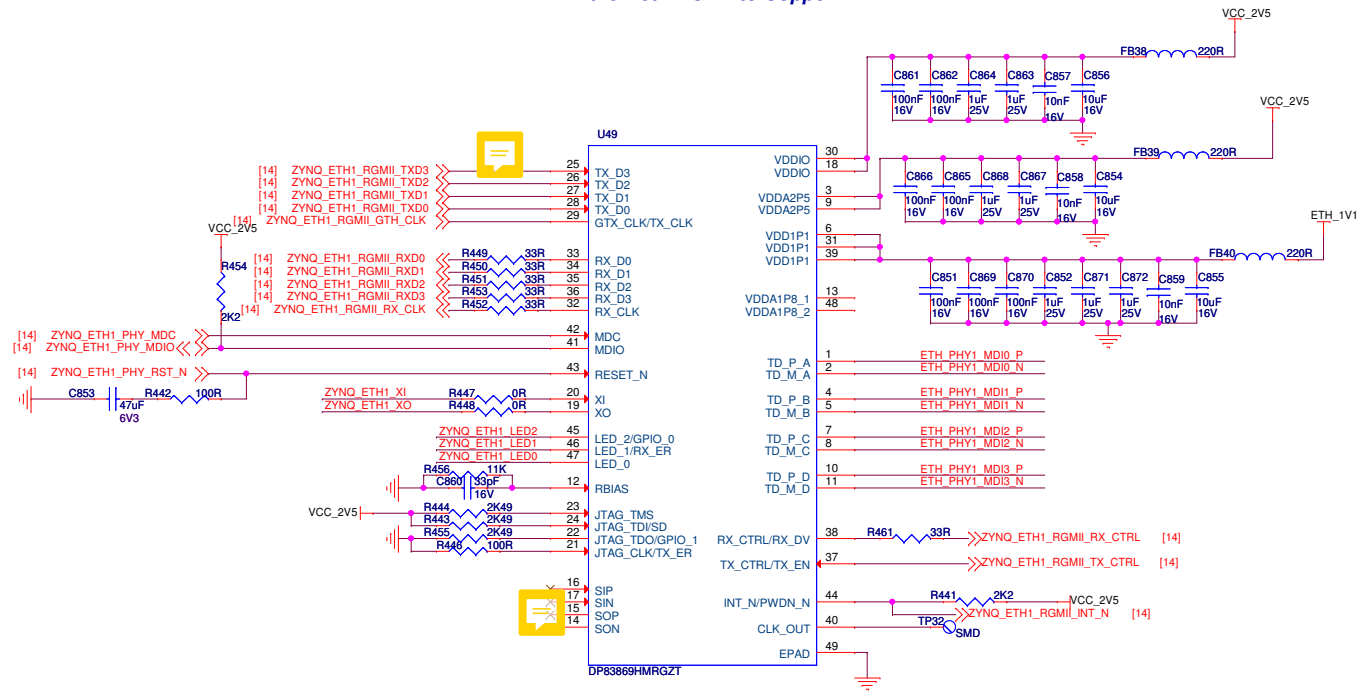

## STRAP OPTIONS

PHY Address : 0000

RX\_D0 = MODE0

RX\_D1 = MODE0

Auto-negotiation, 1000/100/10 advertised, Auto MDI-X

LED [2:0] = 000 [Mode 0]

Functional mode: RGMII to Copper

RX\_D2, RX\_D3 & JTAG\_TDO (2:0) = 000

### Ethernet : RGMII to SGMII

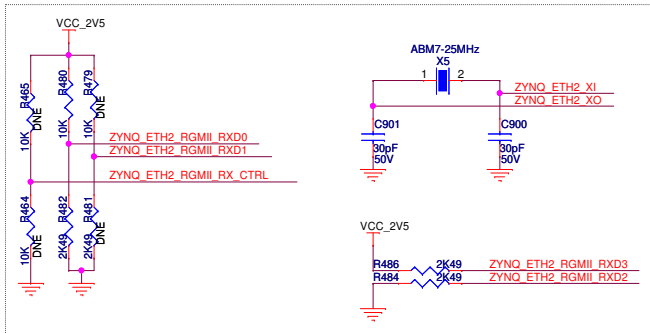
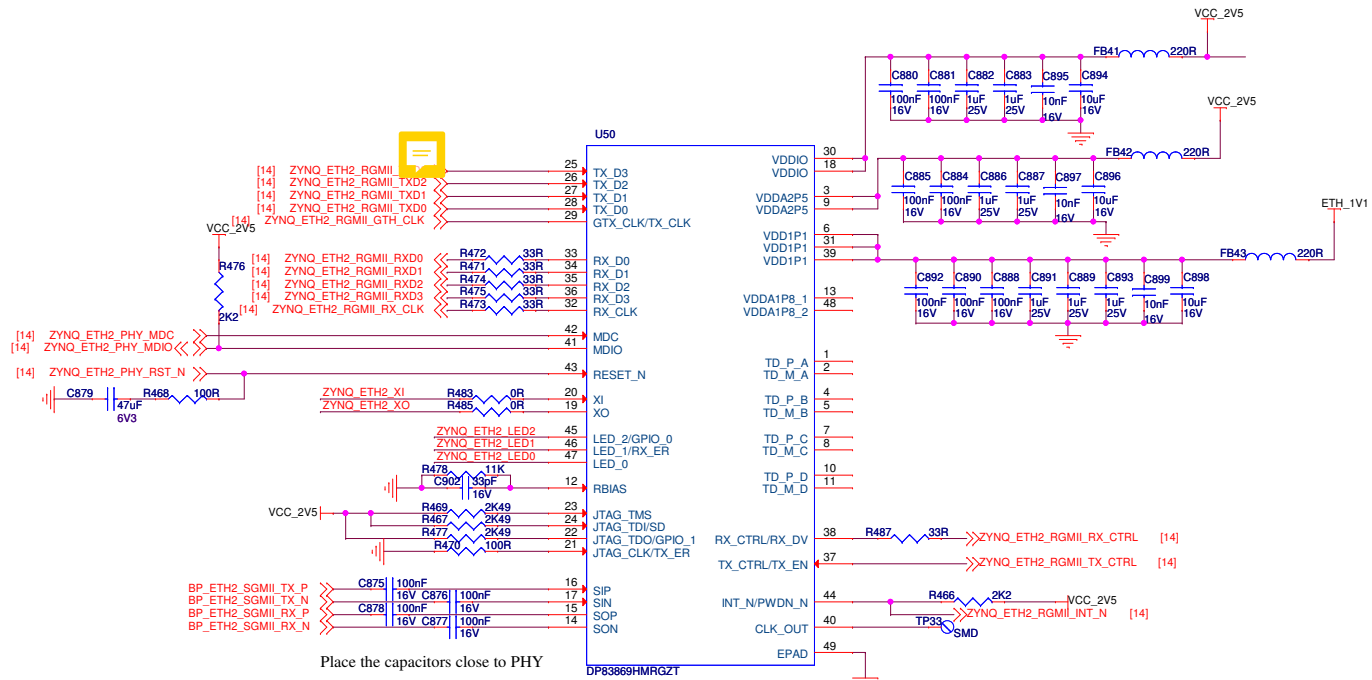

### STRAP OPTIONS

**PHY Address : 0001**

RX\_D0 = MODE1

RX\_D1 = MODE0

**Auto-negotiation, 1000/100/10 advertised, Auto MDI-X**

LED [2:0] = 000 [Mode 0]

**Functional mode: SGMII to RGMII**

RX\_D2, RX\_D3 & JTAG\_TDO (2:0) = 011