

REVISIONS

ECR	ECR NUMBER	DATE
	-----	01/02/13

NOTES:

1. SILKSCREEN ALL JUMPERS AND HEADERS.
2. PLACE ALL PARTS ON A 0 OR 90 DEGREE ORIENTATION.
3. HIGH SPEED SERIAL DATA SHOULD BE ROUTED AS SINGLE-ENDED 50 OHM TRANSMISSION LINES. ROUTING DISTANCE SHOULD BE 3 INCHES OR LESS.
4. USE FR4-370 MATERIAL.
5. PLACE TI LOGO IN TOP SIDE METAL

Texas Instruments and its subsidiaries (TI) reserve the right to make changes to their products and publications or to discontinue any product or service without notice, and advise customers to obtain the latest version of relevant information to verify, before placing orders, that information being relied on is current and complete. All products are sold subject to the terms and conditions of sale supplied at the time of order acknowledgment, including those pertaining to warranty, patent infringement, and limitation of liability.

Customers are responsible for their applications using TI components. In order to minimize risks associated with applications using TI components, adequate design and operating safeguards must be provided by the customer to minimize inherent or procedural hazards. The information in this document is provided by TI as a courtesy and in no way constitutes a reference design. Any direct duplication of this design in its entirety is strictly prohibited without expressed written approval by TI. Furthermore, TI assumes no liability for applications assistance or customer product design. TI does not warrant or represent that any license, either express or implied, is granted under any patent right, copyright, mask work right, or other intellectual property right of TI covering or relating to any combination, machine, or process in which such semiconductor products or services might be or are used. TI's publication or information regarding any third party's products or services does not constitute TI's approval, warranty or endorsement thereof.

Copyright © 2011. Texas Instruments Incorporated



**TEXAS INSTRUMENTS**

SCHEMATIC TITLE  
 HD3SS21X\_1\_2MUX

ENGINEER	DATE	PAGE TITLE			
	11/08/13				
LAYOUT	DATE	SIZE	DOCUMENT NUMBER	REV	SHEET
		B		C	1 of 5
RELEASED	DATE				

NOTE: R111-R126 are placeholders for setting the common mode voltage for device test under DP specific requirements  
 215 HDMI CONNECTOR, DO NOT INPUT R111-- R126

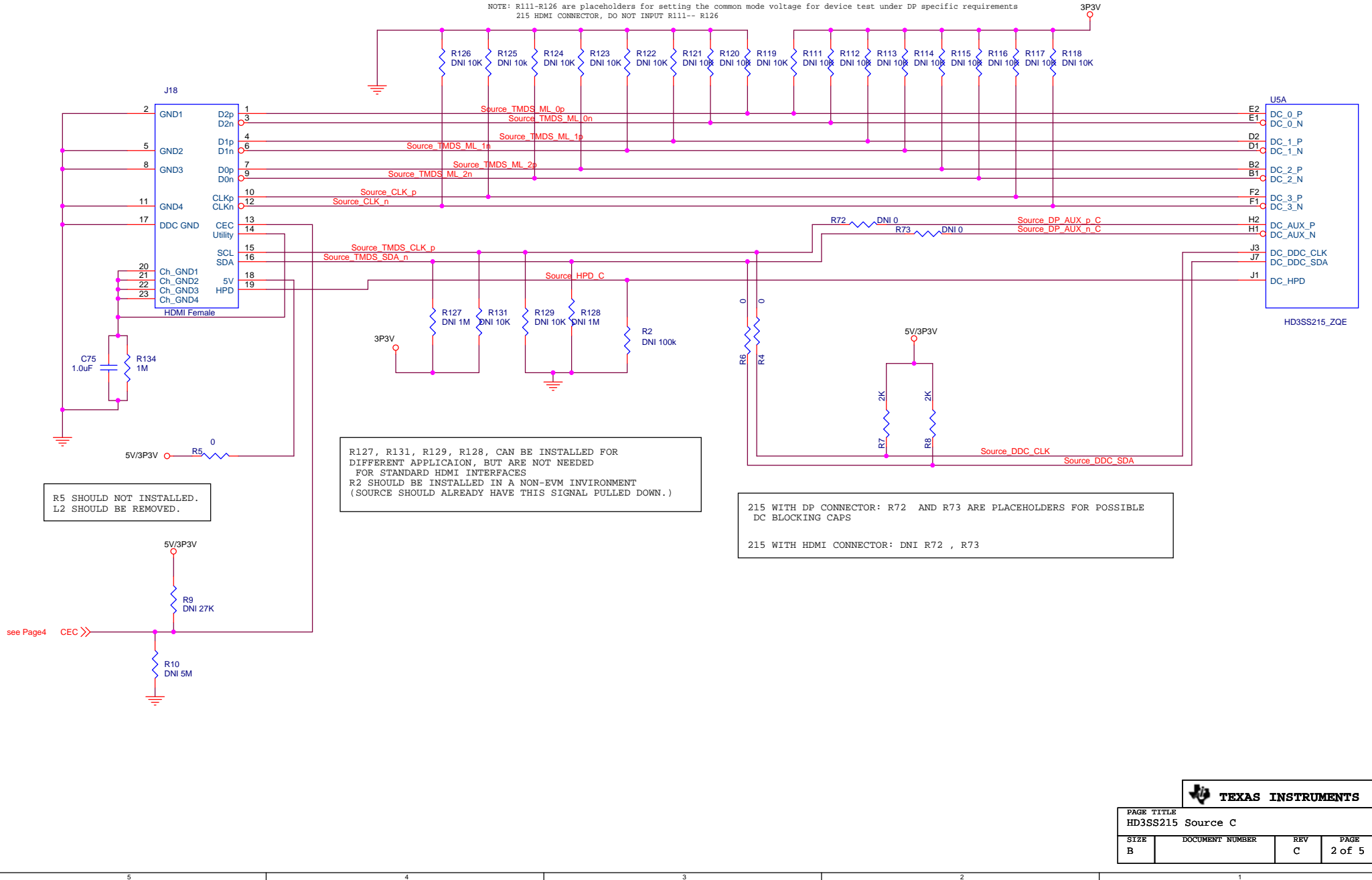

R5 SHOULD NOT INSTALLED.  
 L2 SHOULD BE REMOVED.

R127, R131, R129, R128, CAN BE INSTALLED FOR DIFFERENT APPLICAION, BUT ARE NOT NEEDED FOR STANDARD HDMI INTERFACES  
 R2 SHOULD BE INSTALLED IN A NON-EVM INVIROMENT (SOURCE SHOULD ALREADY HAVE THIS SIGNAL PULLED DOWN.)

215 WITH DP CONNECTOR: R72 AND R73 ARE PLACEHOLDERS FOR POSSIBLE DC BLOCKING CAPS  
 215 WITH HDMI CONNECTOR: DNI R72 , R73

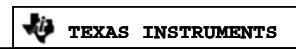

PAGE TITLE			
HD3SS215 Source C			
SIZE	DOCUMENT NUMBER	REV	PAGE
B		C	2 of 5

U5B	DA_0_P	DA_0_N	DA_1_P	DA_1_N	DA_2_P	DA_2_N	DA_3_P	DA_3_N	DA_AUX_P	DA_AUX_N	DA_DDCCLK	DA_DDCDAT	DA_HPD
	B4	A4	B5	A5	B6	A6	B7	A7	H9	J9	H8	J8	J2
	B8	B9	D8	D9	E8	E9	F8	F9	H6	J6	H5	J5	H3

R49, R57, R58, R59, R60, R61, R62, AND R63 ARE  
PLACEHOLDERS FOR POSSIBLE  
DC BLOCKING CAPS IF NEEDED

R64, R65, R66, R67, R68, R69, R70, AND R71 ARE  
PLACEHOLDERS FOR POSSIBLE  
DC BLOCKING CAPS IF NEEDED

R44, R20 can be installed to provide 5V on DDC and CEC

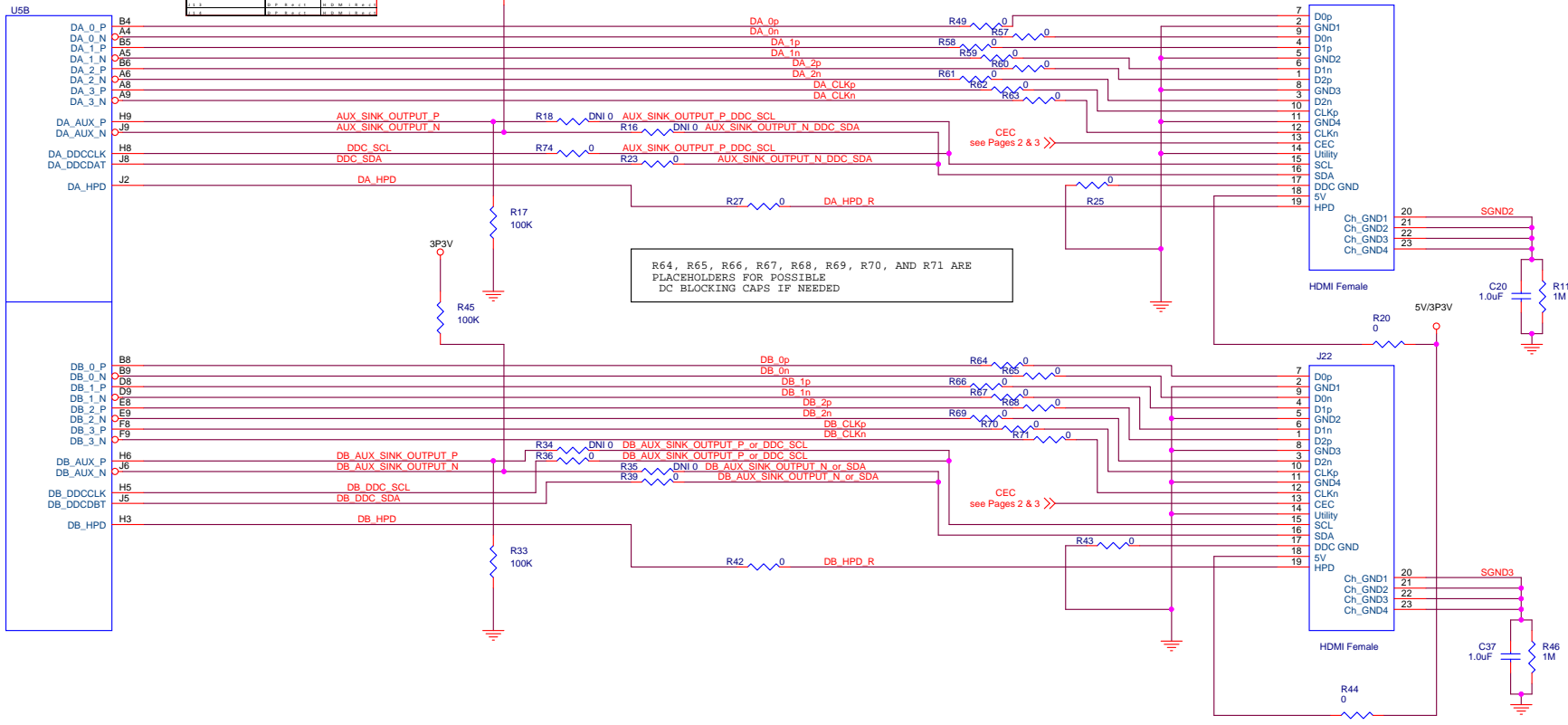

HD3SS215\_ZOE

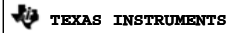

PAGE TITLE			
HD3SS215 Sink Port A and B			
SIZE	DOCUMENT NUMBER	REV	PAGE
Custom		C	3 of 5

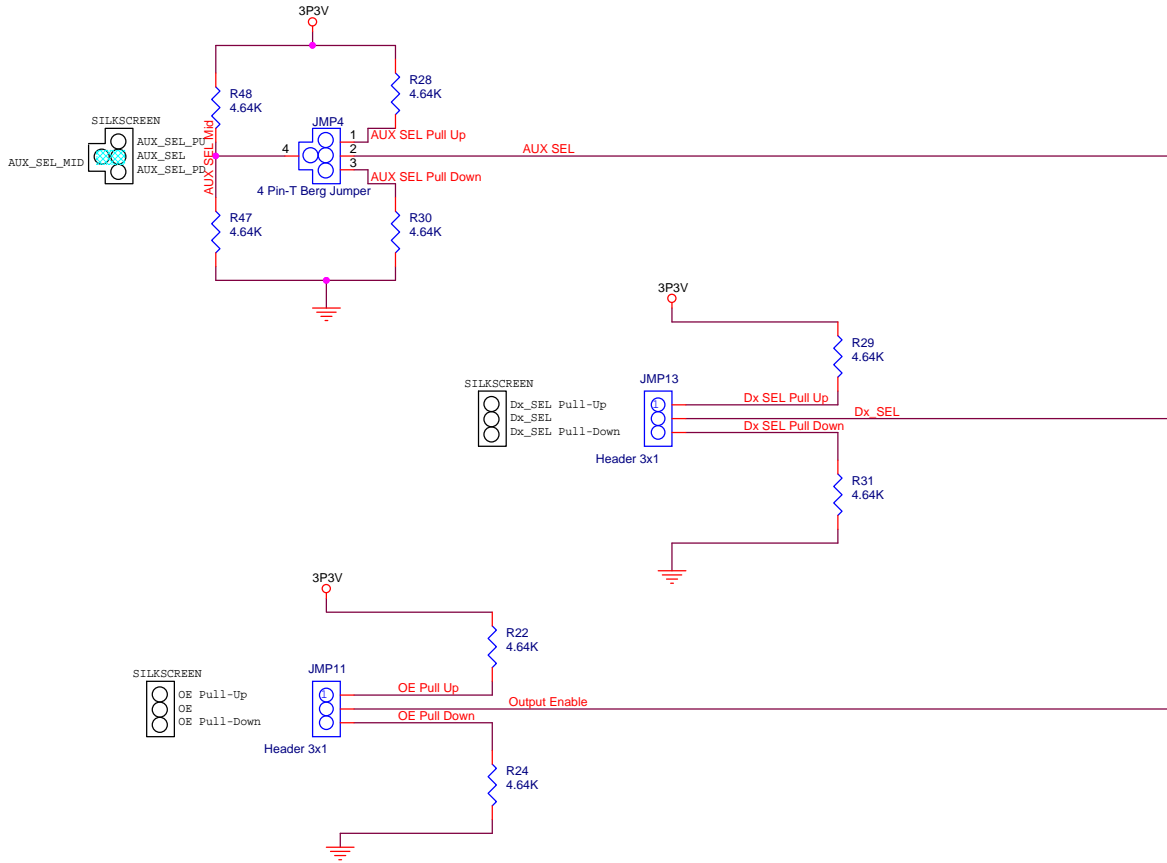

**Switch Control Logic**

Control Lines	Switched I/O Pins			
	Dx_SEL	DCz(p) Pin z=0, 1, 2 or 3	DCz(n) Pin z=0, 1, 2 or 3	HPDC Pin
L	DAz(p)	DAz(n)	HPDA	CADA
H	DBz(p)	DBz(n)	HPDB	CADB

OE pin - For normal operation, drive OE high. Driving the OE pin low will disable the switch to  
 Note: The ports which are not selected by the Control Lines will be in High Impedance State.

**AUX/DDC Switch Control Logic**

Control Lines		Switched I/O Pins			
AUX_SEL	Dx_SEL		AUXA	AUXB	AUXC
L	L	213/215	To/From AUXC	Z	To/From AUXA
L	H	213/215	Z	To/From AUXC	To/From AUXB
H	L	213/215	Z	Z	To/From DDCA
H	H	213/215	Z	Z	To/From DDCB
M		213	To/From DDCC	Z	Z

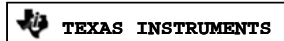

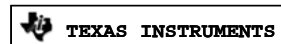
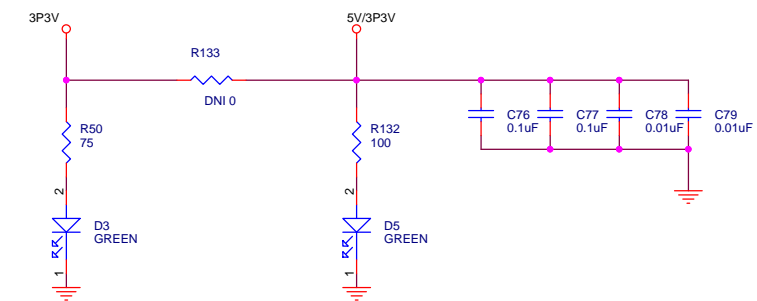
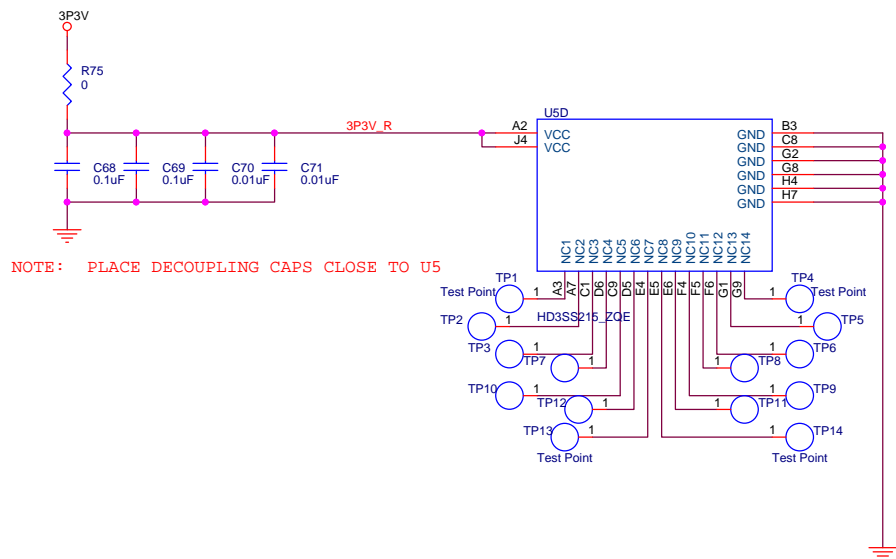
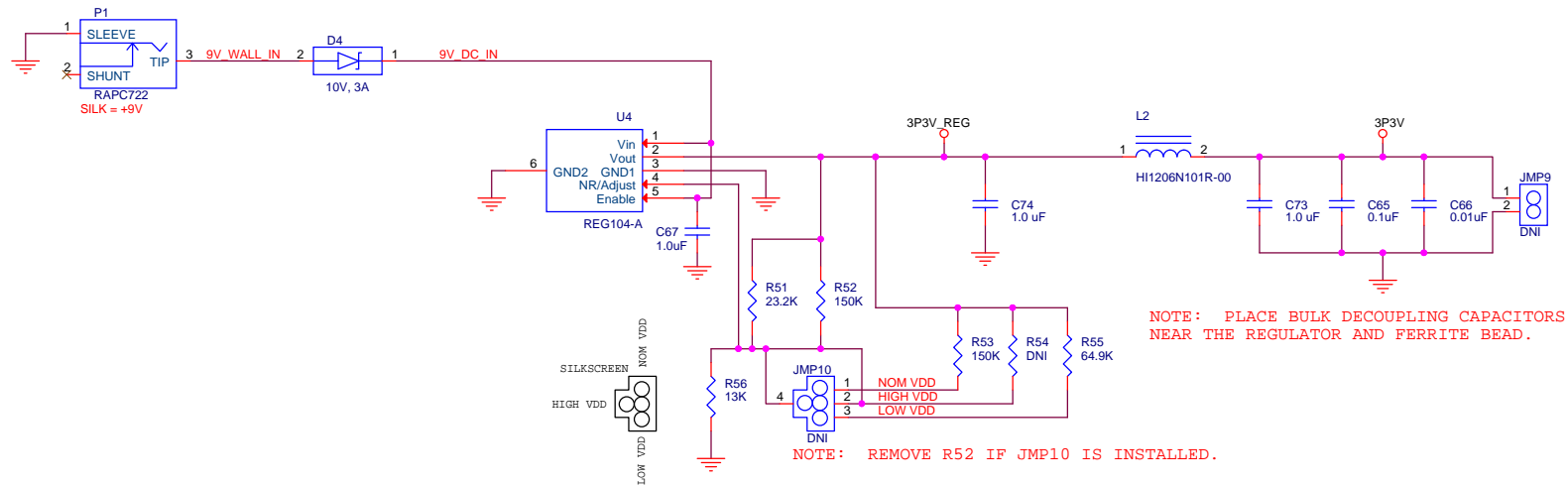

PAGE TITLE			
POWER			
SIZE	DOCUMENT NUMBER	REV	PAGE
B		C	5 of 5