

3V3SUS
 3V3SUS

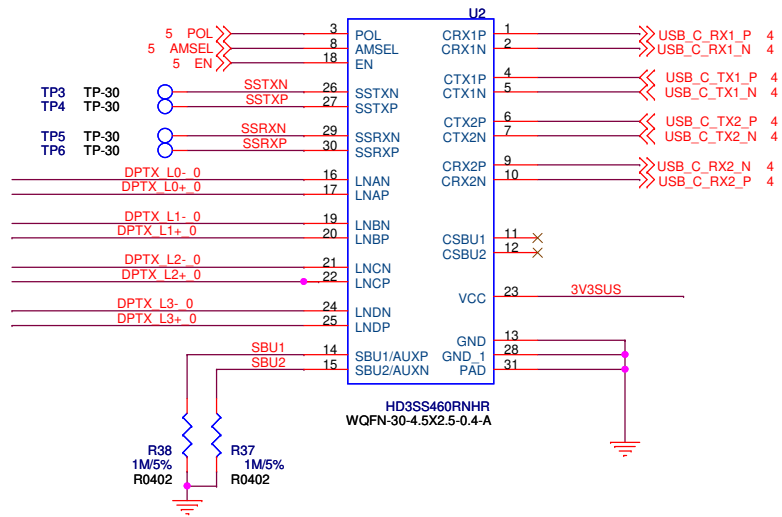

Title		
<Title>		
Size	Document Number	Rev
B	<Doc>	<RevCode>
Date:	Monday, February 18, 2019	Sheet 1 of 1

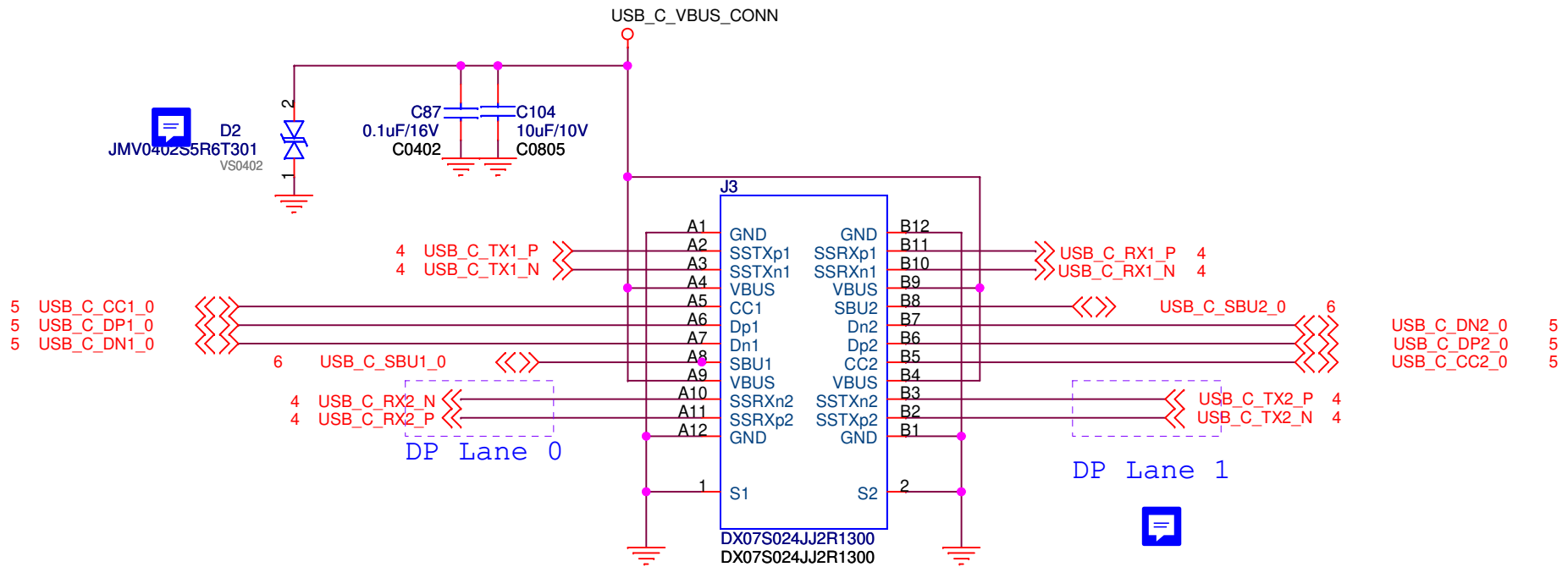

JORJIN SPECIALTY ELECTRONIC COMPONENTS		
Title Coaxial Cable Connector		
Size A	Document Number J4H USB Board	Rev D01
Date:	Monday, February 18, 2019	Sheet 2 of 6

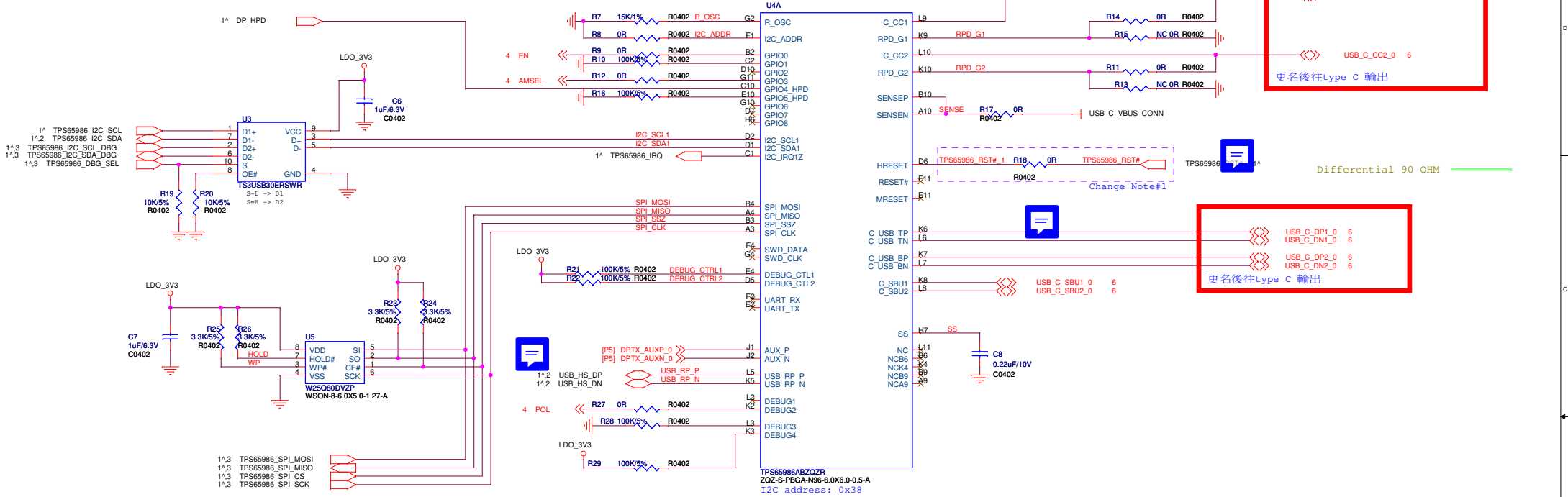

It will be change into 12V input

JOR&JID		
File USB Type C		
Size	Document Number	Rev
Custom	J4H USB Board	D01
Date:	Monday, February 18, 2019	Sheet 5 of 6

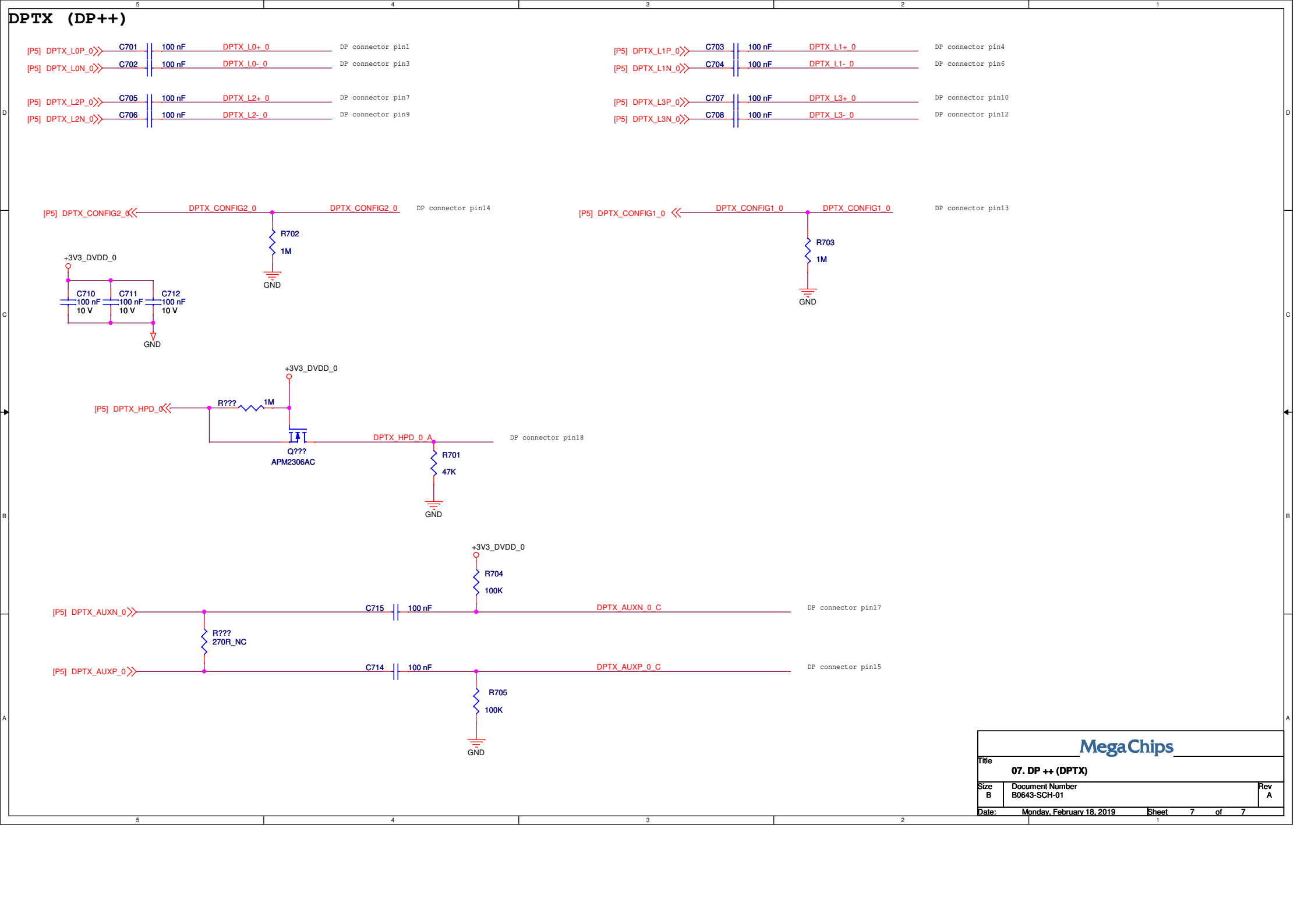

MegaChips		
Title		
07. DP ++ (DPTX)		
Size	Document Number	Rev
B	B0643-SCH-01	A
Date:	Monday, February 18, 2019	Sheet 7 of 7