

Title		
Signal reception transmitted board		
Size	Document Number	Rev
A3		1
Date:	Thursday, August 04, 2022	Sheet 1 of 3

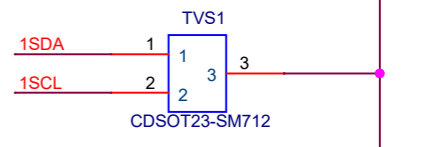

Title		<Title>
Size	Document Number	Rev
A3	<Doc>	<RevC>
Date:	Thursday, August 04, 2022	Sheet 2 of 3

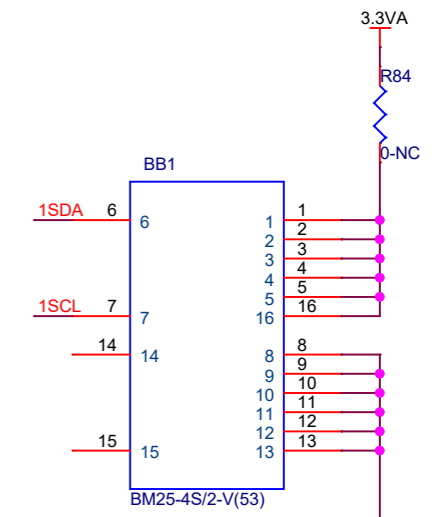
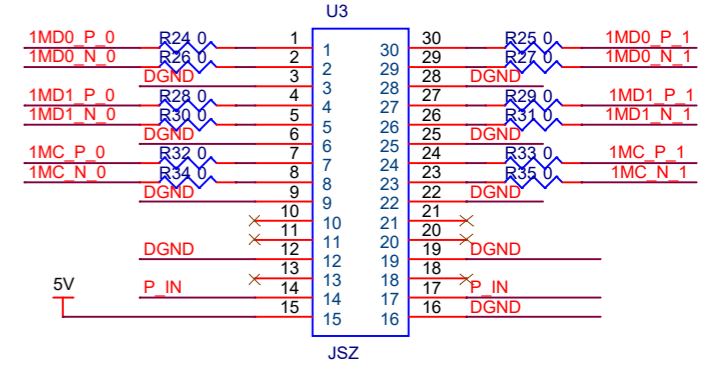
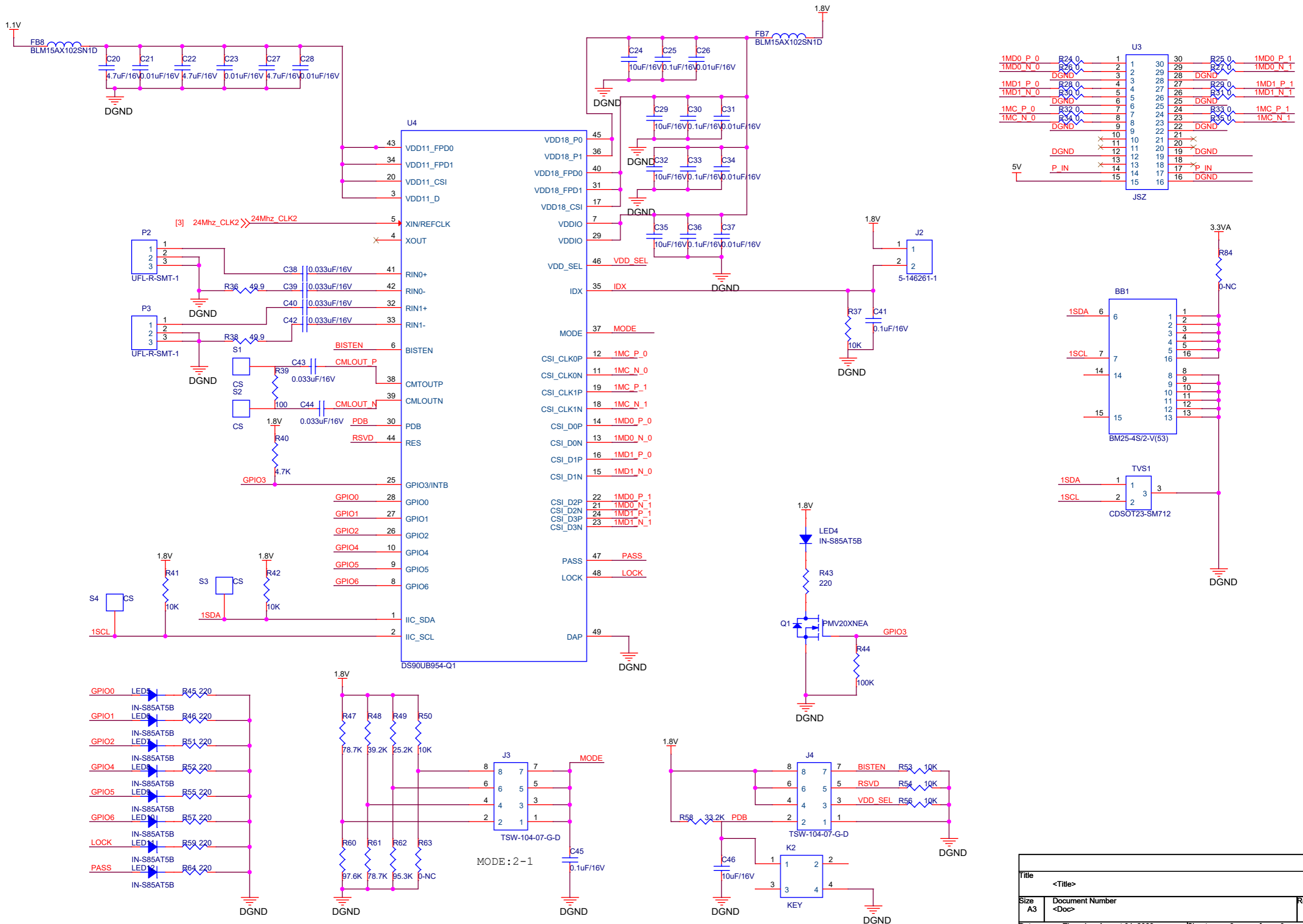
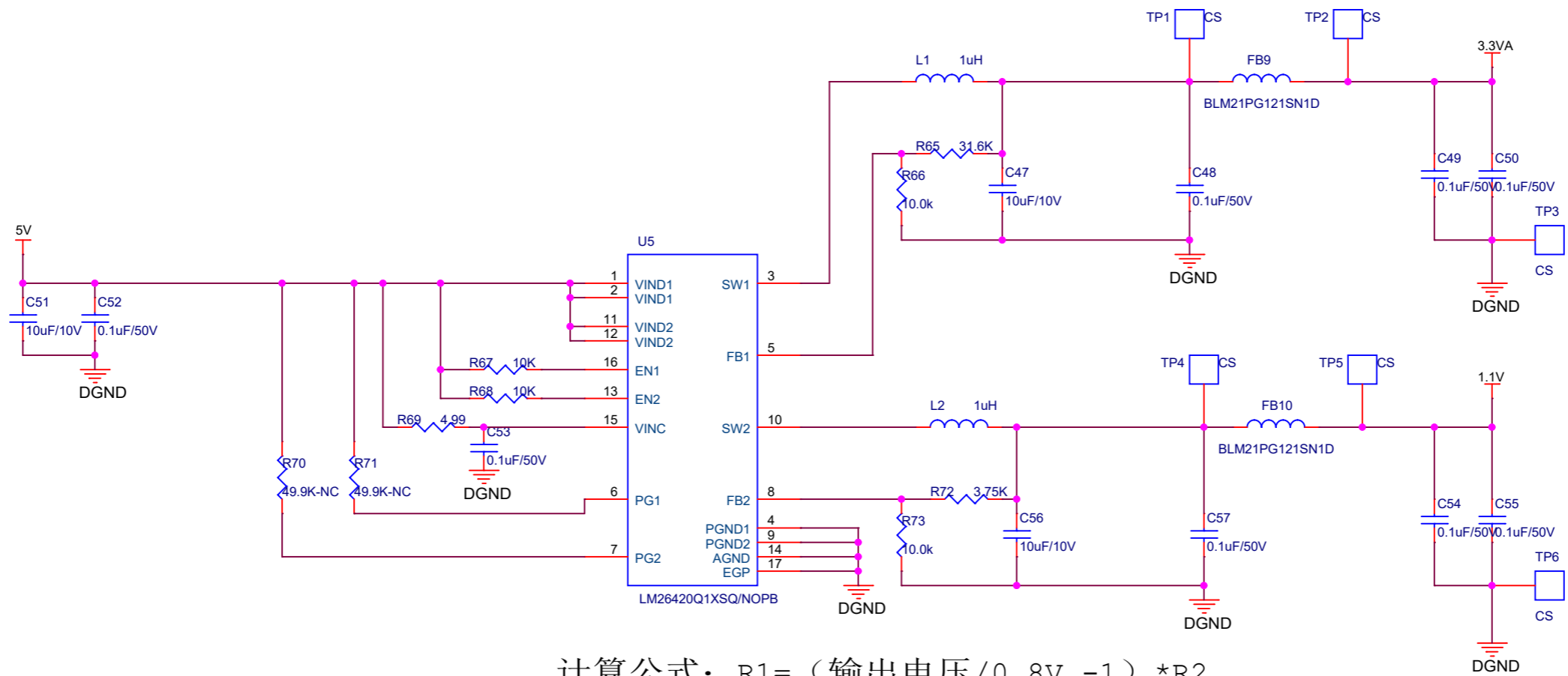

计算公式:  $R1 = (\text{输出电压} / 0.8V - 1) * R2$

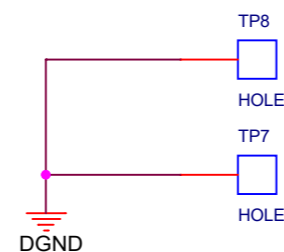
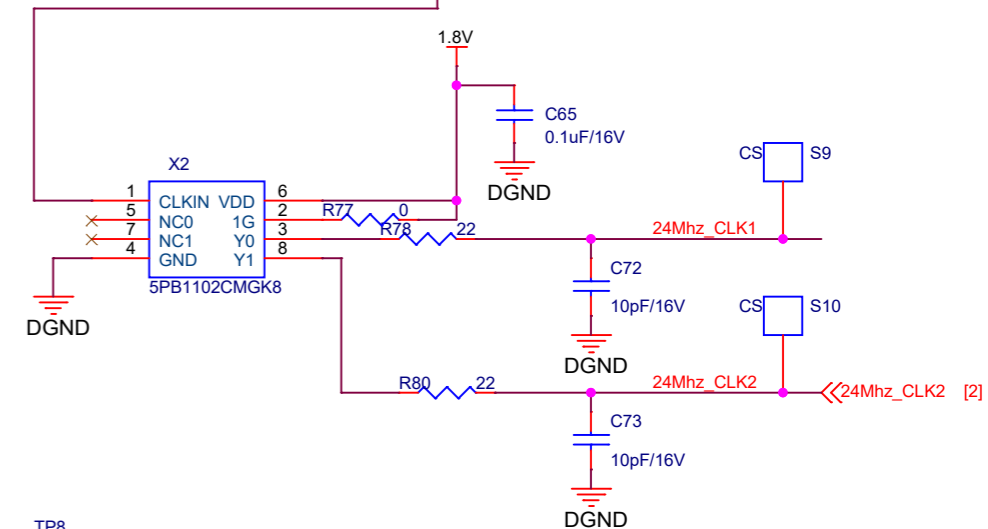
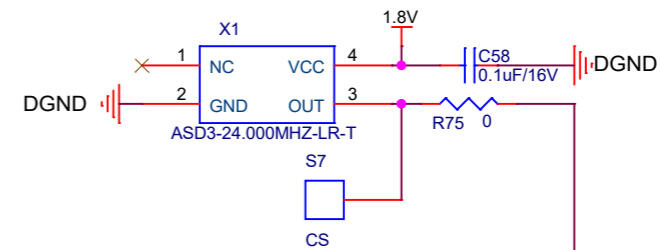
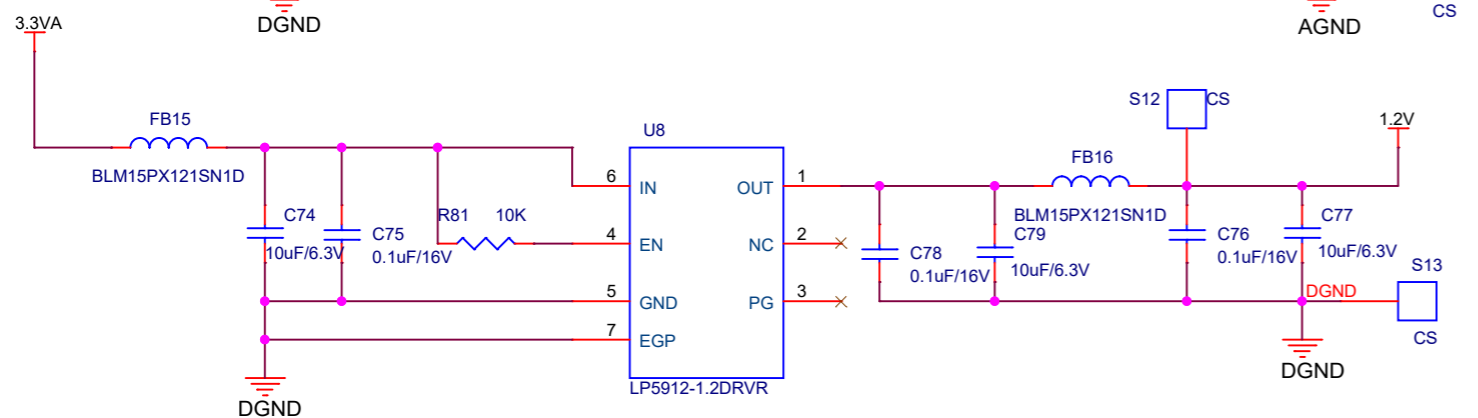
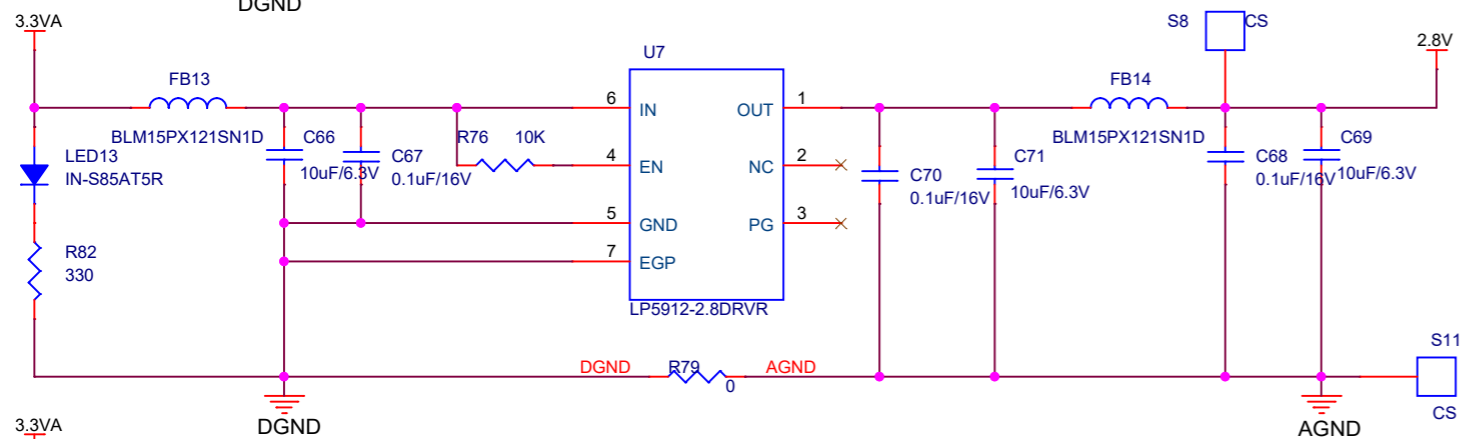
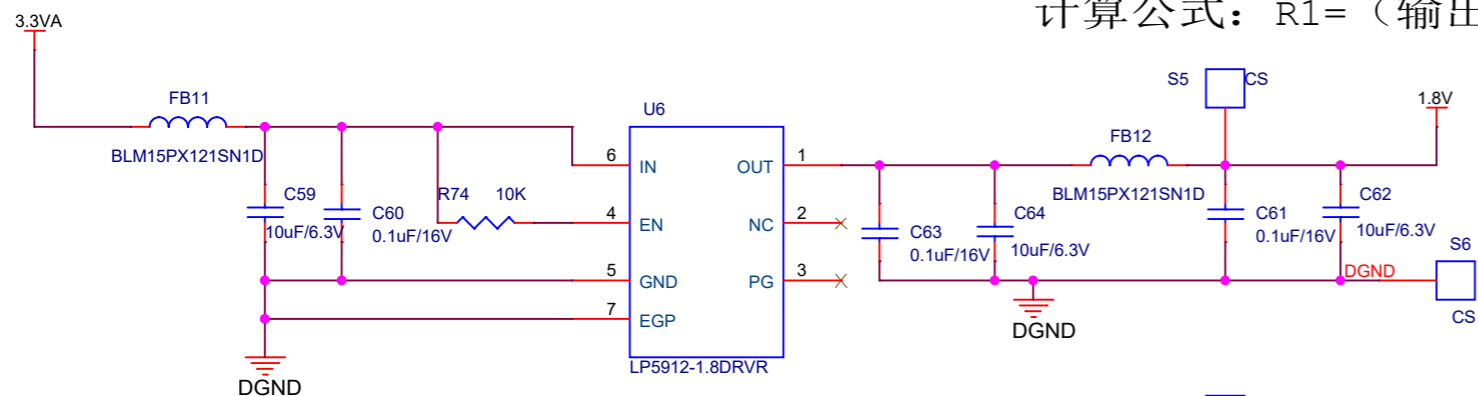

Title		
<Title>		
Size	Document Number	Rev
A3	<Doc>	<RevC>
Date:	Monday, March 14, 2022	Sheet 3 of 3