

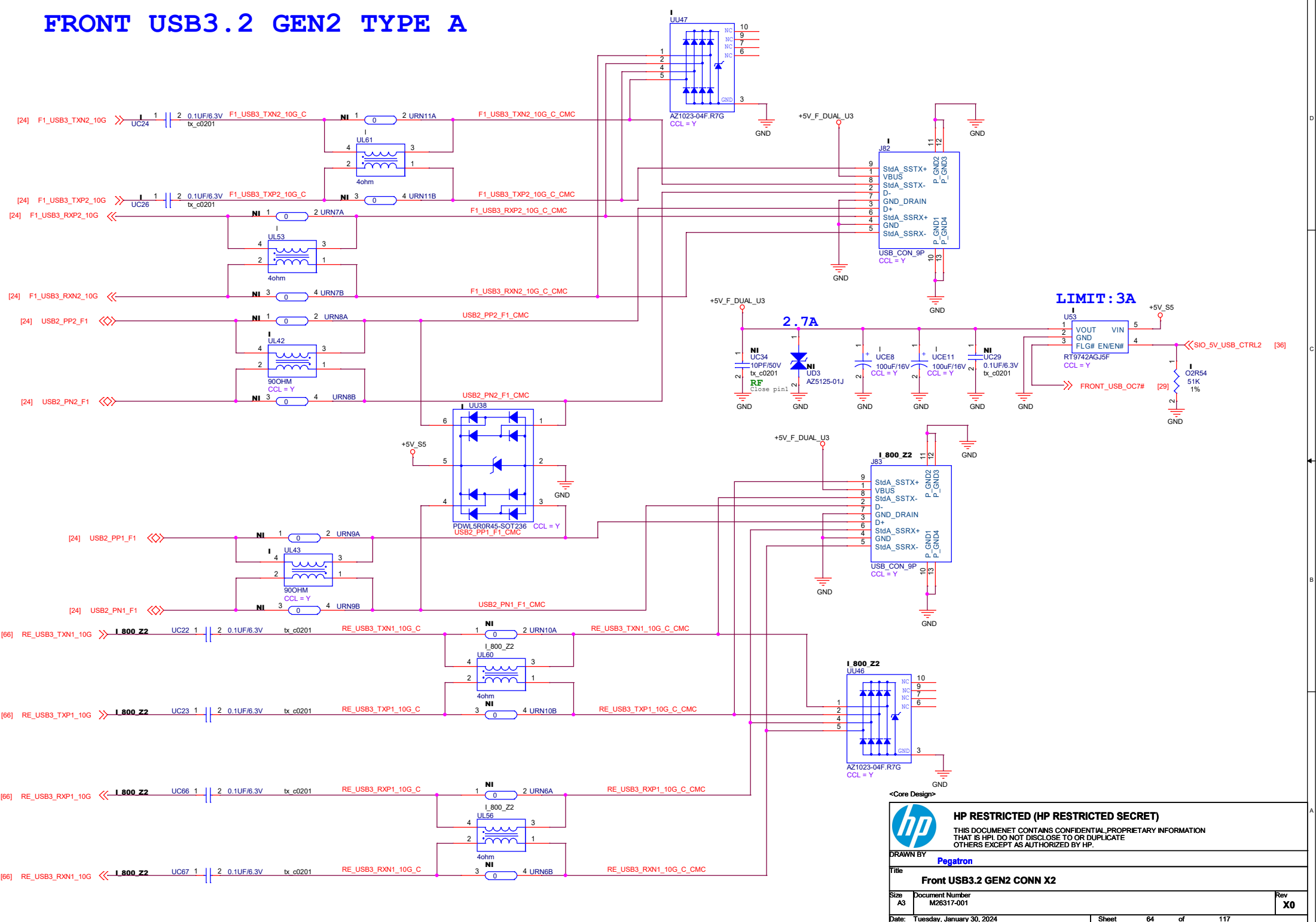

FRONT USB3.2 GEN2 TYPE A



<Core Design>



HP RESTRICTED (HP RESTRICTED SECRET)

THIS DOCUMENT CONTAINS CONFIDENTIAL, PROPRIETARY INFORMATION THAT IS HPL DO NOT DISCLOSE TO OR DUPLICATE OTHERS EXCEPT AS AUTHORIZED BY HP.

DRAWN BY **Pegatron**

Title **Front USB3.2 GEN2 CONN X2**

Size A3	Document Number M26317-001	Rev X0
Date: Tuesday, January 30, 2024	Sheet 64 of 117	

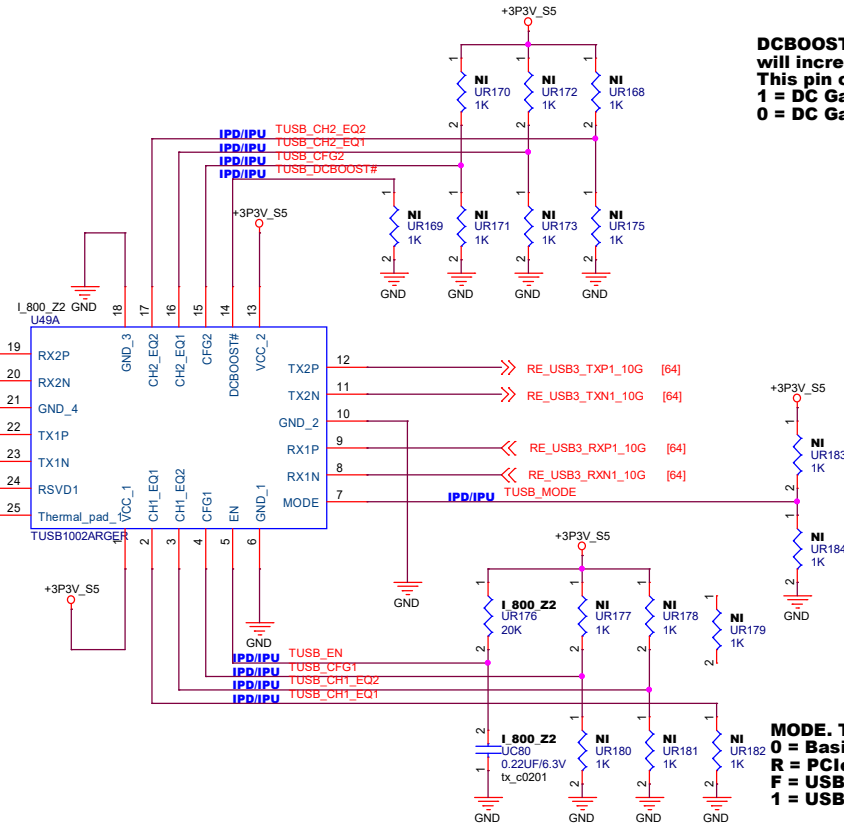
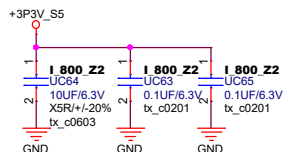

DCBOOST#. This pin when asserted low will increase the DC Gain level +1 dB unless already at +2dB. This pin can be left unconnected if this function is not needed.
1 = DC Gain defined by Table 3.
0 = DC Gain defined by Table 3 is increased by +1 dB

Table 2. EQ Configuration Options for 1200mV Linearity 0 dB DC Gain Setting

EQ SETTING #	CH ₁ EQ2 PIN LEVEL	CH ₂ EQ1 PIN LEVEL	EQ GAIN at 2.5GHz / 5 GHz (dB)
1	0	0	1.0/3.6
2	0	R	2.1/5.5
3	0	F	3.0/6.8
4	0	1	4.0/8.1
5	R	0	4.6/9.0
6	R	R	5.5/10.0
7	R	F	6.2/10.8
8	R	1	6.9/11.6
9	F	0	7.3/11.9
10	F	R	7.9/12.6
11	F	F	8.4/13.1
12	F	1	9.0/13.7
13	1	0	9.4/14.1
14	1	R	9.9/14.6
15	1	F	10.3/14.9
16	1	1	10.7/15.3

Table 1. 4-Level Control Pin Settings

LEVEL	SETTINGS
0	Option 1: Tie 1 kΩ 5% to GND. Option 2: Tie directly to GND.
R	Tie 20 kΩ 5% to GND.
F	Float (leave pin open)
1	Option 1: Tie 1 kΩ 5% to V _{CC} . Option 2: Tie directly to V _{CC} .

MODE. This pin is for selecting different modes of operation.
0 = Basic Redriver Mode.
R = PCIe / Test Mode. PCIe Mode and TI Internal use only
F = USB3.2 x1 Dual Channel Operation enabled (TUSB1002A normal mode).
1 = USB3.2 x1 Single-channel operation.

Table 3. VOD Linear Range and DC Gain

SETTING #	CFG1 PIN LEVEL	CFG2 PIN LEVEL	CH1 DC GAIN (dB)	CH2 DC GAIN (dB)	CH1 V _{OD} LINEAR RANGE (mVpp)	CH2 V _{OD} LINEAR RANGE (mVpp)
1	0	0	+1	0	900	900
2	0	R	0	+1	900	900
3	0	F	0	0	900	900
4	0	1	+1	+1	900	900
5	R	0	0	0	1000	1000
6	R	R	+1	0	1000	1000
7	R	F	0	-1	1000	1000
8	R	1	+2	+2	1000	1000
9	F	0	-1	-1	1200	1200
10	F	R	+2	+2	1200	1200
11	F	F	0	0	1200	1200
12	F	1	+1	+1	1200	1200
13	1	0	+2	0	1200	1200
14	1	R	0	+2	1200	1200
15	1	F	0	+1	1200	1200
16	1	1	+1	0	1200	1200

<Core Design>

HP RESTRICTED (HP RESTRICTED SECRET)

THIS DOCUMENT CONTAINS CONFIDENTIAL, PROPRIETARY INFORMATION THAT IS HPL DO NOT DISCLOSE TO OR DUPLICATE OTHERS EXCEPT AS AUTHORIZED BY HP.

DRAWN BY **Pegatron**

Title **USB Redriver 1**

Size A3	Document Number M26317-001	Rev X0
Date: Tuesday, January 30, 2024	Sheet 66 of 117	