

Is it a right mangement for the EEPROM?

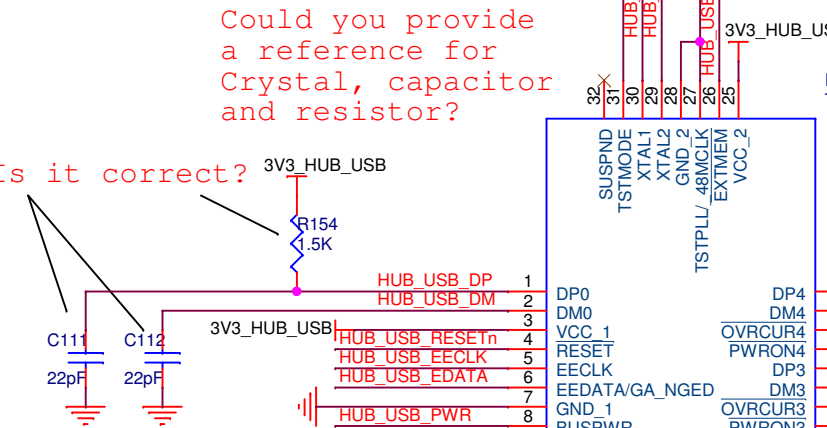

Is it correct?

Could you provide a reference for Crystal, capacitor and resistor?

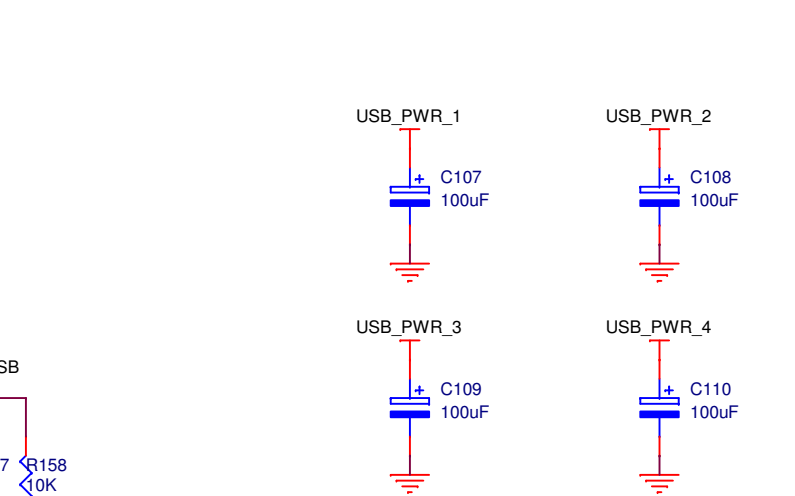
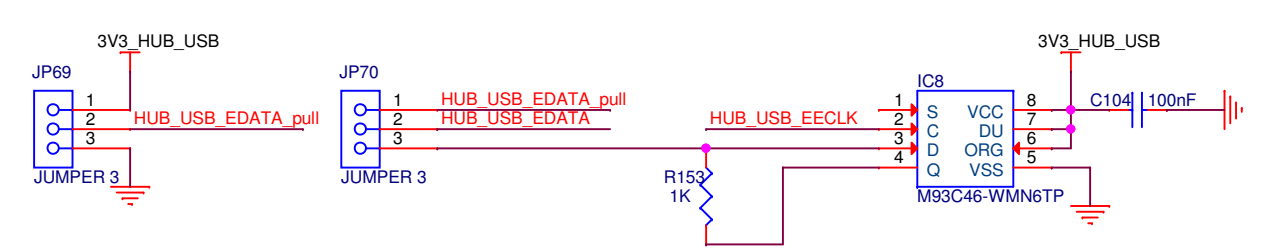
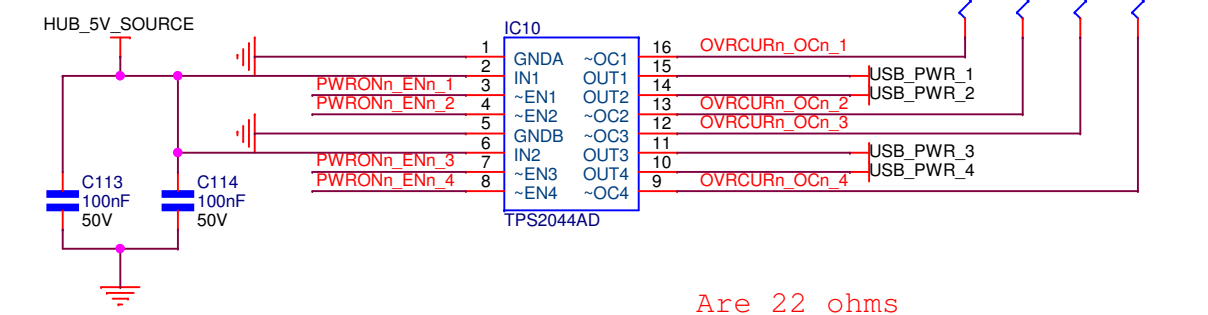

Is it correct?

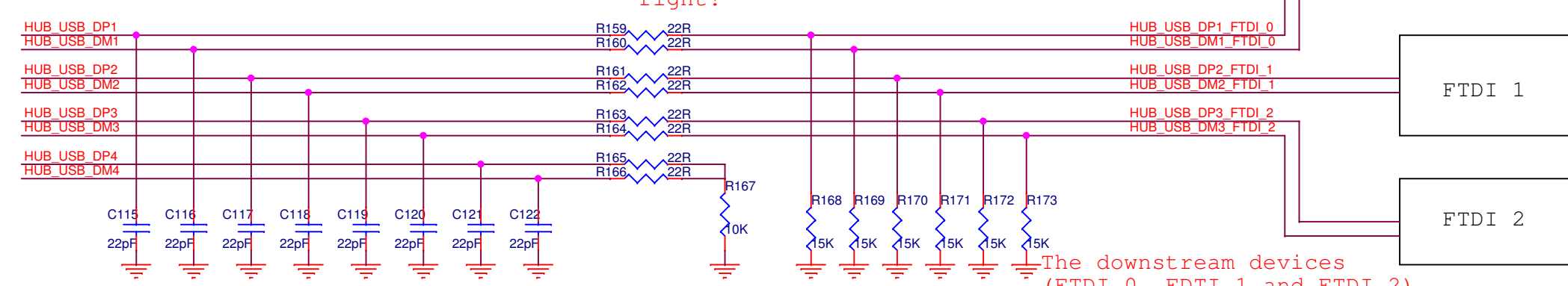
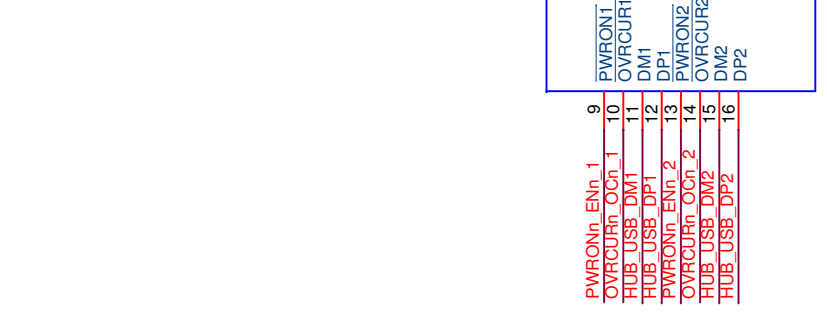

Are 22 ohms right?

The downstream devices (FTDI 0, FTDI 1 and FTDI 2) will be mounted on this board (the same where are the current HUB): in this case are other ESD protection required? Or can I connet it directly?

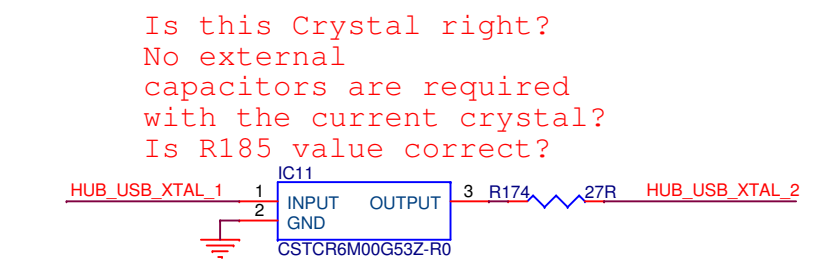

Is this Crystal right? No external capacitors are required with the current crystal? Is R185 value correct?

Note for user:
Keep JGx closed between 2-3 to use 3V3 from USB
Keep JGy closed between 1-2 to use 3V3 from the board

Solder jumper for self-power or bus power selection. Is it right?

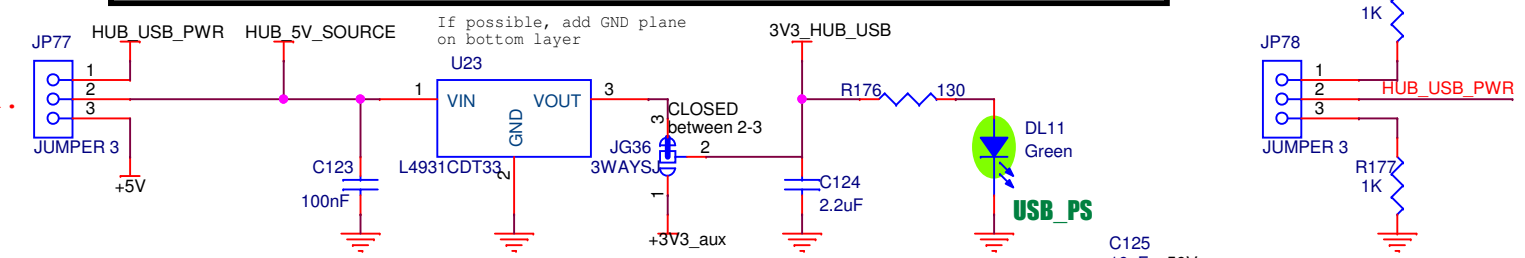

Note for user:
For the bus-power mode, this terminal must be pulled to 3.3 V, and for the self-powered mode, this terminal must be pulled low.

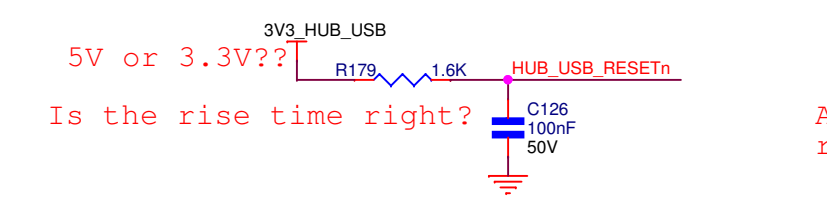

5V or 3.3V???

Is the rise time right?

Are 22 ohms right?

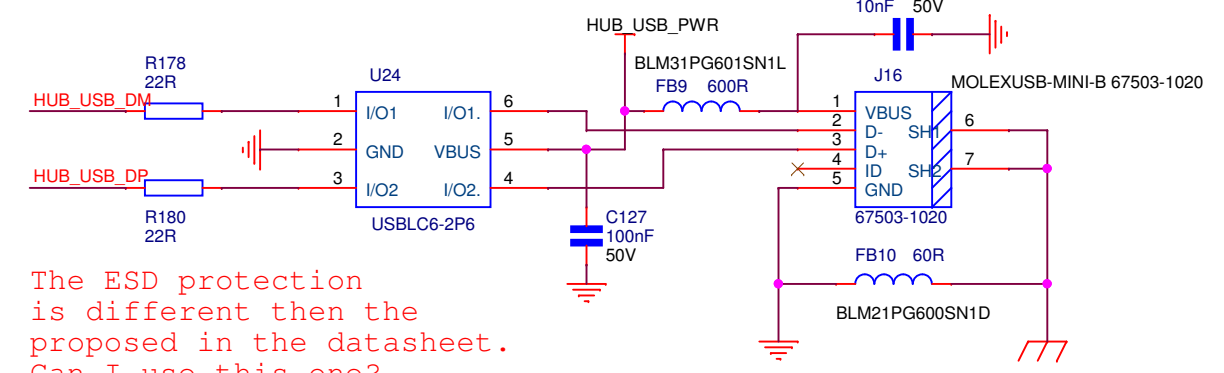

The ESD protection is different then the proposed in the datasheet. Can I use this one?

Title		
Size A3	Document Number <Doc>	Rev 1.5
Date: Thursday, May 28, 2020	Sheet 9	of 10