

## RS-232-to-RS-485 Converters used in Industrial Long-haul Communication

Industrial data links requiring the transmission of RS-232 data over long distance, or between multiple RS-232 applications, often utilize RS-232 to RS-485 converters. Despite the high signal swing of up to  $\pm 13\text{V}$ , RS-232 is an unbalanced, or single-ended interface and as such highly susceptible to noise. Its bus maximum length is therefore limited to about 20m (60 ft). While allowing for full-duplex data transmission, that is transmitting and receiving data at the same time via separate signal conductors, RS-232 does not support the connection of multiple nodes on the same bus.

In strong contrast, RS-485 is a balanced interface using differential signaling, which makes it highly immune to common-mode noise. Therefore, extending an RS-232 data link over long distance and enabling the connections of multiple bus nodes requires the conversion to RS-485 signals via interface converters (see **Figure 1**).

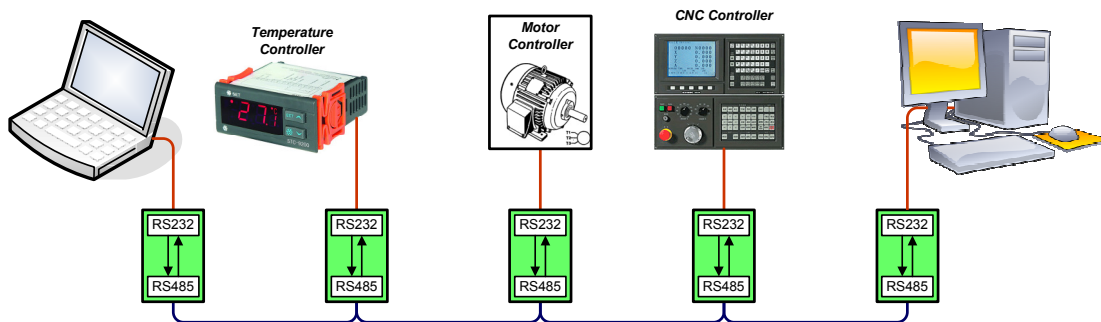

**Figure 1.** Converting short distance, point-to-point data links into a long distance, multi-point network.

**Figure 2** shows the schematic of a low-power, isolated converter design. Here the RS-232 serial port of a personal computer (PC) for example, connects to the SUB-D9 female connector on the left.

The PC serial port contains a RS-232 driver and receiver chip that converts its internal 5V logic signals to the higher  $\pm 8\text{V}$  to  $\pm 13\text{V}$  levels at the connector. These high-voltage bus signals are converted back to standard logic levels via another RS-232 chip in order to communicate with the RS-485 transceiver.

In transmit direction the 485-transceiver converts the logic signals from the RS-232 receiver output into differential bus signals. In receive direction, it converts the differential bus signals into single-ended, low-volt signals entering the RS-232 driver input.

The RS-485 transceiver includes a capacitive isolation barrier that galvanically isolates the bus side from the logic control side, which eliminates ground currents between the bus nodes.

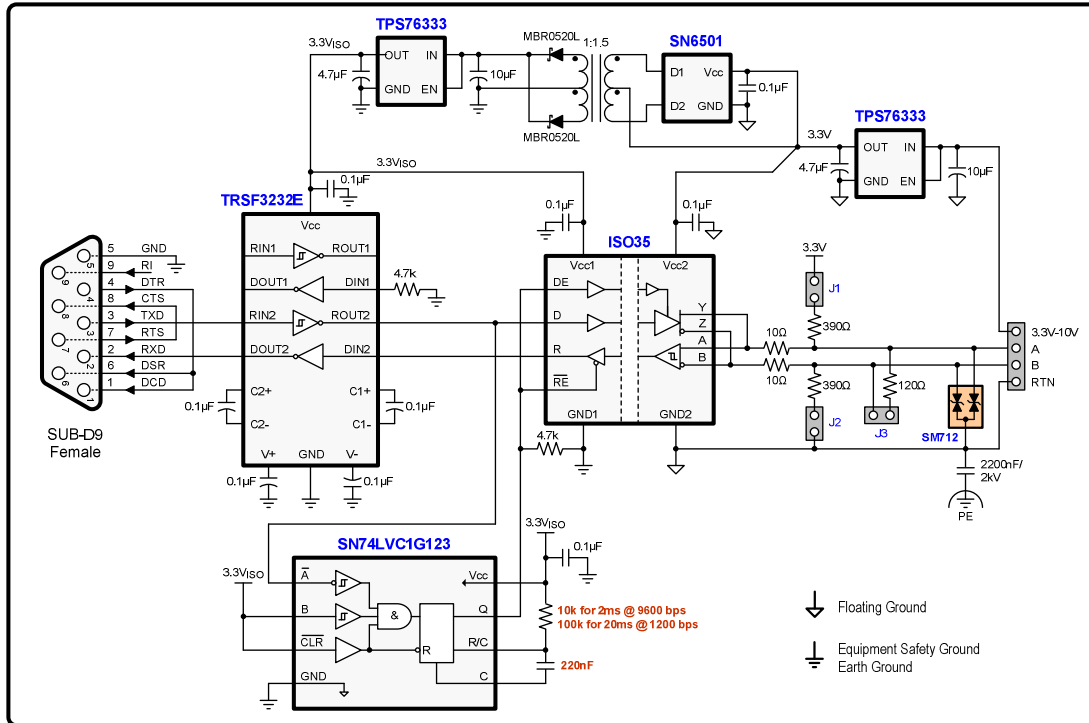

**Figure 2. Isolated RS-232 to RS-485 converter with auto-direction control.**

On the bus side the converter design provides several components to ensure reliable data transmission. Jumpers J1 and J2 activate a failsafe biasing network during bus idling. Via jumper J3 a 120 Ohm termination resistor can be implemented, if this converter is located at a bus end.

A transient suppressor protects the bus transceiver from dangerous transient over-voltages by clamping them to ground potential. In order to divert transient currents to Earth potential, a high-voltage capacitor is required to provide AC-coupling between the floating bus ground and protective Earth (PE). Typically a short single conductor (18 AWG) is used to make the connection to a PE terminal or chassis ground.

Isolating the signal path isolation also requires isolating the power supply. Here the bus supply (3.3V to 10V) is regulated via a low-dropout voltage regulator (LDO). Then it is applied to the transceiver bus supply (Vcc2) and to an isolated DC/DC converter. This converter consists of a transformer driver, an isolation transformer, and a second LDO which supplies the circuits on the logic side.

Older converter designs sometimes use a request-to-send signal (RTS) to switch the RS-485 transceiver from receive into transmit mode. In PC applications, however, the RTS generating interface software runs under Windows® and not in real-time. Thus, if Windows decides to use its processing time for another application, a screen saver or an anti-virus software, RTS might not change the

transceiver back into receive in time, and data sent by another bus node might be lost.

The converter design in **Figure 2** eliminates this possibility by implementing an auto-direction function. The auto-direction detection is accomplished with a monostable flip-flop, whose output is triggered high by the start bit from the 232-receiver output. By default the RS-485 transceiver is in receive mode. When the monostable output goes high, it switches the transceiver into transmit mode.

The time constant of the monostable output is defined by an R-C network with  $C = 220 \text{ nF}$ , and  $R = 10 \text{ k}\Omega$  for a 2 ms high-time at a data rate of 9600 bps, and  $R = 100 \text{ k}\Omega$  for 20 ms at 1200 bps. When the high-time has passed, the monostable output returns to low, thus switching the transceiver back into to receive mode. While the auto-direction function is data rate dependent, it is a reliable method to prevent data loss.

## References

For more information visit: [www.ti.com/rs485-ca](http://www.ti.com/rs485-ca).