

USB HUB

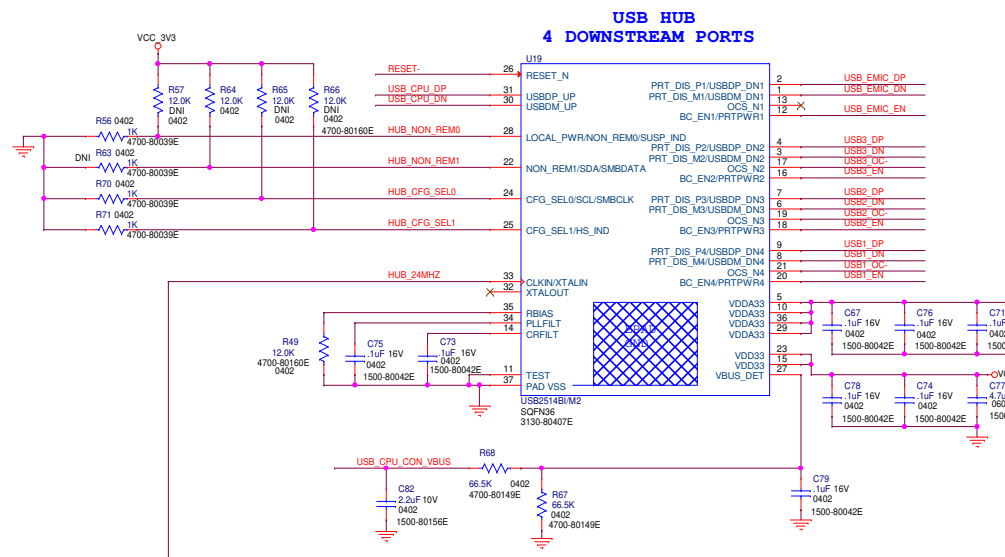

For self-powered applications with a permanently attached host, VBUS_DET pin must be connected to a dedicated host control output, or connected to the 3.3 V domain that powers the host (typically VDD33).

- CFG_SEL[1:0] = <0,0> Default configuration:
- Strap options enabled
 - Self-powered operation enabled
 - Individual power switching
 - Individual over-current sensing
- NON_REM[1:0] = <0,1>: ports 1 is non-removable

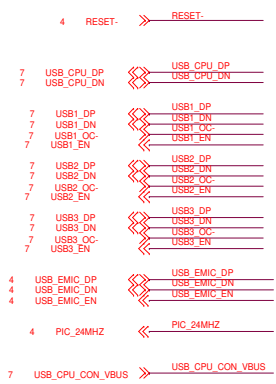
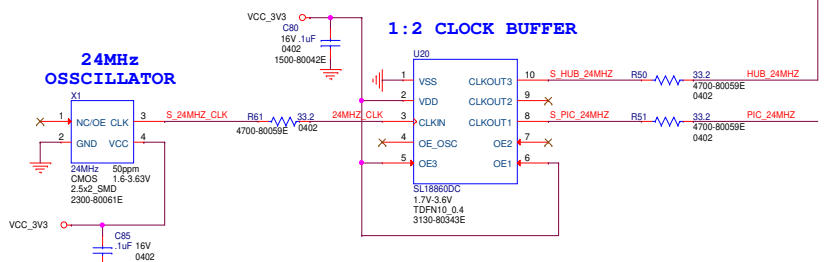

Layout: Place RC at the end of net

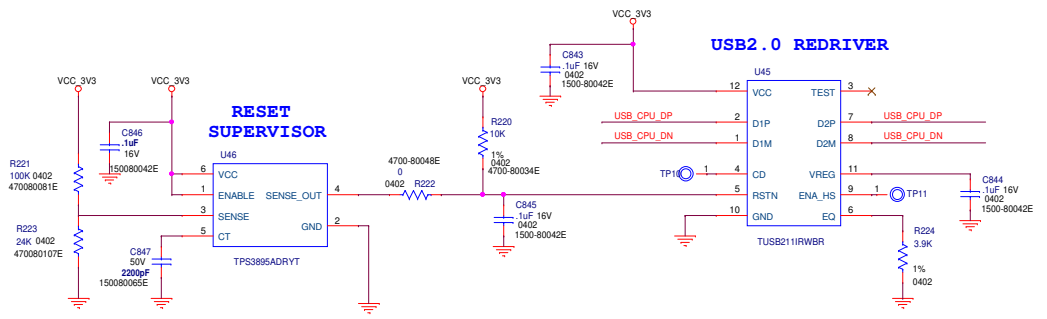

EQ gain setting	R1 [ohms]
Level 0	100 +/- 5%
Level 1	1800 +/- 5%
Level 2	3900 +/- 1%
Level 3 [MIN]	9100 +/- 5%

