

Single End 50ohm impedance

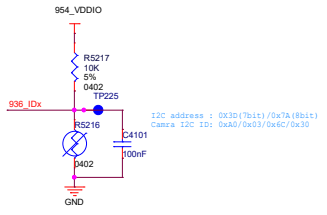

I2C address : 0x3D(7b1c)/0x7A(8b1t)  
Camera I2C ID: 0xA0/0x63/0x6C/0x30

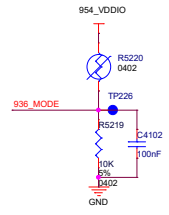

MODE	R(low)	MODE
0 OPEN	10K	936-2 Asynchronous Back channel Mode
1 88.7K	23.2K	RAW12 LP (DS90UB935 TBD)
2 10K	OPEN	RAW10
6 78.7K	91.6K	CSI-2 Synchronous Back channel Mode

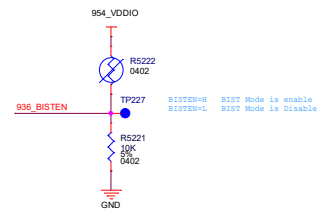

BISTEN=H BIST Mode is enable  
BISTEN=L BIST Mode is Disable

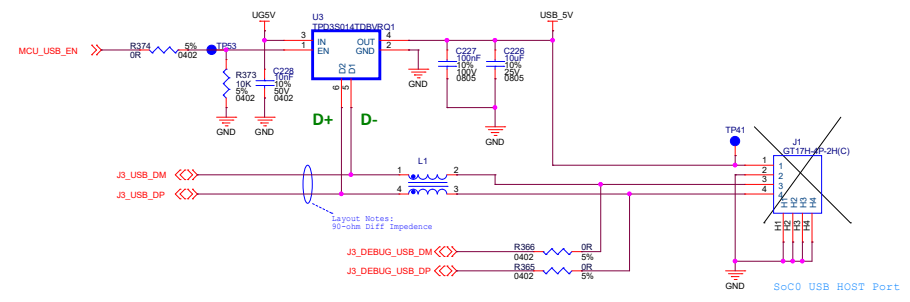





# UG3V3

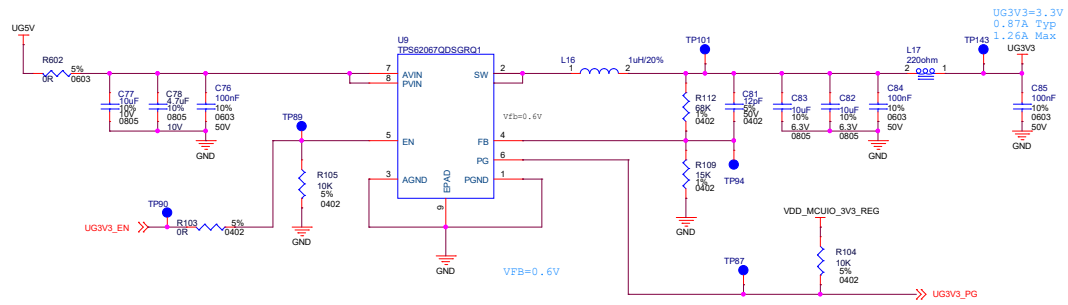

# UG1V1

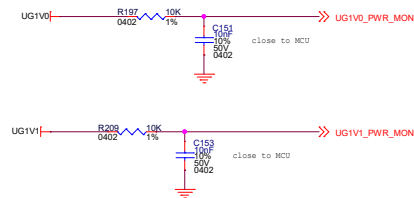
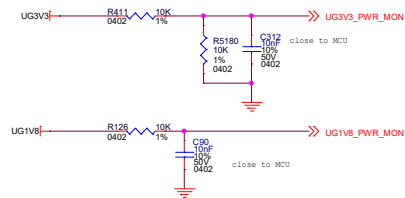
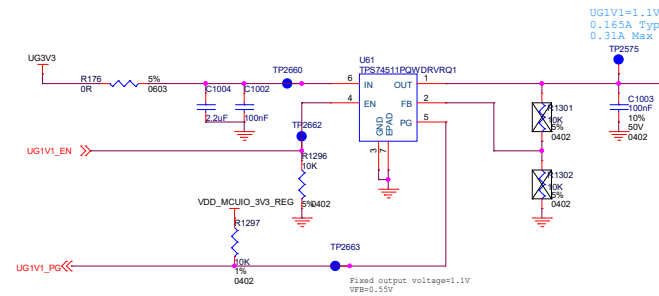

<Variant Name>

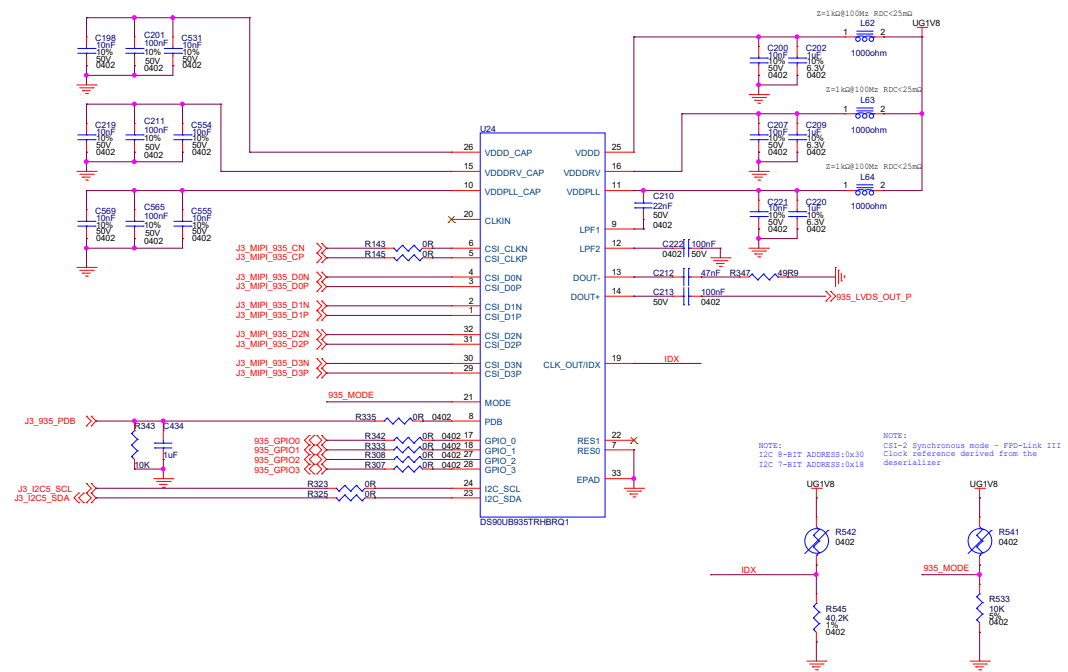





# LEVEL SHFIT

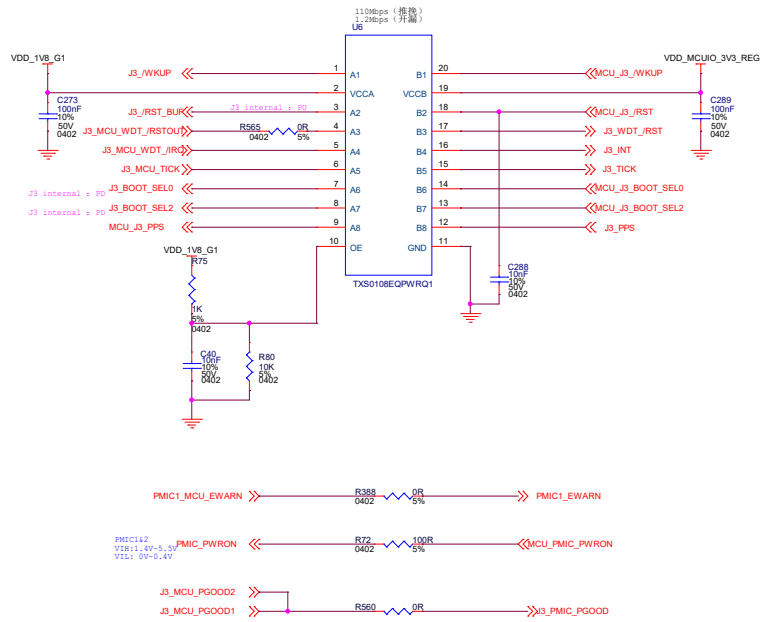

<Variant Name>