

HSD CONN

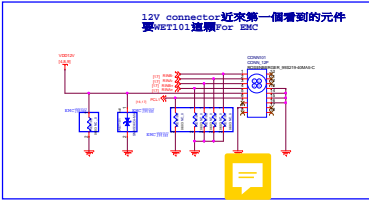

PDB Control

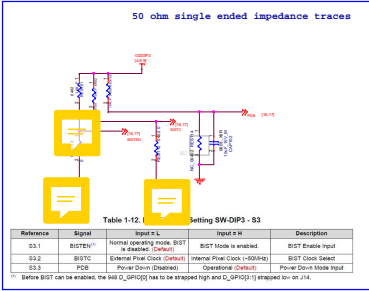

Controller

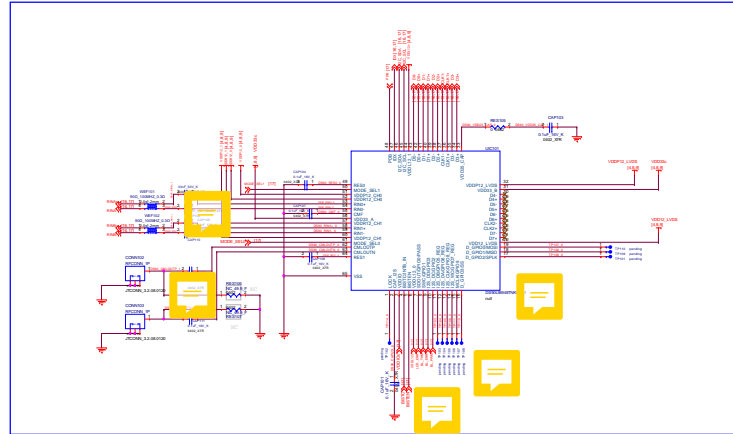

MODE_SEL0/1 Control

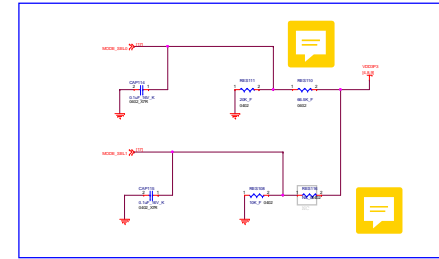

IDX Control

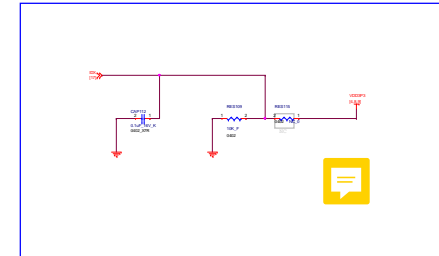

FPC CONN

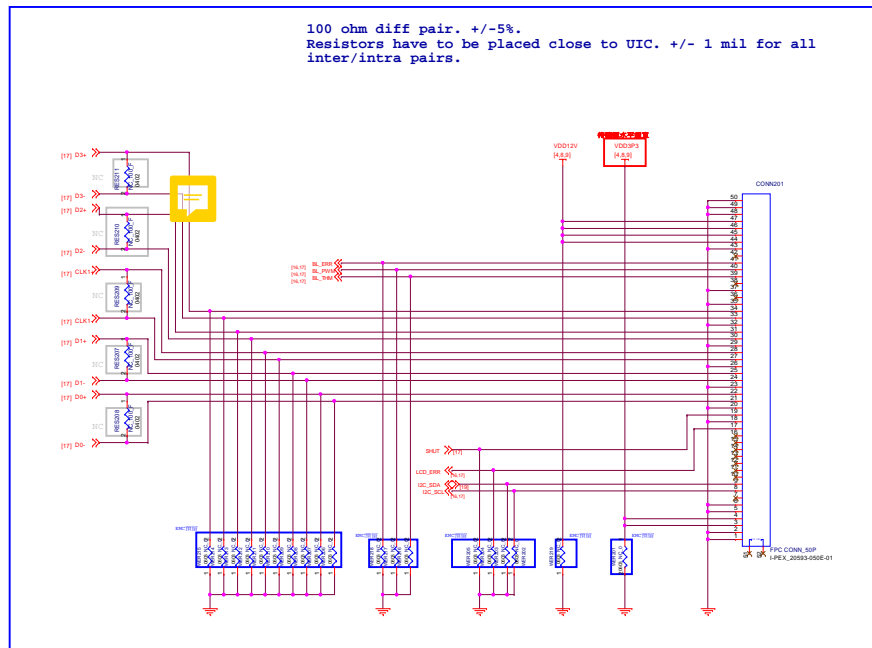

External I2C connection

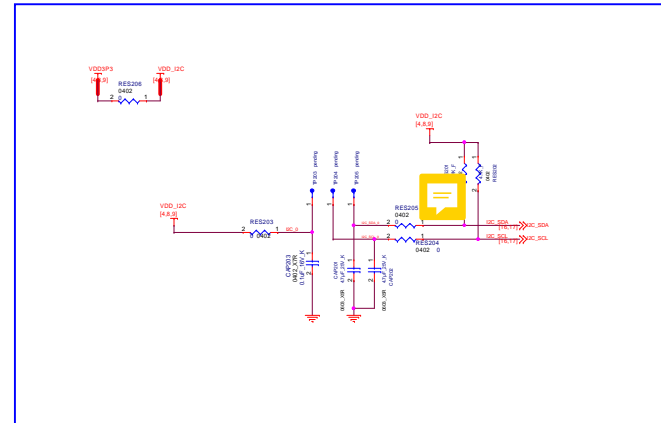

ADC converter to I2C

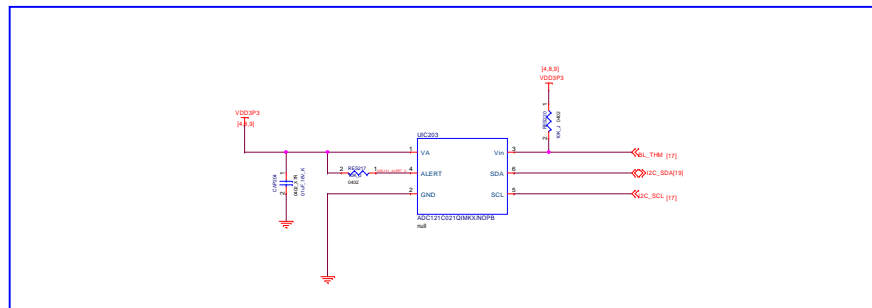

N-MOFET_Confirm PCL1

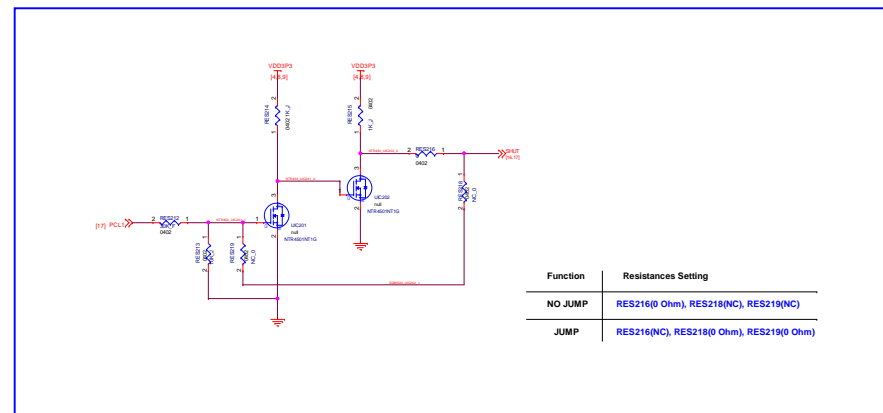

Main power

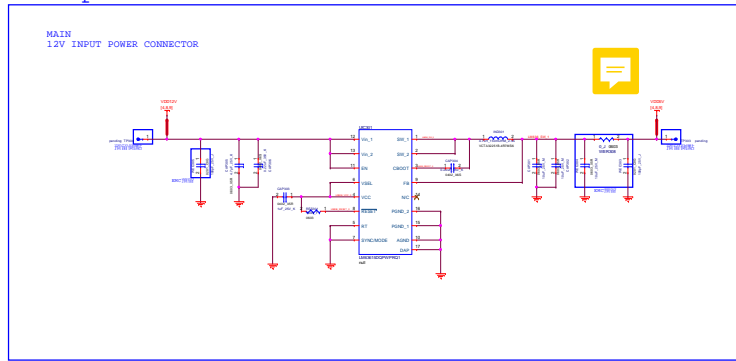

1V2_Power Supply

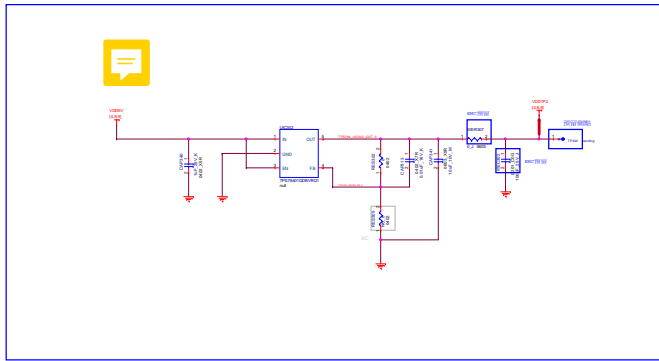

需靠近至UIC101, 並放置在Bottom layer

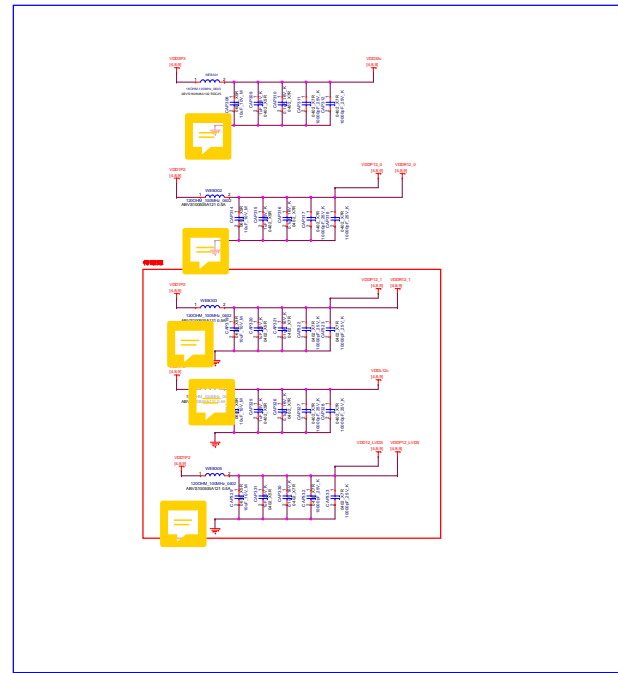

3V3_Power Supply

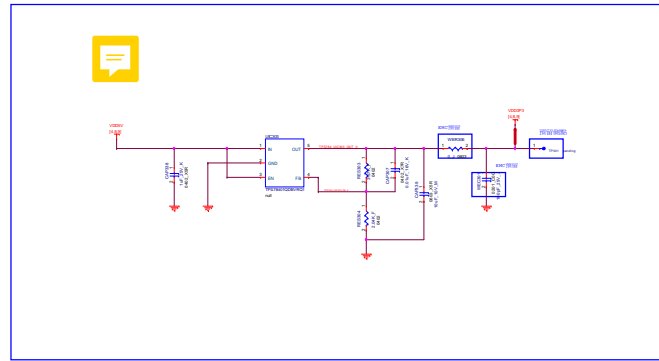

需靠近至UIC101, 並放置在Bottom layer

