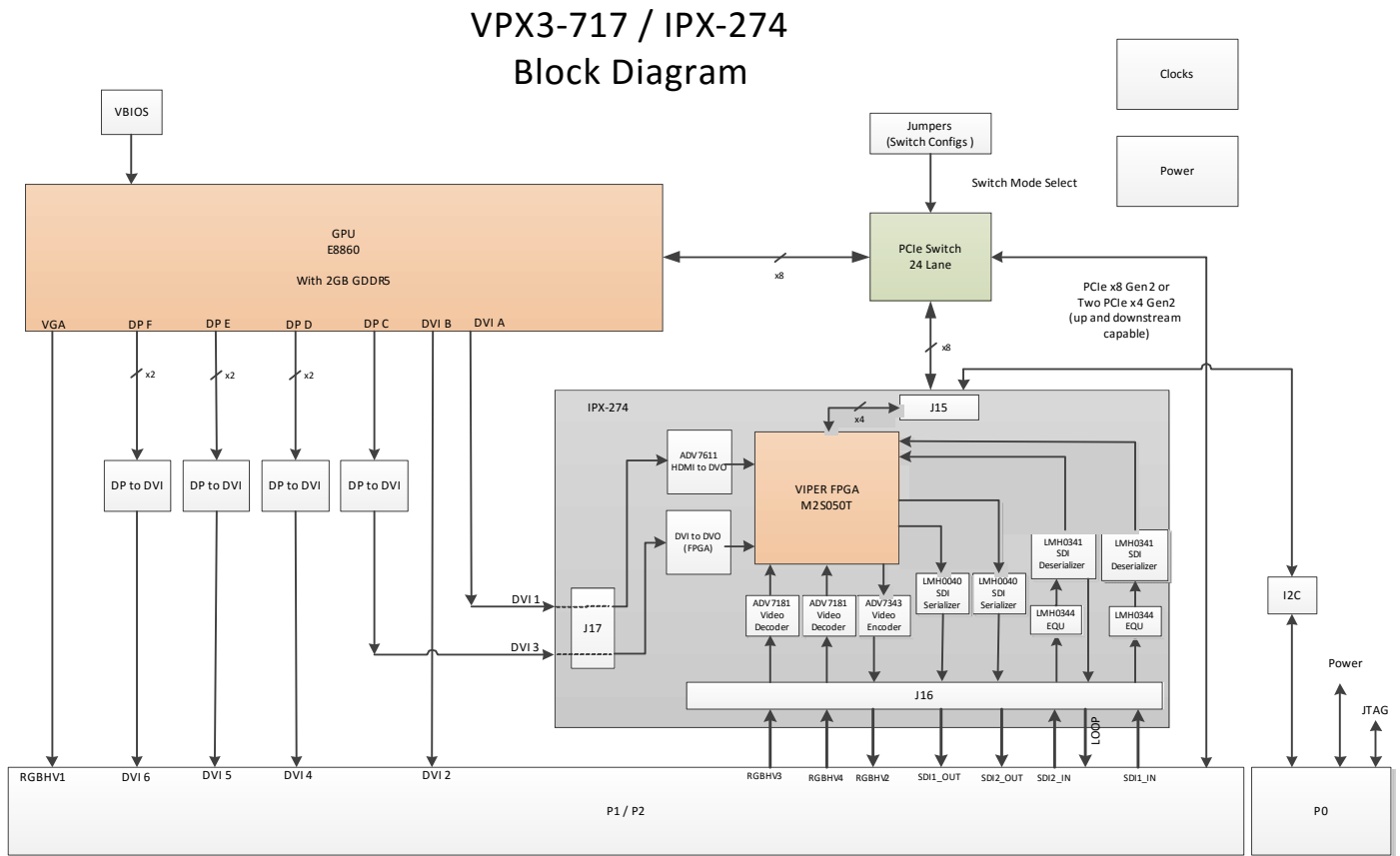

Figure 1.2 shows the architecture of the VPX3-719.

**Figure 1.2: VPX3-719 Functional Block Diagram**



## VIDEO INTERFACES

The VPX3-719 provides the following video interfaces:

- Four DVI outputs supporting up to 1920x1200@60Hz
- One RGBHV output
- One RGBHV/NTSC/PAL/STANAG 3350 Class B/C output
- Two HD-SDI outputs
- One HD-SDI output loop/rebroadcast from HD-SDI input
- Two RGBHV/NTSC/PAL/STANAG 3350 Class B/C capture input
- Two HD-SDI capture input