

TFT POWER

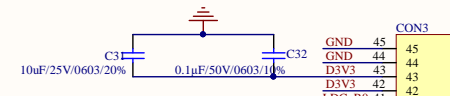

CON3	Pin	Value
GND	45	
GND	44	
D3V3	43	
D3V3	42	
LDC R0	41	
LDC R1	40	
LDC R2	39	
LDC R3	38	
LDC R4	37	
LDC R5	36	
LDC R6	35	
LDC R7	34	
LDC G0	33	
LDC G1	32	
LDC G2	31	
LDC G3	30	
LDC G4	29	
LDC G5	28	
LDC G6	27	
LDC G7	26	
LDC B0	25	
LDC B1	24	
LDC B2	23	
LDC B3	22	
LDC B4	21	
LDC B5	20	
LDC B6	19	
LDC B7	18	
GND	17	
CLK	16	
STB	15	
HS	14	
VS	13	
DE	12	
L1	11	
GND	10	
9	9	
8	8	
7	7	
6	6	
5	5	
4	4	
3	3	
2	2	
1	1	

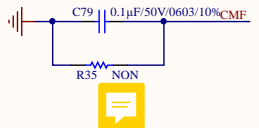
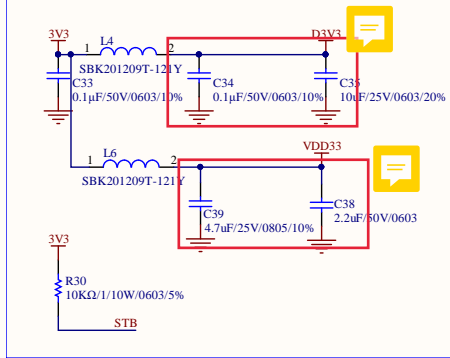
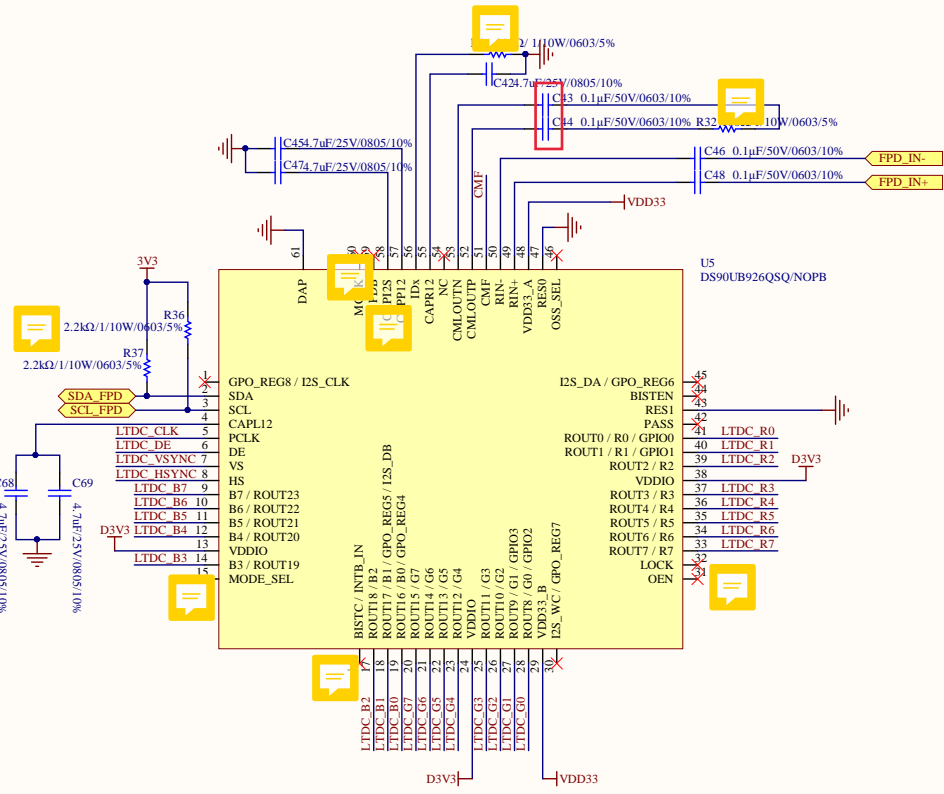
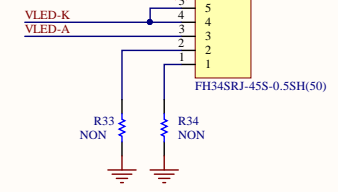
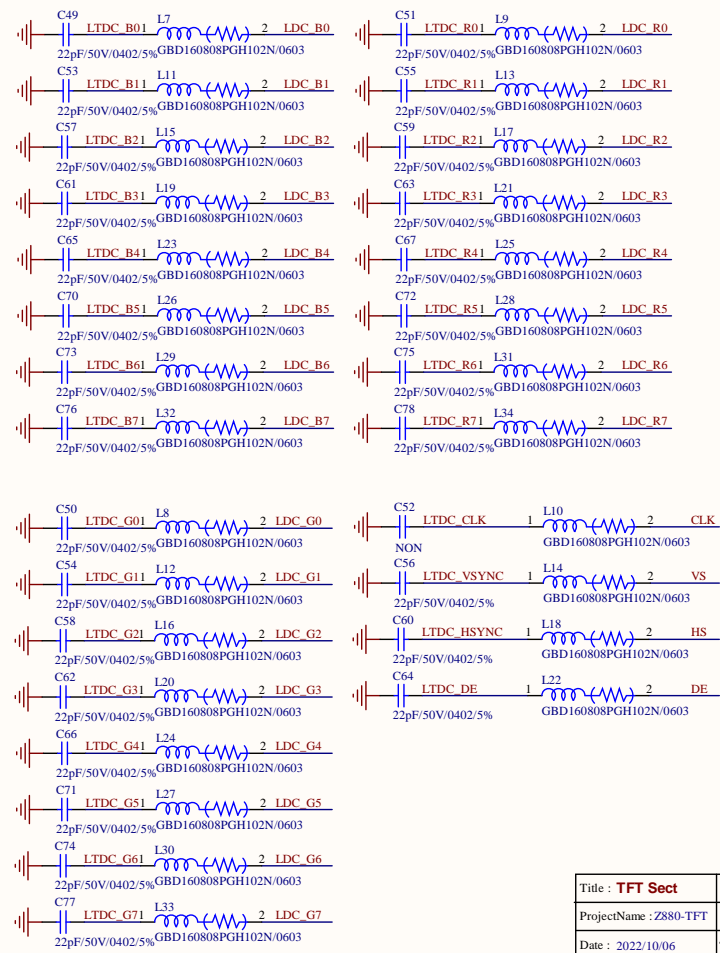

Title : TFT Sect	Circuit version : A0	CHAO LONG MOTOR PARTS CORP
ProjectName : Z880-TFT	PCB version : T0	Sheet : 5 of 5
Date : 2022/10/06	Time : 06:00:46	File : TFT_Sect.SCHDOC
Author :	Check :	Approved :

