

Power-Up Sequencing: VDD18 -0-> VDDIO -0-> VDD11

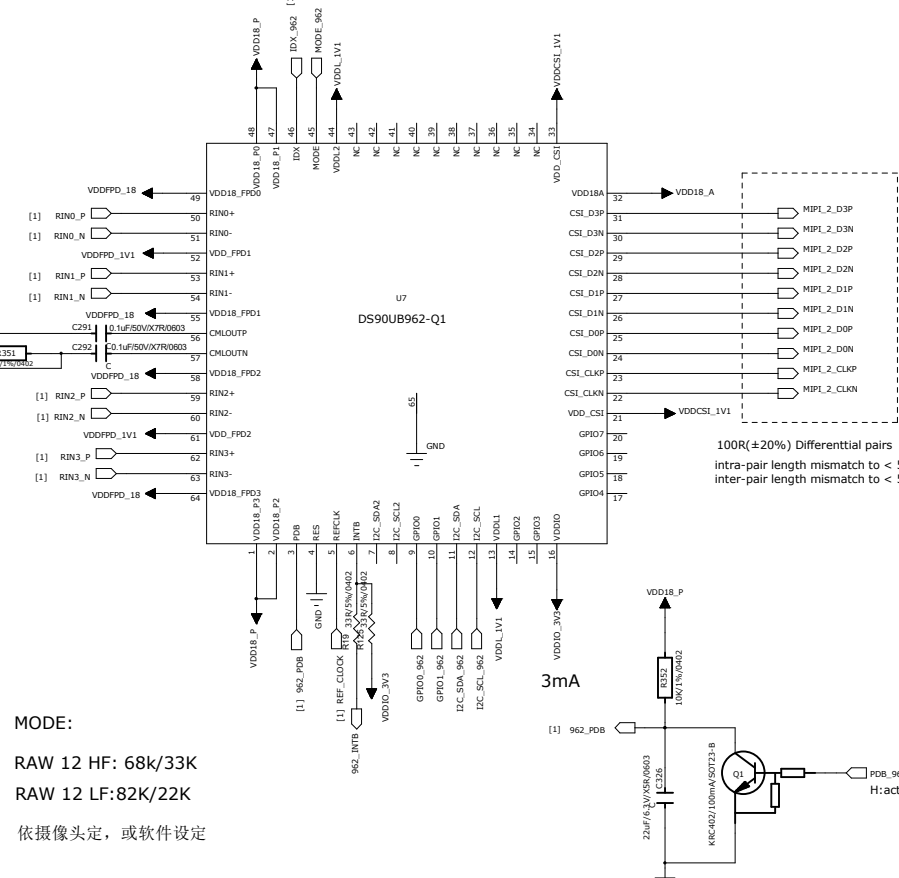
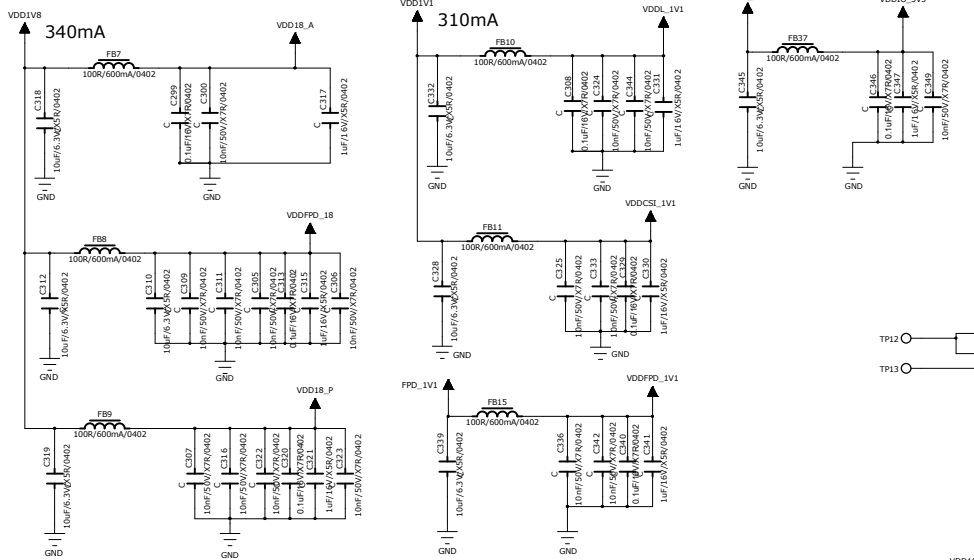

100R(±20%) Differential pairs  
intra-pair length mismatch to < 5 mils.  
inter-pair length mismatch to < 50 mils

MODE:  
RAW 12 HF: 68k/33K  
RAW 12 LF: 82K/22K  
依摄像头定，或软件设定

IDX: 0V  
IIC address:  
7-Bit: 0X30  
8-Bit: 0x60

