

POWER OVER ETHERNET

REVISIONS (ALL SHEETS ARE THE SAME REV)					
ZONE	REV	DESCRIPTION	CHG NO.	APPD	DATE
NA	-	NO CHANGE THIS PAGE	<REV_CD>	S.H.	2021-08-12

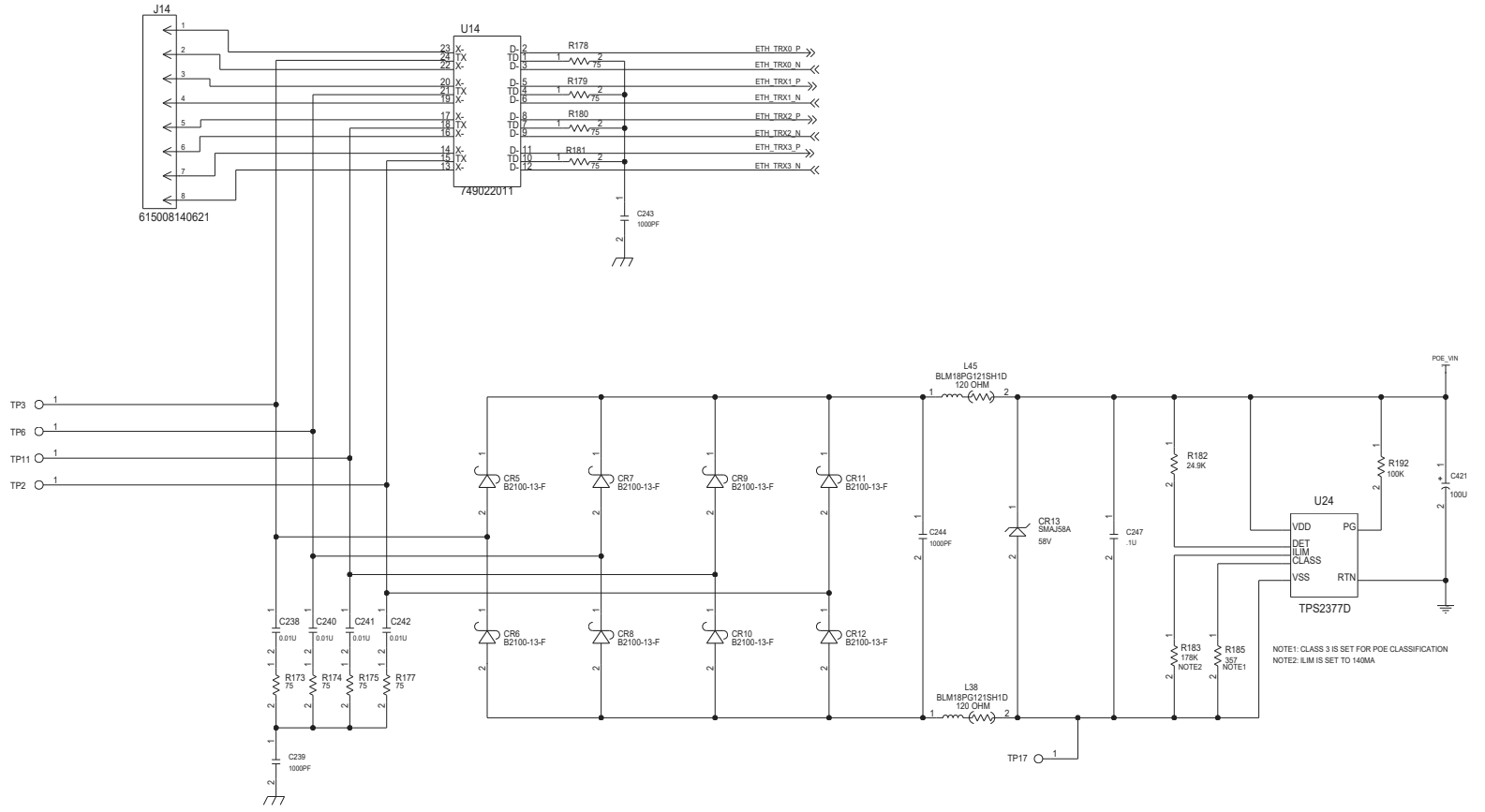

NOTE1: CLASS 3 IS SET FOR POE CLASSIFICATION
 NOTE2: ILM IS SET TO 140MA

Collins Aerospace		U.S. EXPORT CLASSIFICATION: <US_EXPORT_CLASSIFICATION>		
DR SHIVAM.H		CAD MAINTAINED. CHANGES SHALL BE INCORPORATED BY THE DESIGN ACTIVITY		
2021-08-12	SIZE C	CAGE CODE 0	DRAWING NO. <DRAWING_NO>	
CHKD <CHKD_BY>	<CHKD_DATE>	SCALE: NONE	WT.	SHEET 15 OF 26

CADENCE

DRAWING NO. <DRAWING_NO> SH 15

ETHERNET

REVISIONS (ALL SHEETS ARE THE SAME REV)				
ZONE	REV	DESCRIPTION	CHG NO.	APPD DATE
NA	-	NO CHANGE THIS PAGE	<REV_CO>	S.H. 2021-08-12

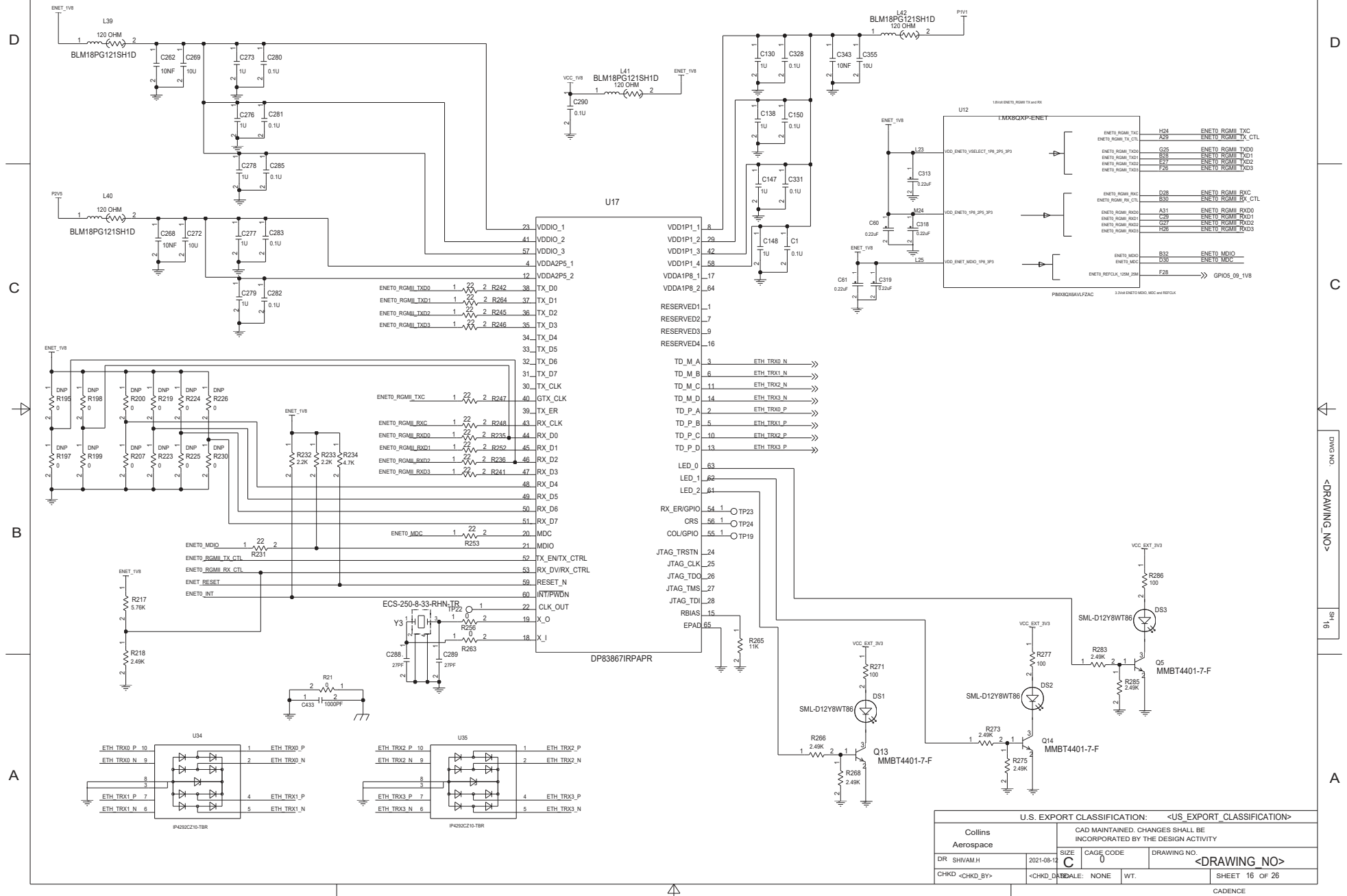

U.S. EXPORT CLASSIFICATION: <US_EXPORT_CLASSIFICATION>				
Collins Aerospace	CAD MAINTAINED. CHANGES SHALL BE INCORPORATED BY THE DESIGN ACTIVITY			
DR SHIVAMH	2021-08-12	SIZE C	CAGE CODE 0	DRAWING NO. <DRAWING_NO>
CHKD <CHKD_BY>	<CHKD_DATE>	SCALE: NONE	WT.	SHEET 16 OF 26

DRAWING NO. <DRAWING_NO>

SHEET 16 OF 26

CADENCE