

A

B

C

D

A

B

C

D

Place bypass capacitors as close to the supply pins as possible

Place bypass capacitors as close to the supply pins as possible

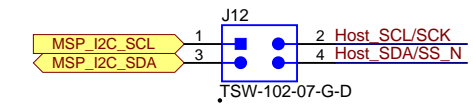
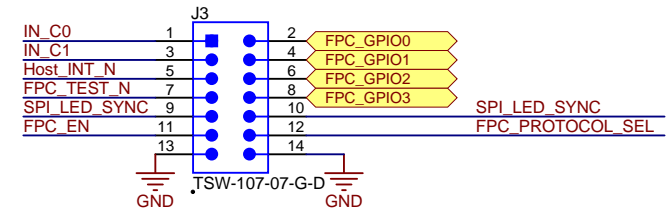
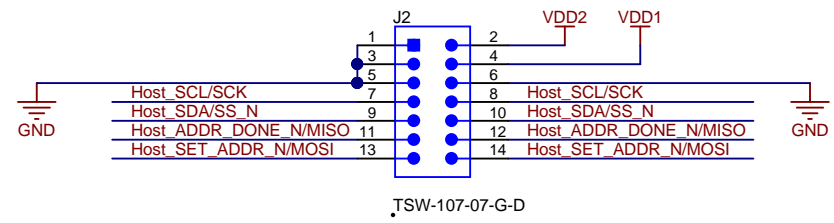
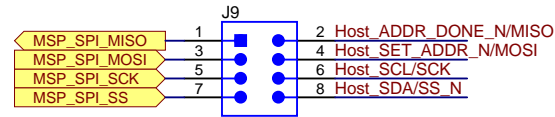
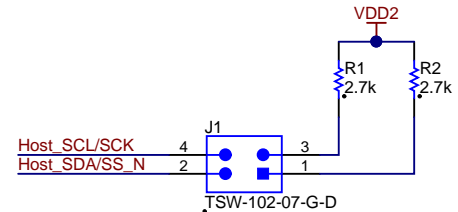
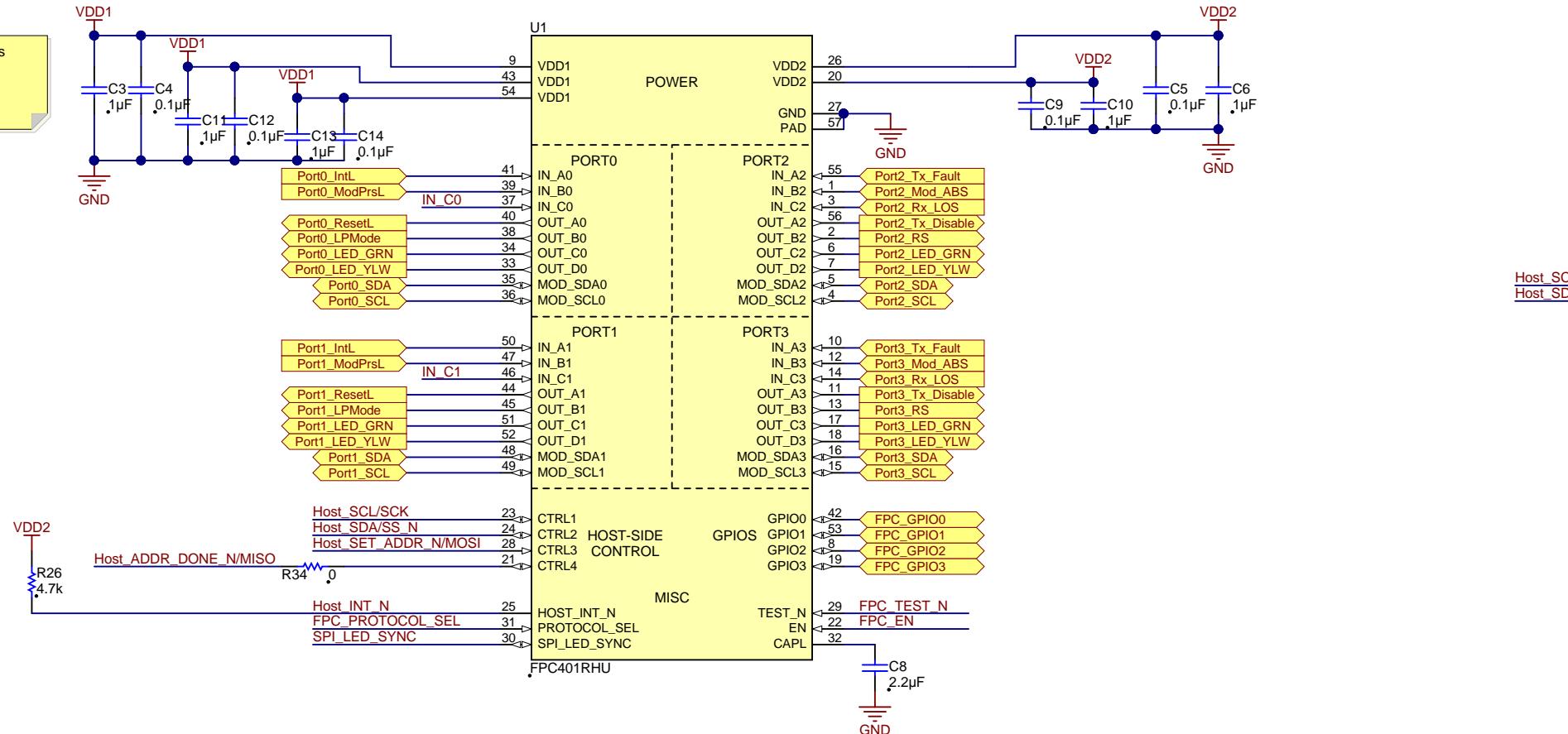

Texas Instruments and/or its licensors do not warrant the accuracy or completeness of this specification or any information contained therein. Texas Instruments and/or its licensors do not warrant that this design will meet the specifications, will be suitable for your application or fit for any particular purpose, or will operate in an implementation. Texas Instruments and/or its licensors do not warrant that the design is production worthy. You should completely validate and test your design implementation to confirm the system functionality for your application.

Orderable: PDC401EVM	Designed for: Public Release	Mod. Date: 11/30/2016
TID #: TID	Project Title: FPC401EVM	
Number: SV601279	Rev: B	Sheet Title:
SVN Rev: Version control disabled	Assembly Variant: 001	Sheet: 1 of 4
Drawn By: Gui Borba	File: SV601279B.SchDoc	Size: B
Engineer: Gui Borba	Contact: http://www.ti.com/support	



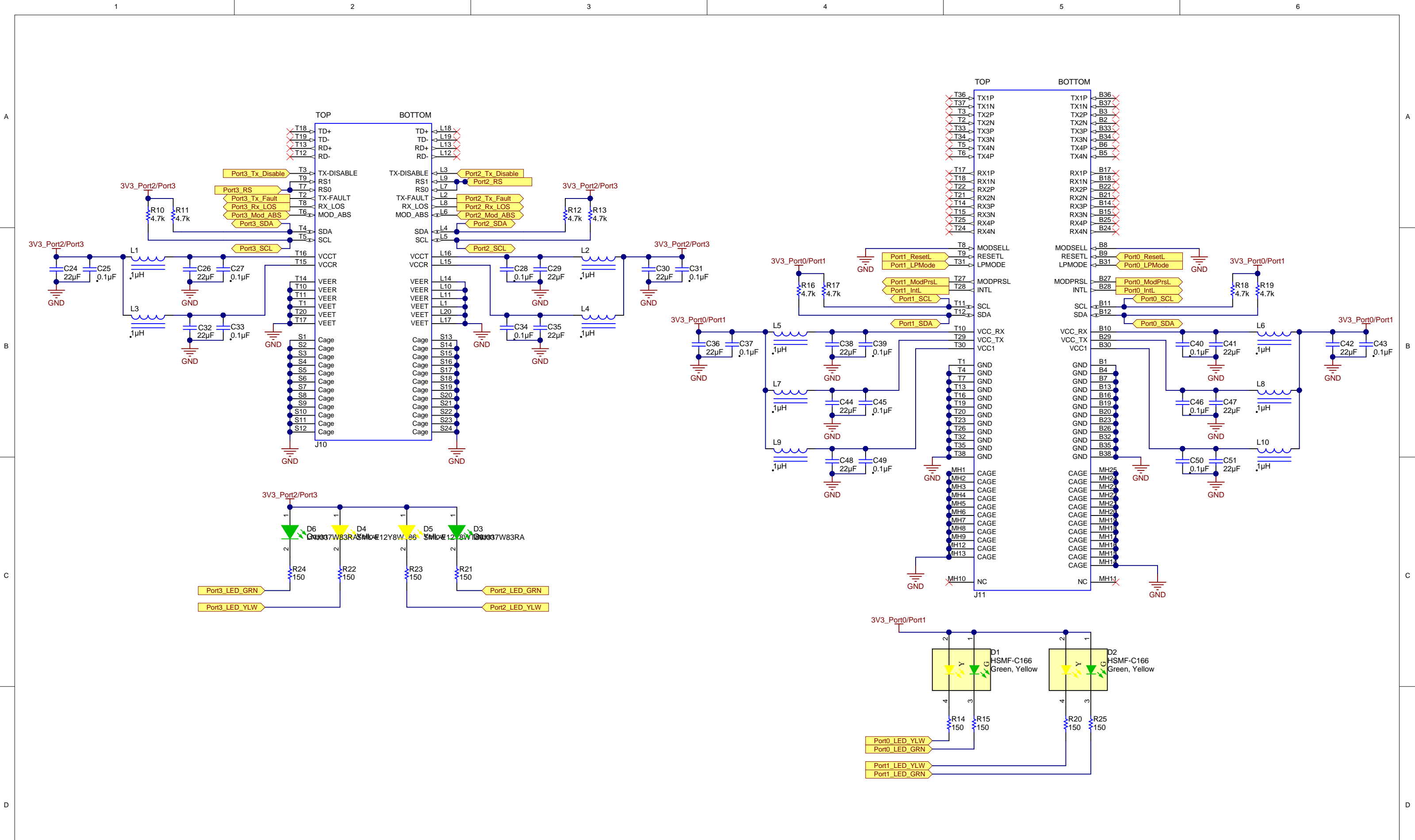

Texas Instruments and/or its licensors do not warrant the accuracy or completeness of this specification or any information contained therein. Texas Instruments and/or its licensors do not warrant that this design will meet the specifications, will be suitable for your application or fit for any particular purpose, or will operate in an implementation. Texas Instruments and/or its licensors do not warrant that the design is production worthy. You should completely validate and test your design implementation to confirm the system functionality for your application.

Orderable: PDC401EVM	Designed for: Public Release	Mod. Date: 11/30/2016
TID #: TID	Project Title: FPC401EVM	
Number: SV601279	Rev: B	Sheet: 2 of 4
SVN Rev: Version control disabled	Assembly Variant: 001	Size: B
Drawn By: Gui Borba	File: SV601279B_Connectors.SchDoc	Contact: http://www.ti.com/support
Engineer: Gui Borba		© Texas Instruments 2016



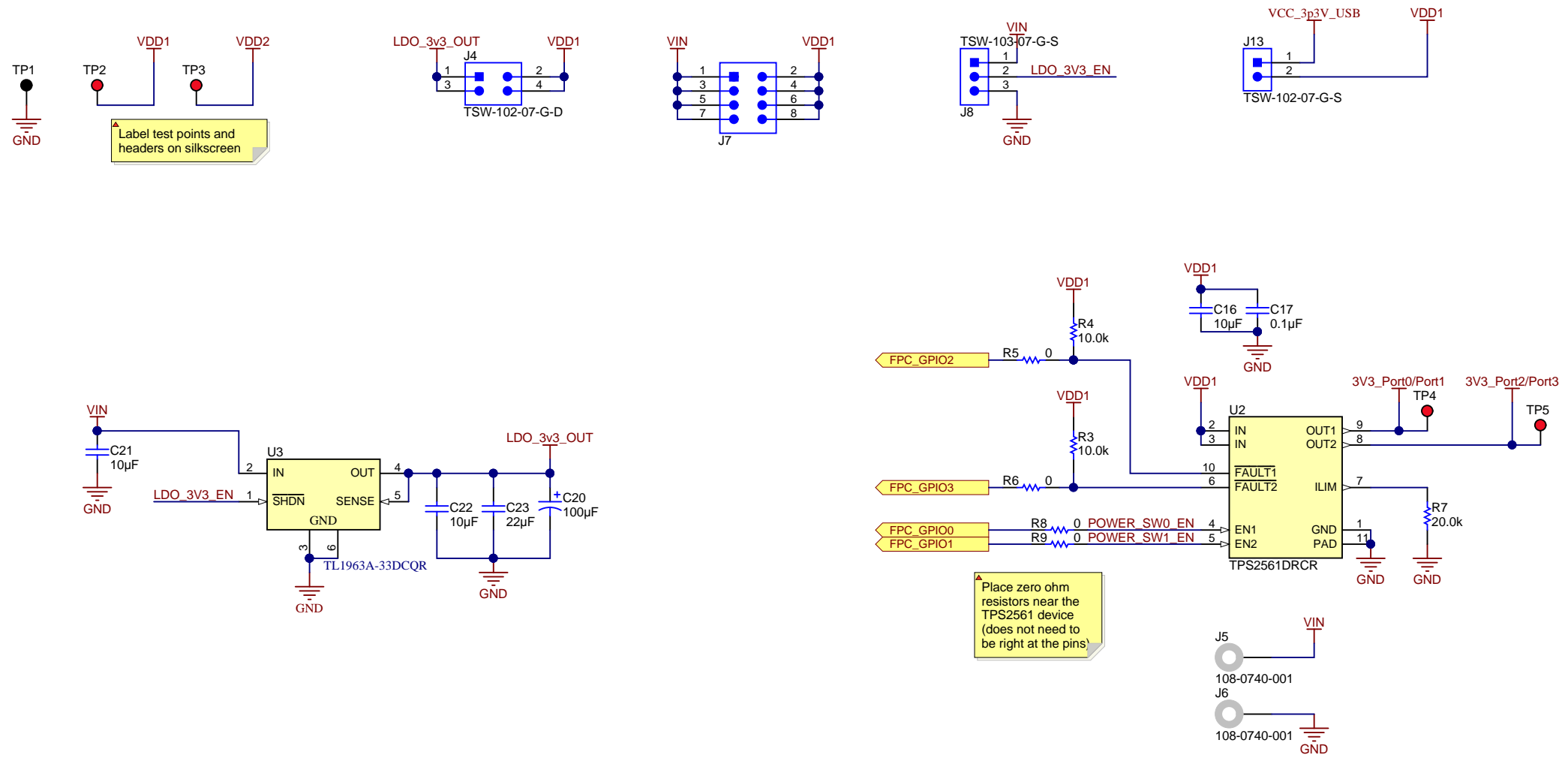

Texas Instruments and/or its licensors do not warrant the accuracy or completeness of this specification or any information contained therein. Texas Instruments and/or its licensors do not warrant that this design will meet the specifications, will be suitable for your application or fit for any particular purpose, or will operate in an implementation. Texas Instruments and/or its licensors do not warrant that the design is production worthy. You should completely validate and test your design implementation to confirm the system functionality for your application.

Orderable: PDC401EVM	Designed for: Public Release	Mod. Date: 11/30/2016
TID #: TID	Project Title: FPC401EVM	
Number: SV601279	Rev: B	Sheet Title:
SVN Rev: Version control disabled	Assembly Variant: 001	Sheet: 3 of 4
Drawn By: Gui Borba	File: SV601279B_Power.SchDoc	Size: B
Engineer: Gui Borba	Contact: http://www.ti.com/support	



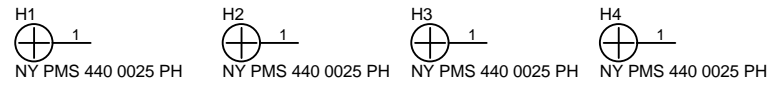

PCB Number: SV601279
PCB Rev: B

PCB LOGO
Logo1 PCB LOGO
Logo2 PCB LOGO

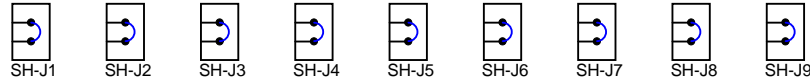

ZZ5
Assembly Note
Place shunt SH-J1 between pins 1 and 2 of connector J8

ZZ6
Assembly Note
Place shunt SH-J2 between pins 1 and 2 of connector J4

ZZ7
Assembly Note
Place shunt SH-J3 between pins 3 and 4 of connector J4

ZZ8
Assembly Note
Place shunt SH-J4 between pins 12 and 14 of connector J3

ZZ9
Assembly Note
Place shunt SH-J5 between pins 1 and 2 of connector J9

ZZ10
Assembly Note
Place shunt SH-J6 between pins 3 and 4 of connector J9

ZZ11
Assembly Note
Place shunt SH-J7 between pins 5 and 6 of connector J9

ZZ12
Assembly Note
Place shunt SH-J8 between pins 7 and 8 of connector J9

ZZ13
Assembly Note
Place shunt SH-J9 between pins 2 and 4 of connector J2

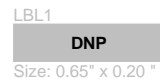

ZZ1
Assembly Note
These assemblies are ESD sensitive, ESD precautions shall be observed.

ZZ2
Assembly Note
These assemblies must be clean and free from flux and all contaminants. Use of no clean flux is not acceptable.

ZZ3
Assembly Note
These assemblies must comply with workmanship standards IPC-A-610 Class 2, unless otherwise specified

ZZ4
Assembly Note
Vendor stamps or labels must not cover any silkscreen or components.

Orderable: PDC401EVM	Designed for: Public Release	Mod. Date: 11/30/2016	 http://www.ti.com © Texas Instruments 2016
TID #: TID	Project Title: FPC401EVM		
Number: SV601279	Rev: B	Sheet Title:	
SVN Rev: Version control disabled	Assembly Variant: 001	Sheet: 4 of 4	
Drawn By: Gui Borba	File: SV601279B_Hardware.SchDoc	Size: B	
Engineer: Gui Borba	Contact: http://www.ti.com/support		

Texas Instruments and/or its licensors do not warrant the accuracy or completeness of this specification or any information contained therein. Texas Instruments and/or its licensors do not warrant that this design will meet the specifications, will be suitable for your application or fit for any particular purpose, or will operate in an implementation. Texas Instruments and/or its licensors do not warrant that the design is production worthy. You should completely validate and test your design implementation to confirm the system functionality for your application.

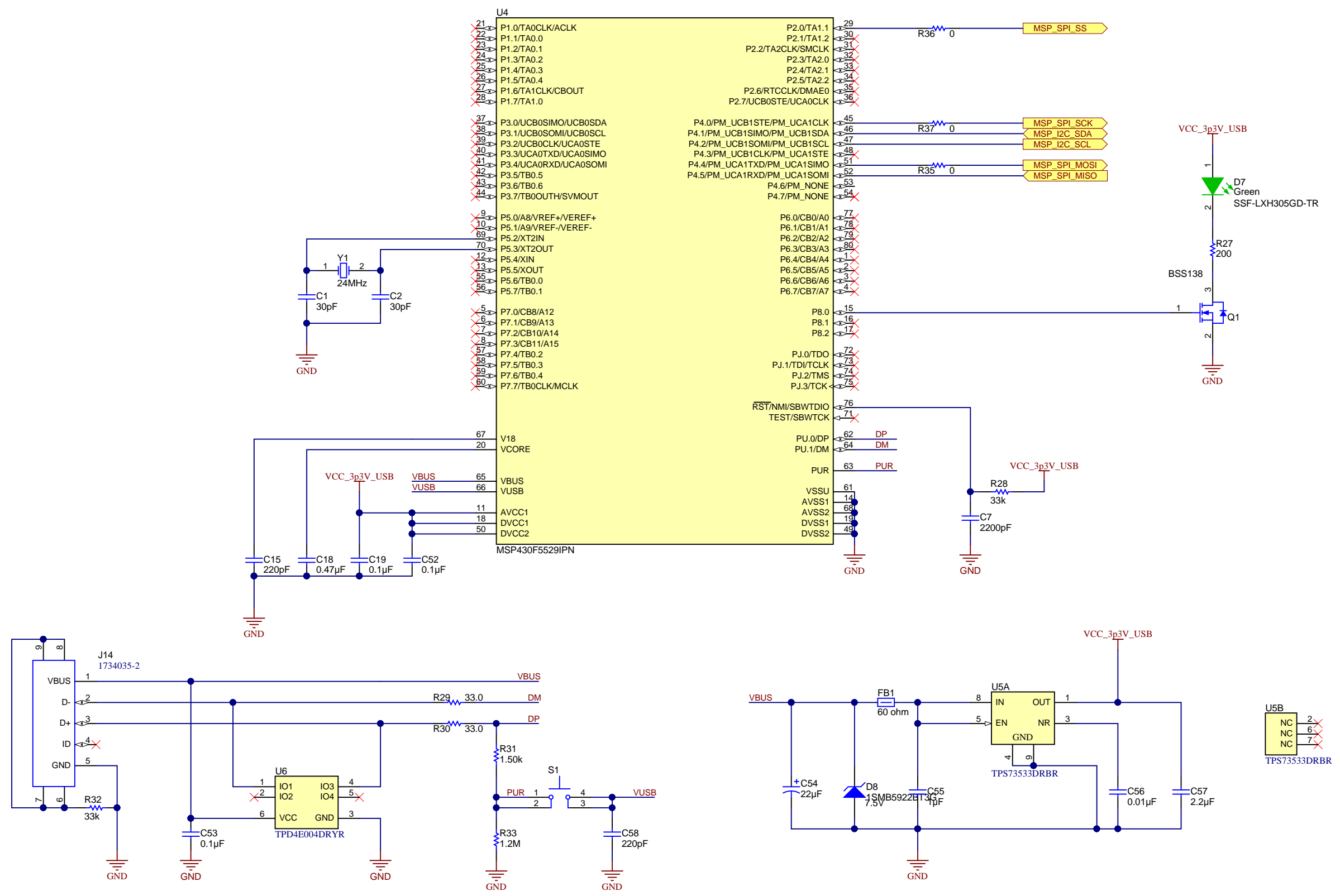

Texas Instruments and/or its licensors do not warrant the accuracy or completeness of this specification or any information contained therein. Texas Instruments and/or its licensors do not warrant that this design will meet the specifications, will be suitable for your application or fit for any particular purpose, or will operate in an implementation. Texas Instruments and/or its licensors do not warrant that the design is production worthy. You should completely validate and test your design implementation to confirm the system functionality for your application.

Orderable: PDC401EVM	Designed for: Public Release	Mod. Date: 11/30/2016
TID #: TID	Project Title: FPC401EVM	
Number: SV601279	Rev: B	Sheet Title:
SVN Rev: Version control disabled	Assembly Variant: 001	Sheet: 6 of 8
Drawn By:	File: SV601279B_USB2ANY.SchDoc	Size: B
Engineer: Gui Borba	Contact: http://www.ti.com/support	

