



# DATASHEET

7/21/2011

Fema Part Number

GM800600T-104-TTX2NLW	
Description	Full Color TFT LCD
	800 x 600 Resolution
	10.4" Diagonal
	LED Backlight (400 nits typical)
	Touch Panel Option Available

Fema Electronics Corporation:

17815 Newhope Street, Suite G, Fountain Valley, CA 92708 Tel: 714-825-0140

Please visit our website [www.femacorp.com](http://www.femacorp.com) or email us at [tft@femacorp.com](mailto:tft@femacorp.com)

---

## 1 General Specifications

Feature		Spec
<b>Display Spec.</b>	Size	10.4 inch
	Resolution	800(RGB) x 600
	Interface	LVDS 6 bits
	Color Depth	262K
	Technology Type	a-Si
	Pixel Pitch (mm)	0.264x0.264
	Pixel Configuration	R.G.B. Vertical Stripe
	Display Mode	TM with Normally White
	Surface Treatment(Up Polarizer)	Anti-Glare(3H)
	Viewing Direction	12 o'clock
	Gray Scale Inversion Direction	6 o'clock
<b>Mechanical Characteristics</b>	LCM (W x H x D) (mm)	236.00x176.90x5.60
	Active Area(mm)	211.20x158.40
	With /Without TSP	Without TSP
	Weight (g)	288

Note 1: Viewing direction for best image quality is different from TFT definition, there is a 180 degree shift.

Note 2 : Requirements on Environmental Protection: RoHS

Note 3 : LCM weight tolerance : +/- 5%

---

---

## 2 Input/Output Terminals

### 2.1 TFT LCD Panel

Matching connector of Hirose DF19K-20P-1H (56)

No	Symbol	I/O	Description	Comment
1	VDD	P	Power Supply	
2	VDD	P	Power Supply	
3	GND	P	Ground	
4	GND	P	Ground	
5	IN0-	I	LVDS receiver negative signal channel 0	
6	IN0+	I	LVDS receiver positive signal channel 0	
7	GND	P	Ground	
8	IN1-	I	LVDS receiver negative signal channel 1	
9	IN1+	I	LVDS receiver positive signal channel 1	
10	GND	P	Ground	
11	IN2-	I	LVDS receiver negative signal channel 2	
12	IN2+	I	LVDS receiver positive signal channel 2	
13	GND	P	Ground	
14	CLK-	I	LVDS receiver negative signal clock	
15	CLK+	I	LVDS receiver positive signal clock	
16	GND	P	Ground	
17	NC	-	No connection	
18	NC	-	No connection	
19	GND	P	Ground	
20	GND	P	Ground	

Note: I/O definition:

I----Input O---Output P----Power/Ground

### 2.2 CN2 (LED connector)

No	Symbol	I/O	Description	Wire Color
1	VL1	P	LED power supply(high voltage)	Red
2	VL2	P	LED power supply(GND)	White

---

### 3 Absolute Maximum Ratings

#### 3.1 Driving TFT LCD Panel

GND=0V, Ta = 25°C

Item	Symbol	Min	Max	Unit	Remark
Power Voltage	VDD	-0.3	5.0	V	
Input voltage	V <sub>IN</sub>	-0.3	5.0	V	Note1
Operating Temperature	T <sub>OPR</sub>	-20	70	°C	
Storage Temperature	T <sub>STG</sub>	-30	80	°C	

Note1: V<sub>IN</sub> represent IN0±, IN1±, IN2±, CLK±

### 4 Electrical Characteristics

#### 4.1 Driving TFT LCD Panel

GND=0V, Ta=25°C

Item	Symbol	Min	Typ	Max	Unit	Remark
LVDS Differential input high threshold	V <sub>TH</sub>	-	-	+100	mV	V <sub>CMLVDS</sub> =1.2V
LVDS Differential input low threshold	V <sub>TL</sub>	-100	-	-	mV	V <sub>CMLVDS</sub> =1.2V
Differential input voltage	V <sub>ID</sub>	0.1	-	0.6	V	
LVDS input common mode voltage	V <sub>CMLVDS</sub>	V <sub>ID</sub>  /2	-	1.4-( V <sub>ID</sub>  /2)	V	
Input current	I <sub>IN</sub>	-10	-	10	μA	
Supply Voltage	VDD	3.0	3.3	3.6	V	
Common Electrode Driving Signal	VCOM	-	4.36	-	V	Note1
Sync Frequency	FVD	-	60	70	Hz	
VDD Power Consumption	I <sub>DD</sub>	-	260	380	mA	Note2

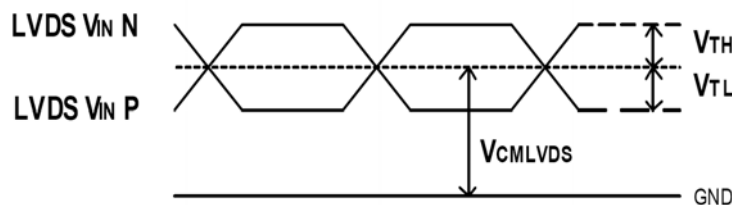

Figure 4.1.1 LVDS DC timing diagram

Note1: The value may be different for different LCM.

Note2: To test the current dissipation, using the “color bar” testing pattern shown as below:

1. White
2. Yellow
3. Cyan
4. Green
5. Magenta
6. Red
7. Blue
8. Black

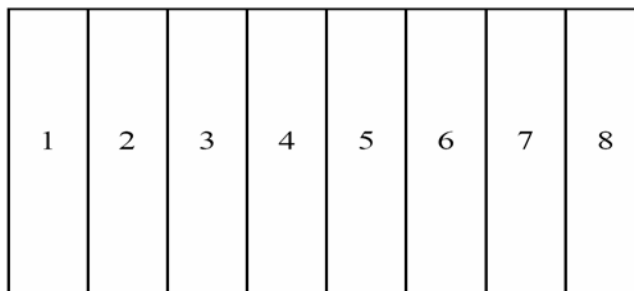

Figure 4.1.2 Current dissipation testing pattern

## 4.2 Driving Backlight

Ta=25°C

Item	Symbol	Min	Typ	Max	Unit	Remark
Forward Current	$I_F$	-	120.0	-	mA	Note 1
Forward Current Voltage	$V_F$	17.7		20.7	V	Note 1
Backlight Power Consumption	WBL	-	2304	2484	mW	Note 1
Operating Life Time	--	10000	(20000)	--	hrs	Note 2

Note 1: The figure below shows the connection of backlight LED.

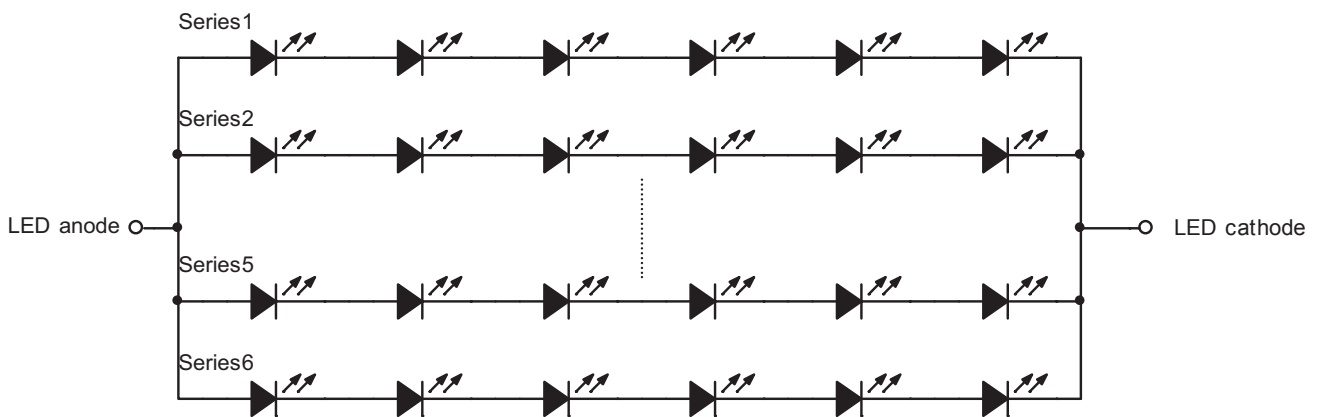

Figure 4.2 LED connection of backlight

Note 2:  $I_F$  is defined for one channel LED.

Optical performance should be evaluated at Ta=25°C only.

If LED is driven by high current, high ambient temperature & humidity condition.

The life time of LED will be reduced.

Operating life means brightness goes down to 50% initial brightness.

Typical operating life time is estimated data.

Note 3: One LED:  $I_F = 20\text{mA}$ .

### 4.3 Block Diagram

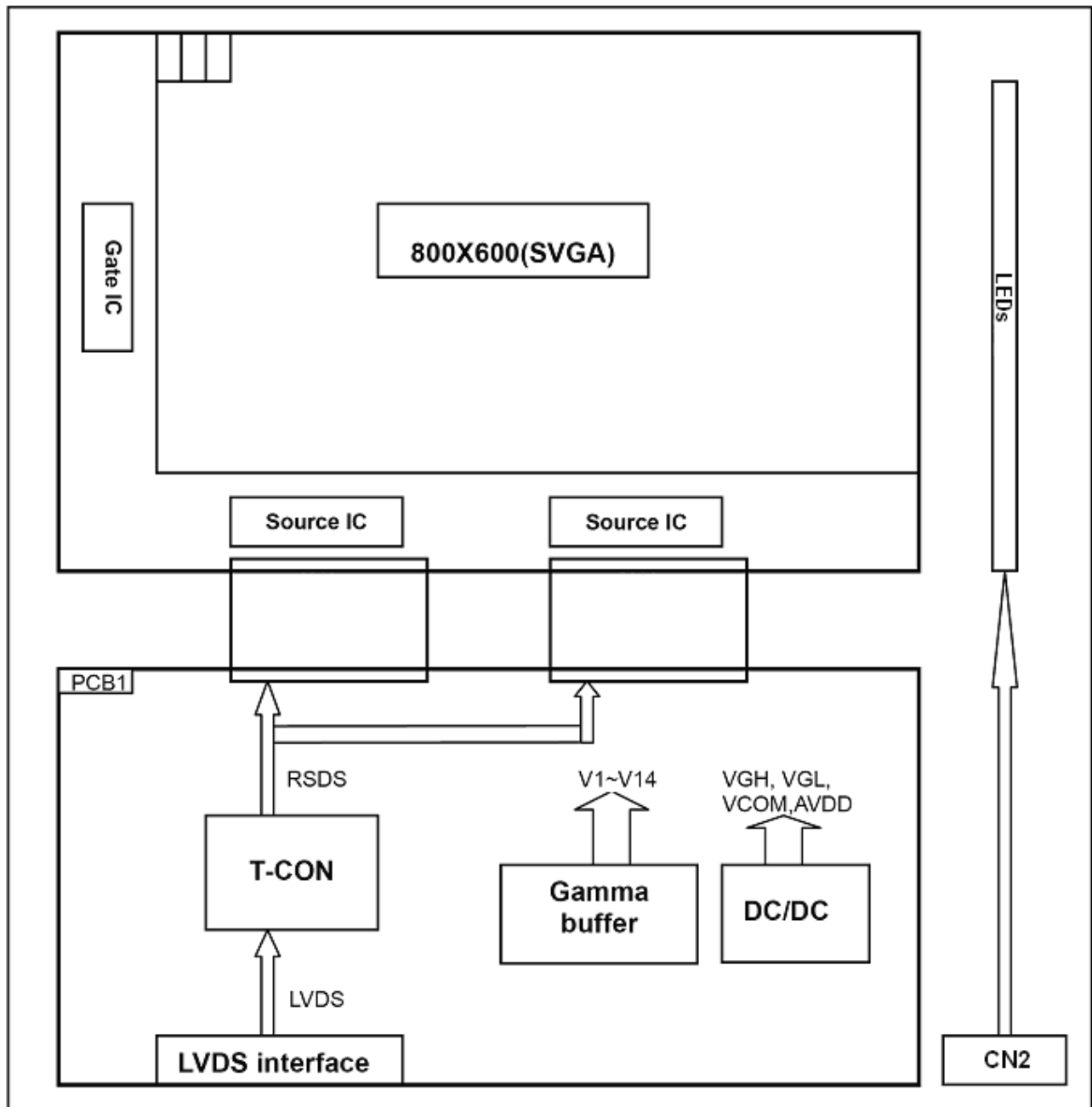

## 5 Timing Chart

### 5.1 Timing Parameter

Item	Symbol	Min	Typ	Max	Unit	Condition
Clock period	tLVCP	20.0	25	31.25	ns	
Clock high time	tLVCH	-	14.29	-	ns	
Clock low time	tLVCL	-	10.71	-	ns	
PLL wake-up time	tLVPLL	-	-	1	ms	
Input skew margin	tLVSKM	400	-	-	ps	f=85MHz

Table 5.1 timing parameter

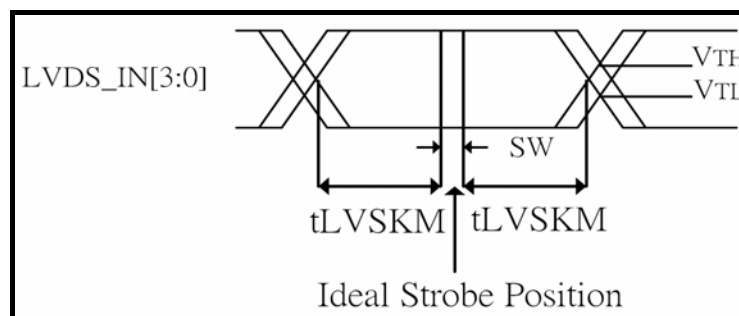
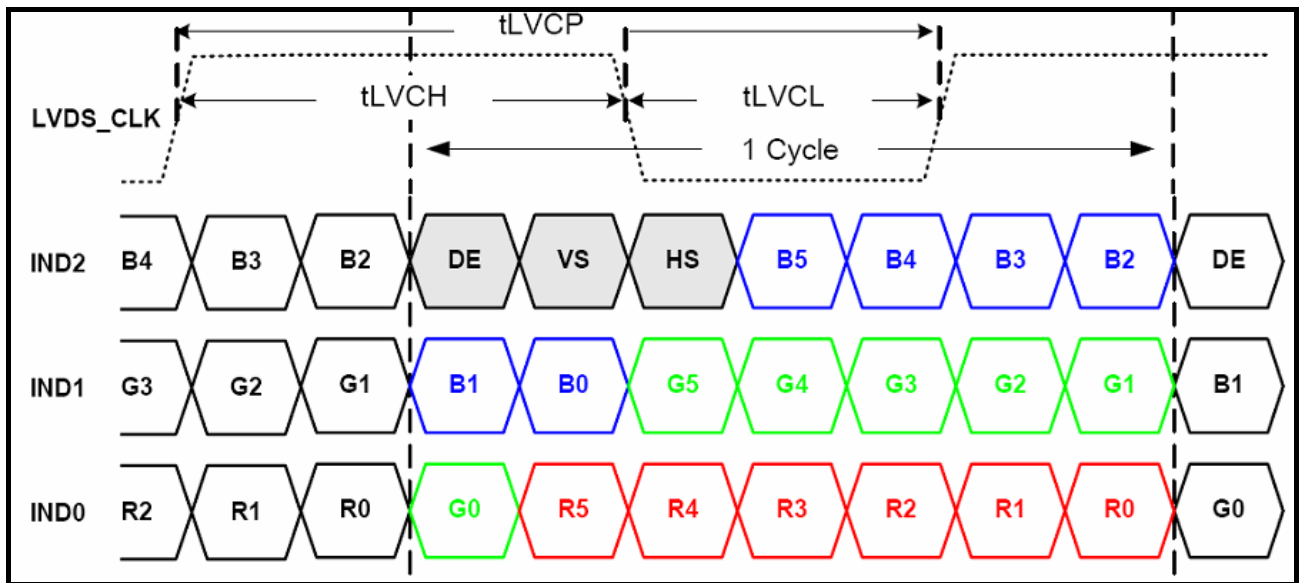
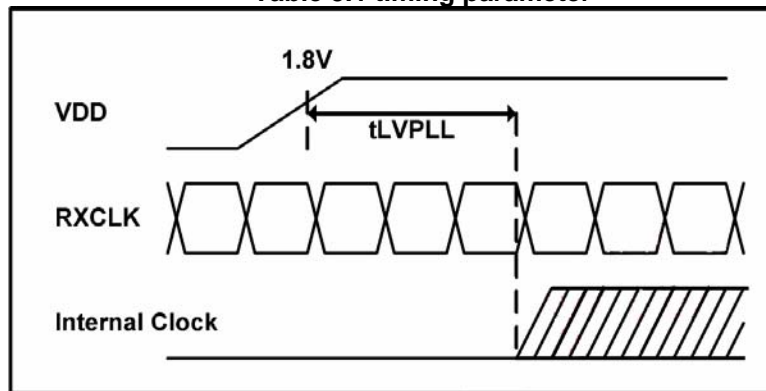

SW: Setup and Hold time  
Figure 5.1 Input signal data timing

## 5.2 Recommended Input Timing of LVDS transmitter

	Parameter	Symbol	Min.	Typ.	Max.	Unit	Remarks
Dclk frequency		1/Tclk	32	40	50	MHz	
Horizontal section	Horizontal total	Th	866	1056	1064	Tclk	
	Horizontal blanking	Thb	66	256	264	Tclk	
	Valid Data Width	Thd	800	800	800	Tclk	
Vertical section	Frame rate	-	-	60	70	Hz	
	Vertical total	Tv	604	628	800	Th	
	Vertical blanking	Tvb	4	28	200	Th	
	Valid Data Width	Tvd	600	600	600	Th	

Note: DE signal is necessary.

### Input Timing Control Conditions

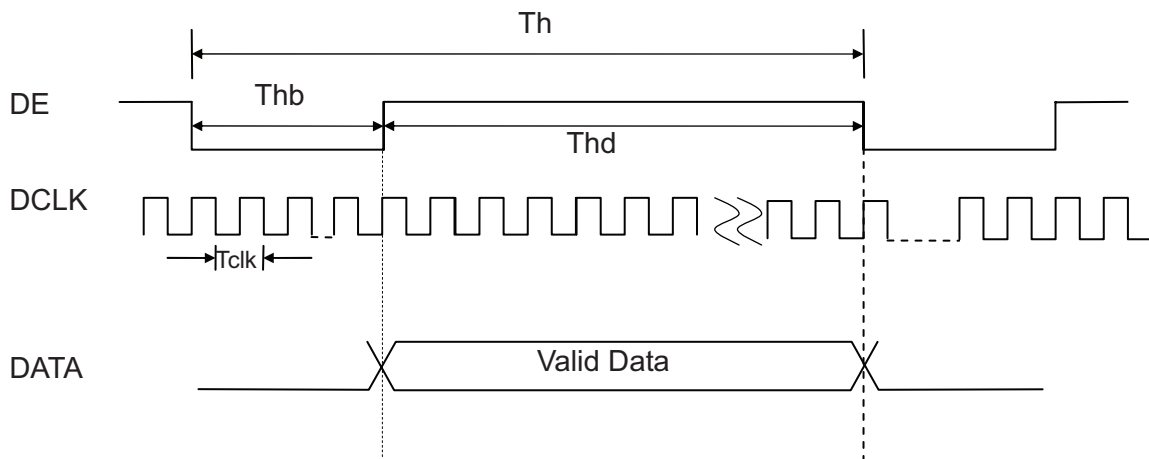
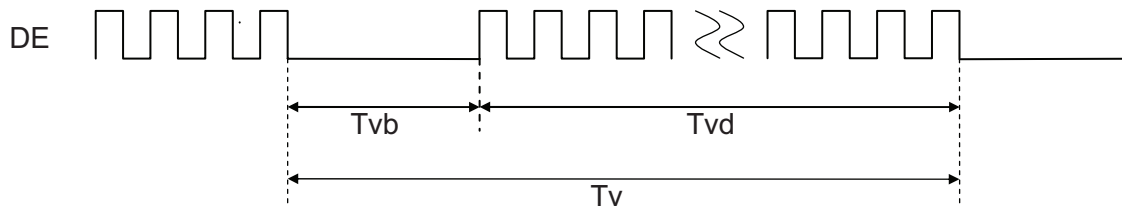



### 5.3 Power On/Off Sequence

Item	Symbol	Min	Typ	Max	Unit	Remark
VDD 3.0V to signal starting	Tp1	0	-	50	ms	
Signal starting to backlight on	Tp2	150	-	-	ms	
Signal off to VDD 3.0V	Tp3	0	-	50	ms	
Backlight off to signal off	Tp4	150	-	-	ms	

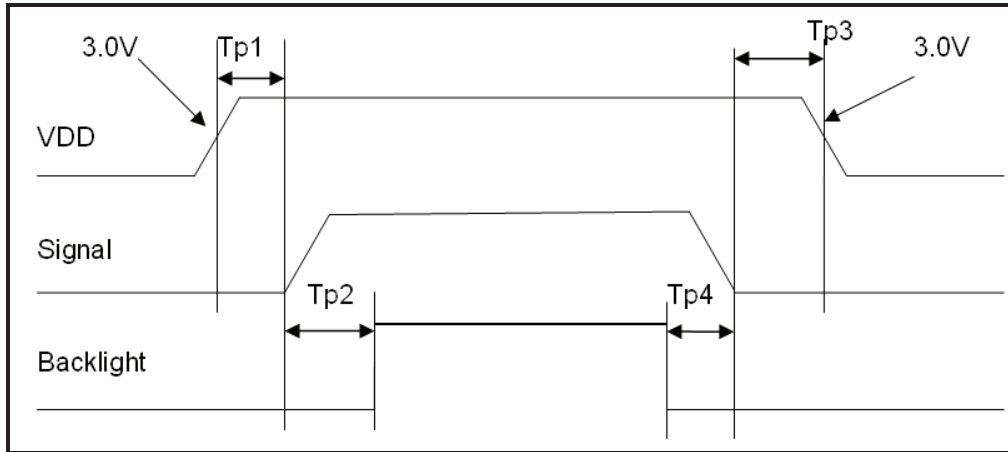

## 6 Optical Characteristics

### 6.1 Optical Specification

Ta=25°C

Item	Symbol	Condition	Min	Typ	Max	Unit	Remark	
View Angles	$\theta T$	$CR \geq 10$	50	60	-	Degree	Note 2	
	$\theta B$		60	70	-			
	$\theta L$		60	70	-			
	$\theta R$		60	70	-			
Contrast Ratio	CR	$\theta=0^\circ$	300	400	-	-	Note1 Note3	
Response Time	T <sub>ON</sub>	25°C	-	10	15	ms	Note1	
	T <sub>OFF</sub>		-	15	25		Note4	
Chromaticity	White	Backlight is on	x	0.259	0.309	0.359	-	Note5 Note1
			y	0.284	0.334	0.384		
	Red		x	0.550	0.600	0.650		
			y	0.296	0.346	0.396		
	Green		x	0.283	0.333	0.383		
			y	0.516	0.566	0.616		
	Blue		x	0.092	0.142	0.192		
			y	0.065	0.115	0.165		
Uniformity	U	-	70	80	-	%	Note1 Note6	
NTSC	-	-	-	50	-	%	Note 5	
Luminance	L		350	400	-	cd/m <sup>2</sup>	Note1 Note7	

Test Conditions:

1. The ambient temperature is  $25 \pm 2^\circ\text{C}$ . humidity is  $65 \pm 7\%$
2. The test systems refer to Note 1 and Note 2.

**Note 1: Definition of optical measurement system.**

The optical characteristics should be measured in dark room. After 5 minutes operation, the optical properties are measured at the center point of the LCD screen. All input terminals LCD panel must be ground when measuring the center area of the panel.

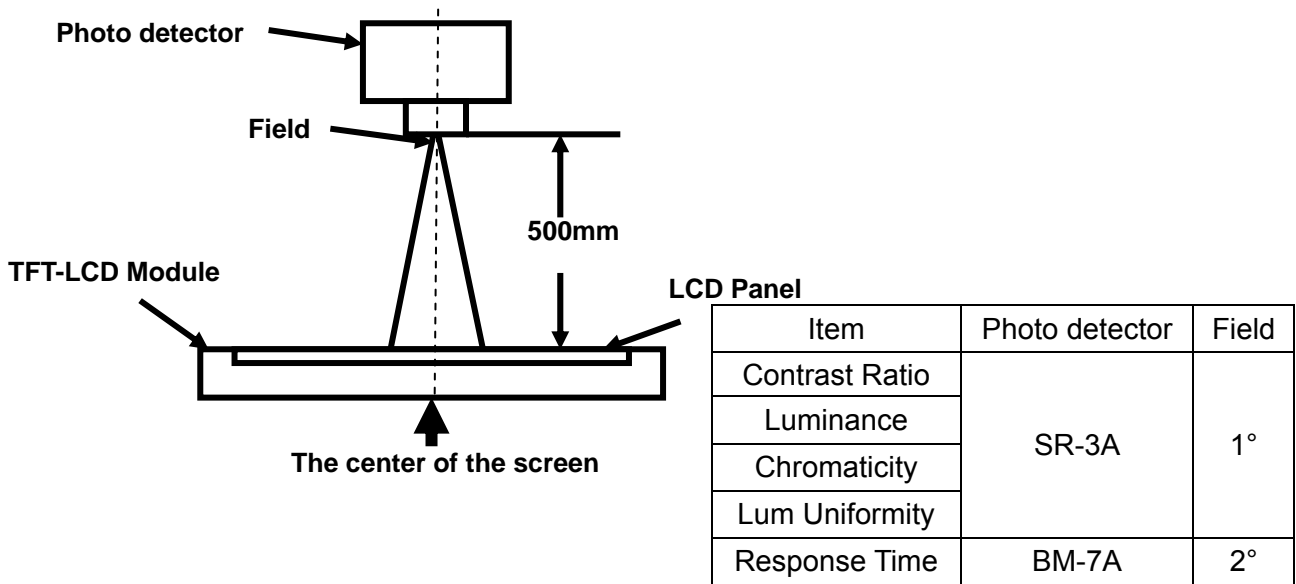

**Note 2: Definition of viewing angle range and measurement system.**

viewing angle is measured at the center point of the LCD by CONOSCOPE(ergo-80).

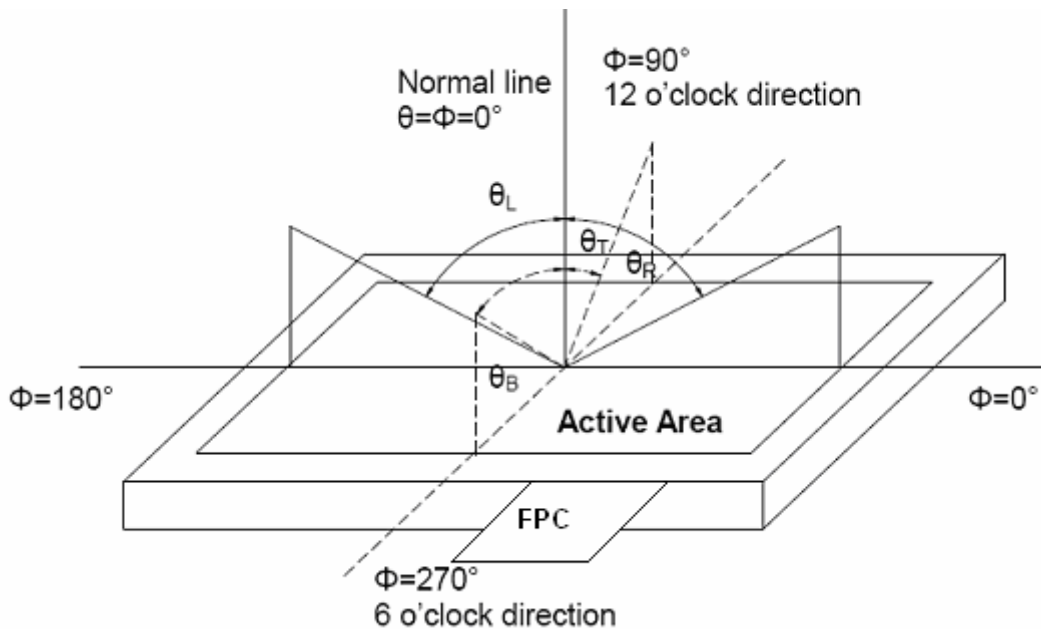

Fig. 1 Definition of viewing angle

---

Note 3: Definition of contrast ratio

$$\text{Contrast ratio (CR)} = \frac{\text{Luminance measured when LCD is on the "White" state}}{\text{Luminance measured when LCD is on the "Black" state}}$$

“White state “:The state is that the LCD should driven by  $V_{\text{white}}$ .

“Black state”: The state is that the LCD should driven by  $V_{\text{black}}$ .

$V_{\text{white}}$ : To be determined     $V_{\text{black}}$ : To be determined.

Note 4: Definition of Response time

The response time is defined as the LCD optical switching time interval between “White” state and “Black” state. Rise time ( $T_{\text{ON}}$ ) is the time between photo detector output intensity changed from 90% to 10%. And fall time ( $T_{\text{OFF}}$ ) is the time between photo detector output intensity changed from 10% to 90%.

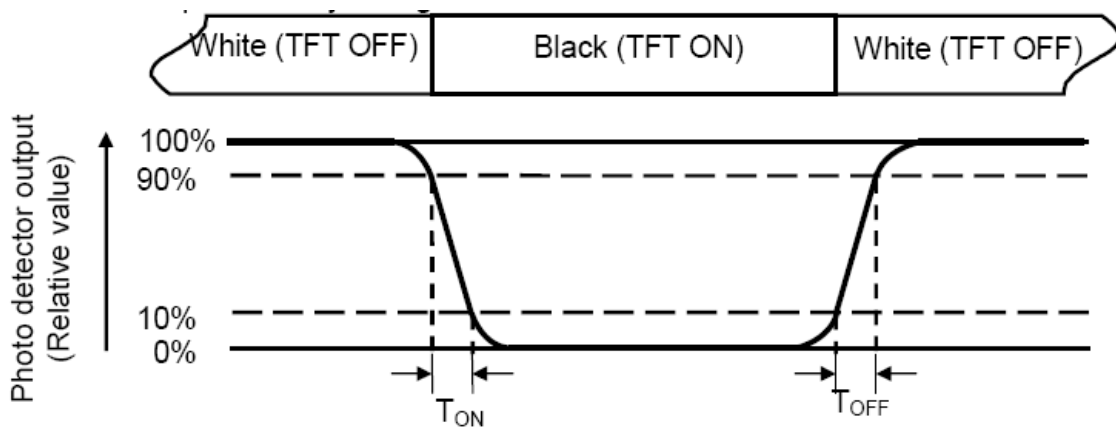

Note 5: Definition of color chromaticity (CIE1931)

Color coordinates measured at center point of LCD.

---

---

### Note 6: Definition of Luminance Uniformity

Active area is divided into 9 measuring areas (Refer Fig. 2). Every measuring point is placed at the center of each measuring area.

$$\text{Luminance Uniformity}(U) = L_{\min} / L_{\max}$$

L-----Active area length W----- Active area width

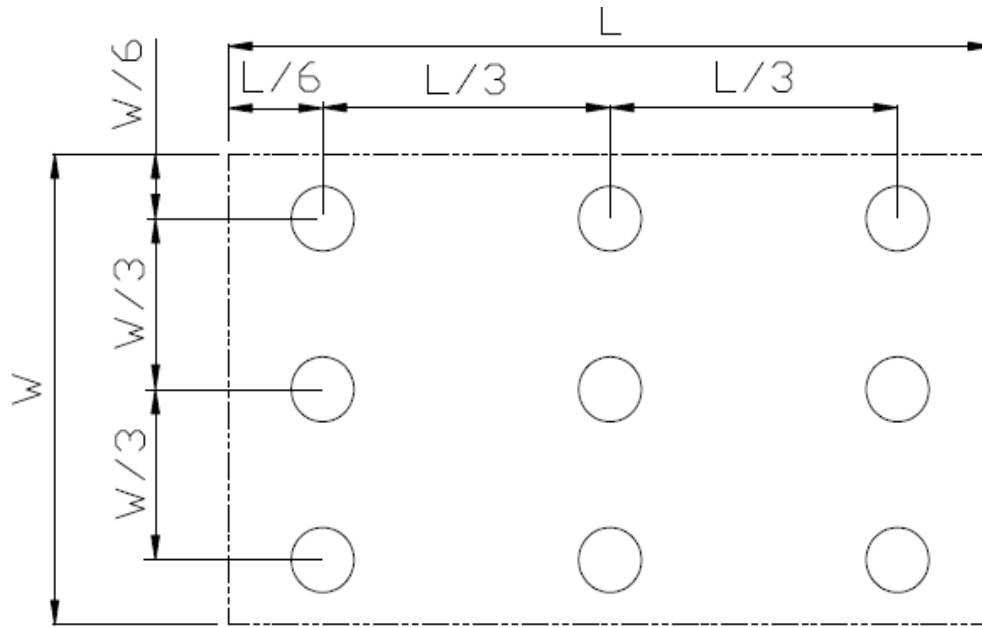

Fig. 2 Definition of uniformity

$L_{\max}$ : The measured maximum luminance of all measurement position.

$L_{\min}$ : The measured minimum luminance of all measurement position.

### Note 7: Definition of Luminance :

Measure the luminance of white state at center point.

---

## 7 Environmental / Reliability Test

No	Test Item	Condition	Remark
1	High Temperature Operation	Ts=+70°C, 240hrs	Note1 IEC60068-2-2,GB2423.2—89
2	Low Temperature Operation	Ta=-20°C, 240hrs	IEC60068-2-1 GB2423.1—89
3	High Temperature Storage (non-operation)	Ta=+80°C, 240hrs	IEC60068-2-2, GB2423.2—89
4	Low Temperature Storage (non-operation)	Ta=-30°C, 240hrs	IEC60068-2-1 GB2423.1—89
5	High Temperature & High Humidity Operation	Ta = +60°C, 90% RH max,240 hours	Note2 IEC60068-2-3, GB/T2423.3—2006
6	Thermal Shock (non-operation)	-20°C 30 min~+70°C 30 min, Change time:5min, 100 Cycles	Start with cold temperature, end with high temperature IEC60068-2-14,GB2423.22—87
7	Electro Static Discharge (operation)	C=150pF,R=330Ω, Air:±15Kv, Contact:±8Kv, 10times/terminal	IEC61000-4-2 GB/T17626.2—1998
8	Vibration (non-operation)	Frequency range:10~55Hz, Stroke:1.5mm Sweep:10Hz~55Hz~10Hz 2hours for each direction of X.y.z (6 hours for total)	IEC60068-2-6 GB/T2423.10—1995
9	Shock (non-operation)	80G 6ms, ±X,±Y,±Z 3 times for each direction	IEC60068-2-27 GB/T2423.5—1995
10	Package Drop Test	Height:80 cm,1 corner, 3 edges, 6 surfaces	IEC60068-2-32 GB/2423.8—1995
11	Package Vibration Test	Random Vibration: 0.015GxG/Hz for 5-200Hz, -6dB/Octave from 200-500Hz 2 hours for each direction of X,Y,Z (6 hours for total)	IEC60068-2-34

Note1: Ts is the temperature of panel's surface.

Note2: Ta is the ambient temperature of sample.

# 8 Mechanical Drawing

