

		Input Current [mA]	Gain [mA/mA]	電源 [V]	電流制限抵抗 [Ω]	Input resistance [Ω]	Channel current [mA]	Output Current [mA]
SiliconCore Technology SL6063E2現行品	lth	0.06	155	5	82000	550	9.39	417
	l dac	1.03	395	5	4300	550	407	
SiliconCore Technology SL6061C1類似品	lth	0.11	100	5	47000	547	10.52	412
	l dac	1.30	309	5	3300	547	402	
Texas Instruments LMH6525	lth	0.05	180	5	91000	580	9.83	417
	l dac	0.95	430	5	4700	580	407	
Renesas ISL58831	lth	0.06	165	5	82000	750	9.97	421
	l dac	0.82	250	5	5600	500	205	
	l 固定	1.03	200	5	4300	550	206	

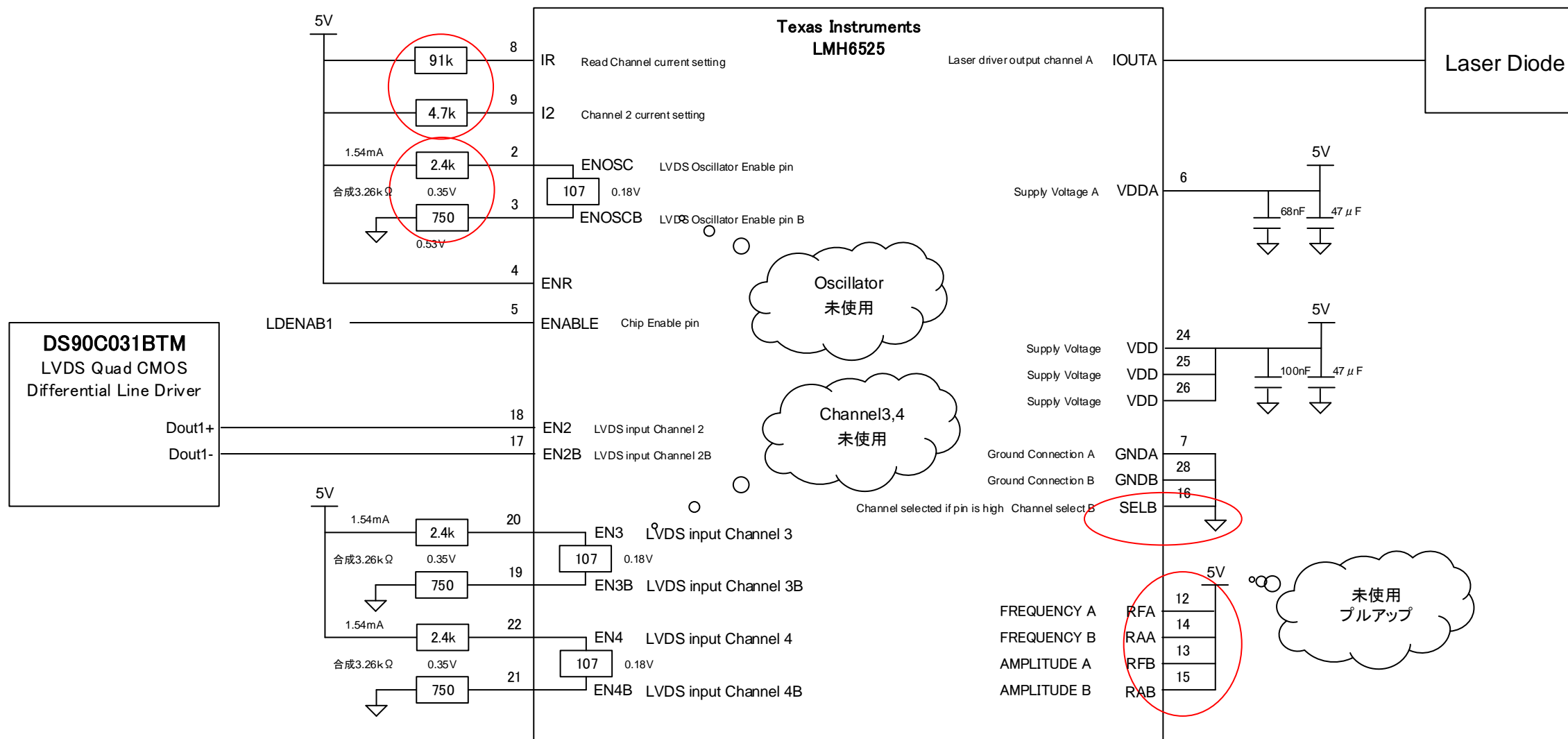

Table 2. IOU Control

ENABLE	ENR	EN2	EN3	EN4	IOU
0	X	X	X	X	OFF
1	0	0	0	0	OFF
1	1	0	0	0	$A_R * I_{INR}$
1	1	1	0	0	$A_R * I_{INR} + A_2 * I_{IN2}$
1	1	0	1	0	$A_R * I_{INR} + A_3 * I_{IN3}$
1	1	0	0	1	$A_R * I_{INR} + A_4 * I_{IN4}$