

NOTES:

1. SILKSCREEN ALL JUMPERS AND HEADERS.
2. PLACE ALL PARTS ON A 0 OR 90 DEGREE ORIENTATION.
3. HIGH SPEED SERIAL DATA SHOULD BE ROUTED AS SINGLE-ENDED 50 OHM TRANSMISSION LINES. ROUTING DISTANCE SHOULD BE 3 INCHES OR LESS.
4. USE FR4-370 MATERIAL.
5. PLACE TI LOGO IN TOP SIDE METAL

REVISIONS		
ECR	ECR NUMBER	DATE
	-----	--/--/--

Texas Instruments and its subsidiaries (TI) reserve the right to make changes to their products and publications or to discontinue any product or service without notice, and advise customers to obtain the latest version of relevant information to verify, before placing orders, that information being relied on is current and complete. All products are sold subject to the terms and conditions of sale supplied at the time of order acknowledgment, including those pertaining to warranty, patent infringement, and limitation of liability.

Customers are responsible for their applications using TI components. In order to minimize risks associated with applications using TI components, adequate design and operating safeguards must be provided by the customer to minimize inherent or procedural hazards. The information in this document is provided by TI as a courtesy and in no way constitutes a reference design. Any direct duplication of this design in its entirety is strictly prohibited without expressed written approval by TI. Furthermore, TI assumes no liability for applications assistance or customer product design. TI does not warrant or represent that any license, either express or implied, is granted under any patent right, copyright, mask work right, or other intellectual property right of TI covering or relating to any combination, machine, or process in which such semiconductor products or services might be or are used. TI's publication or information regarding any third party's products or services does not constitute TI's approval, warranty or endorsement thereof.

Copyright © 2011. Texas Instruments Incorporated



TEXAS INSTRUMENTS			
SCHEMATIC TITLE			
HD3SS212 EVM			
PAGE TITLE			
ENGINEER	DATE	SIZE	DOCUMENT NUMBER
U. Fields	07/20/11	B	
LAYOUT	DATE	REV	SHEET
		A	1 of 6

ENGINEER	DATE
U. Fields	07/20/11
LAYOUT	DATE
RELEASED	DATE

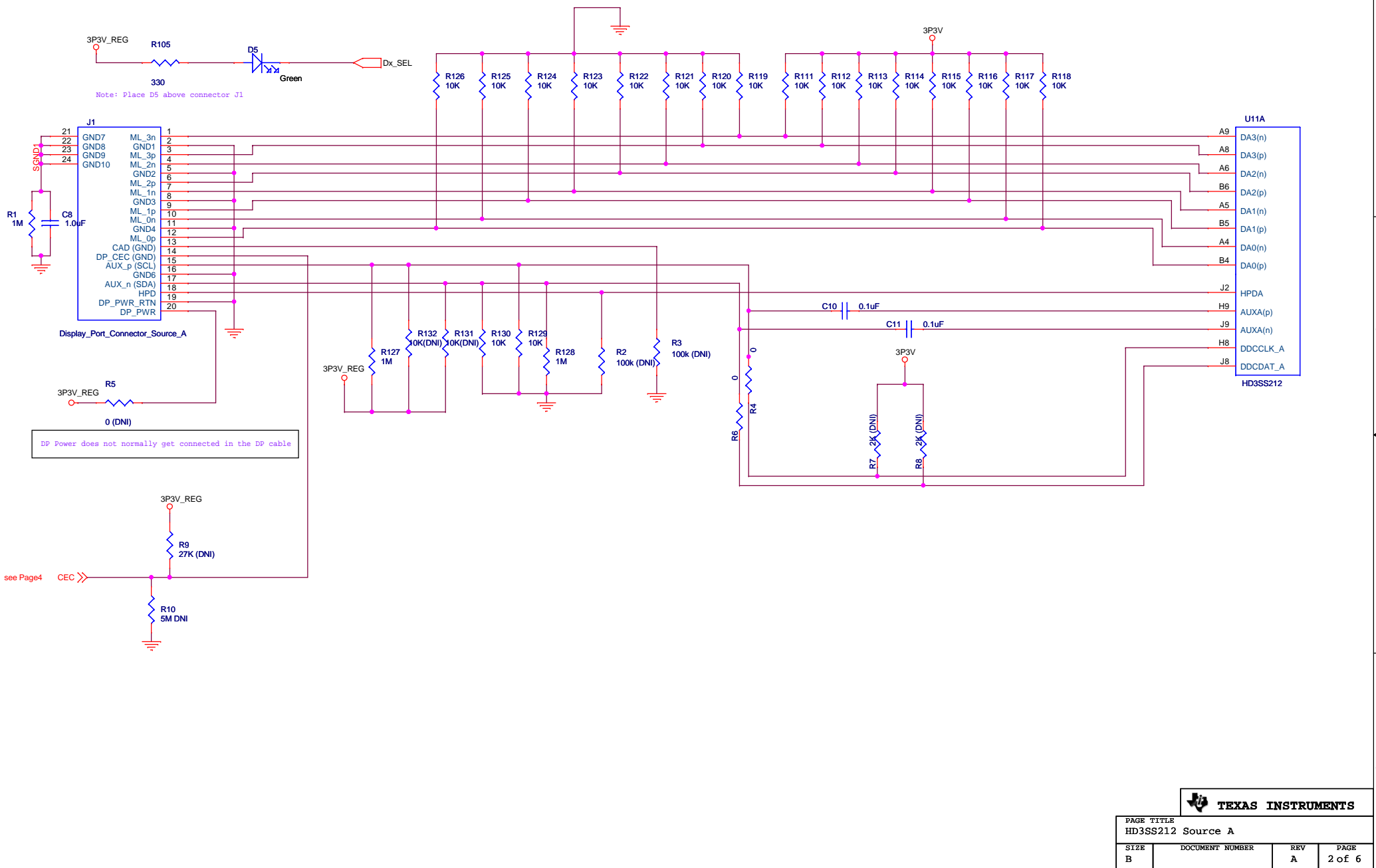

Note: Place D5 above connector J1

DP Power does not normally get connected in the DP cable

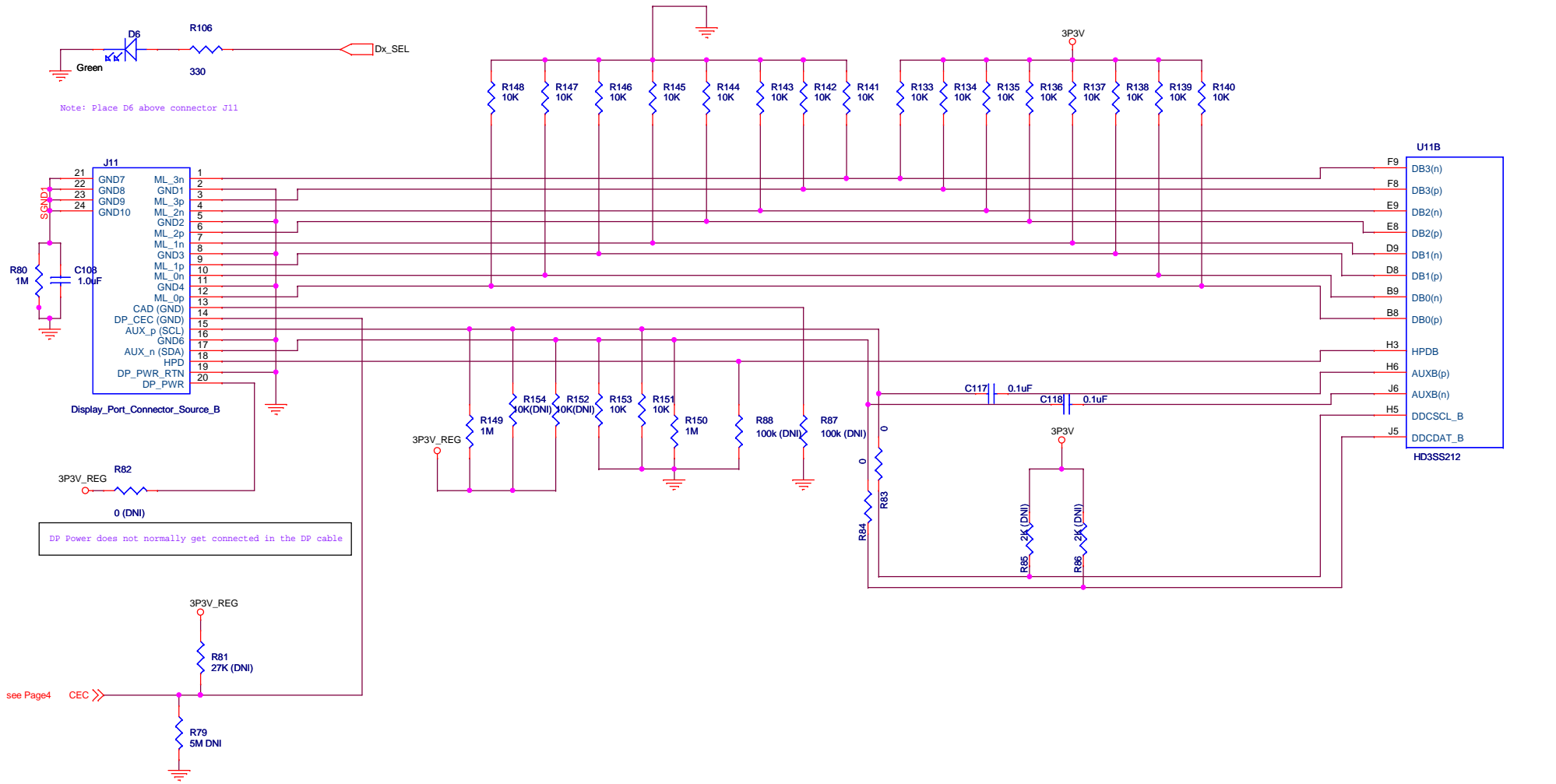

PAGE TITLE			
HD3SS212 Source B			
S12E	DOCUMENT NUMBER	REV	PAGE
B		A	3 of 6

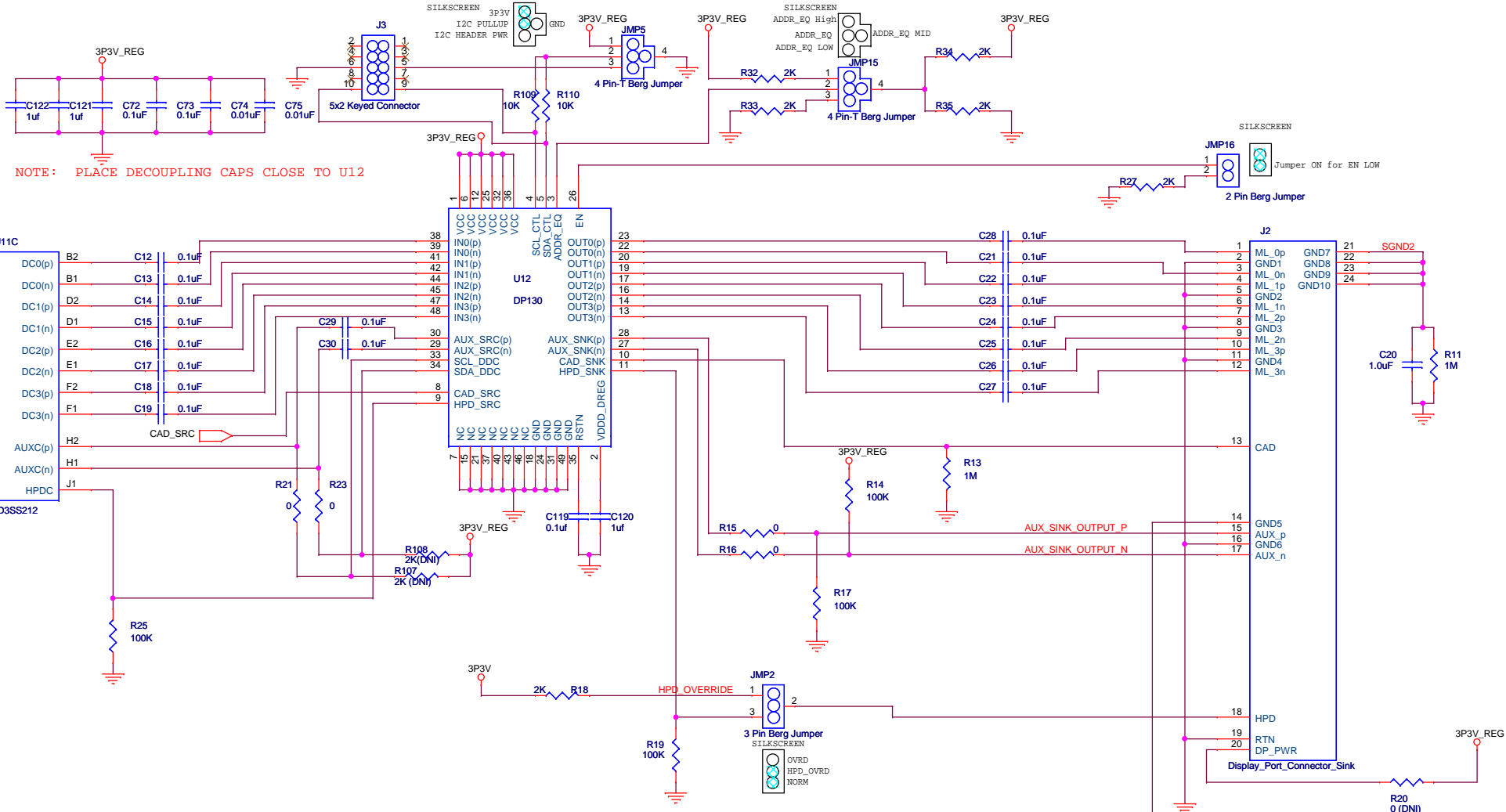

NOTE: PLACE DECOUPLING CAPS CLOSE TO U12

NOTE: HPD OVERRIDE
 SHORT 2->3 FOR NORMAL HPD
 SHORT 1->2 FOR FORCED HPD (HIGH)

see Pages 2 & 3

R20 can be installed to provide DP source power for dongle support



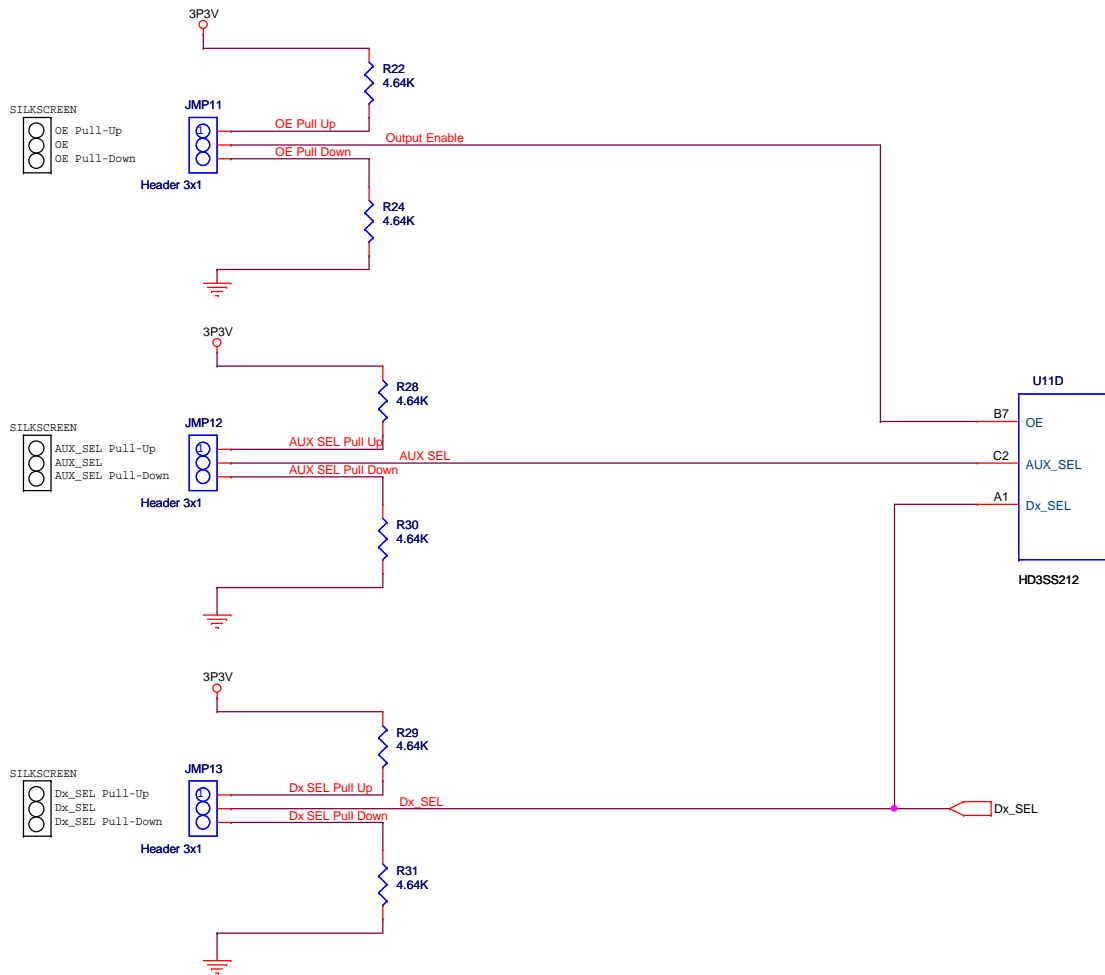

PAGE TITLE HD3SS212 CONTROL			
SIZE B	DOCUMENT NUMBER	REV A	PAGE 5 of 6

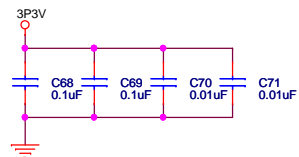
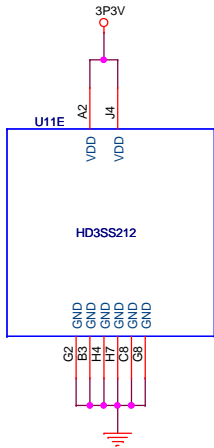
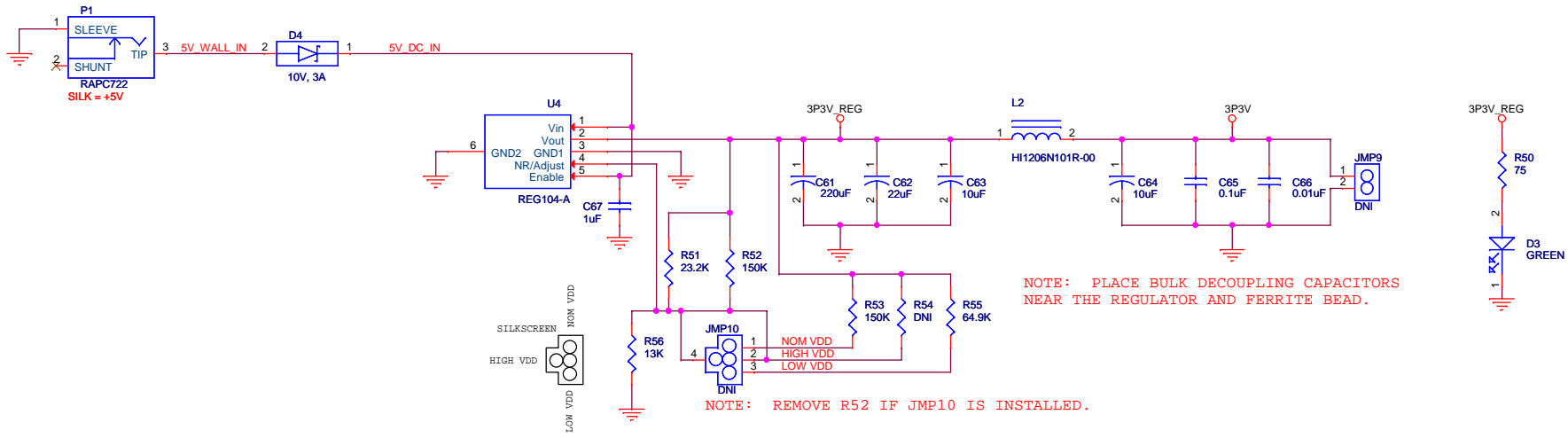

PAGE TITLE POWER			
SIZE B	DOCUMENT NUMBER	REV A	PAGE 6 of 6