

Project title			Variant [No Variations]		
Title			Drawn:		
SKU			Checked:		
Size: A3			Approved:		
Number: 9		Revision:			
Date: 17.05.2023		Time: 07:44:22			
File: MF-DBE.3-U_SW - PHY GbE.SchDoc		Sheet 9 of 12			

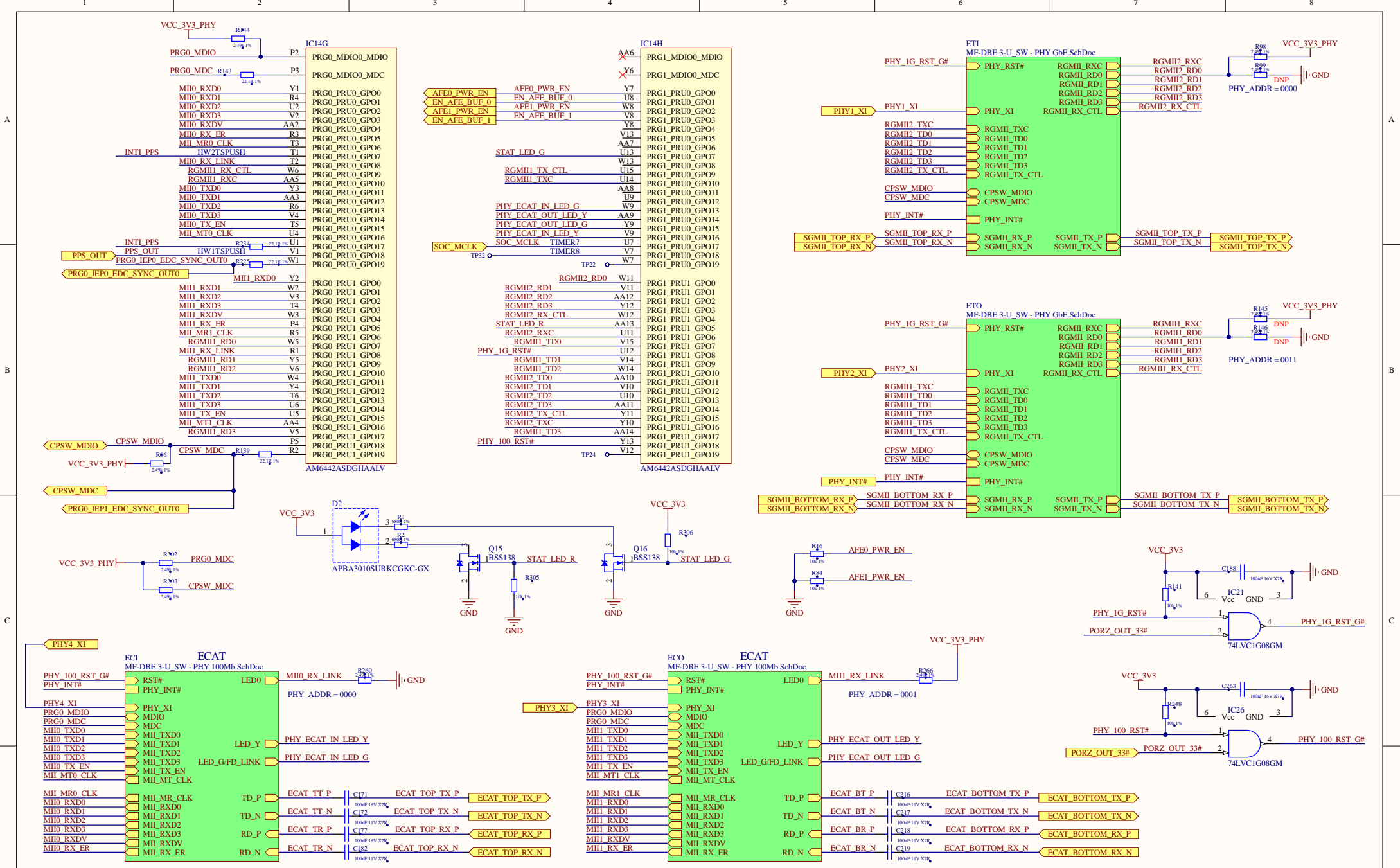

Project title			Variant [No Variations]		
Title			Drawn:		
SKU			Checked:		
Size: A3			Approved:		
Date: 17.05.2023		Time: 07:44:26		Revision:	
File: MF-DBE.3-U_SW - SoC.ETH.SchDoc		Sheet 8 of 12		DEWESoft®	