

Error Report, TCA9617A

12.03.2026

Keba Industrial Automation GmbH, moe

TCA9617A is used as level shifter and bus repeater for DDC on DVI

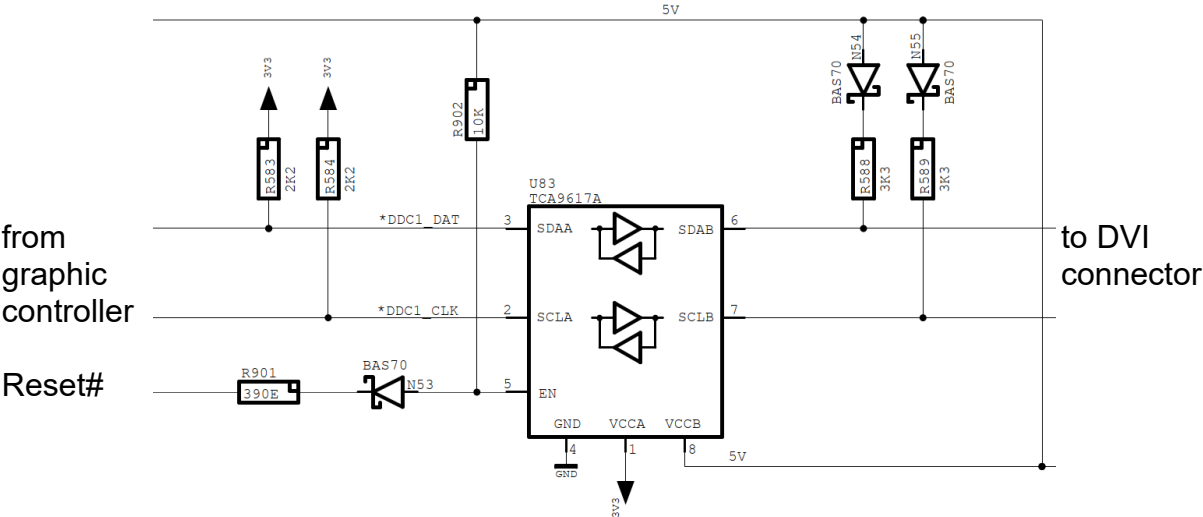

Power Sequence:



Channel assignment:

- Channel 1: VCCB (5V), Pin 8
- Channel 2: VCCA (3V3), Pin 1
- Channel 3: -
- Channel 4: -

VCCB is always higher than VCCA during power up, as required in the datasheet.

VCCB doesn't start at zero but at about 1V because of backdriving from the monitor. That shouldn't be according to the VESA-specification but is unfortunately common for almost all monitors. As it can be seen in the schematic, backdriving can't happen via the external pullup-resistors, because we have inserted diodes for decoupling. So the backdriving must happen via internal clamping diodes in the TCA9617A. But anyway, this shouldn't make any problems.

Working Circuit

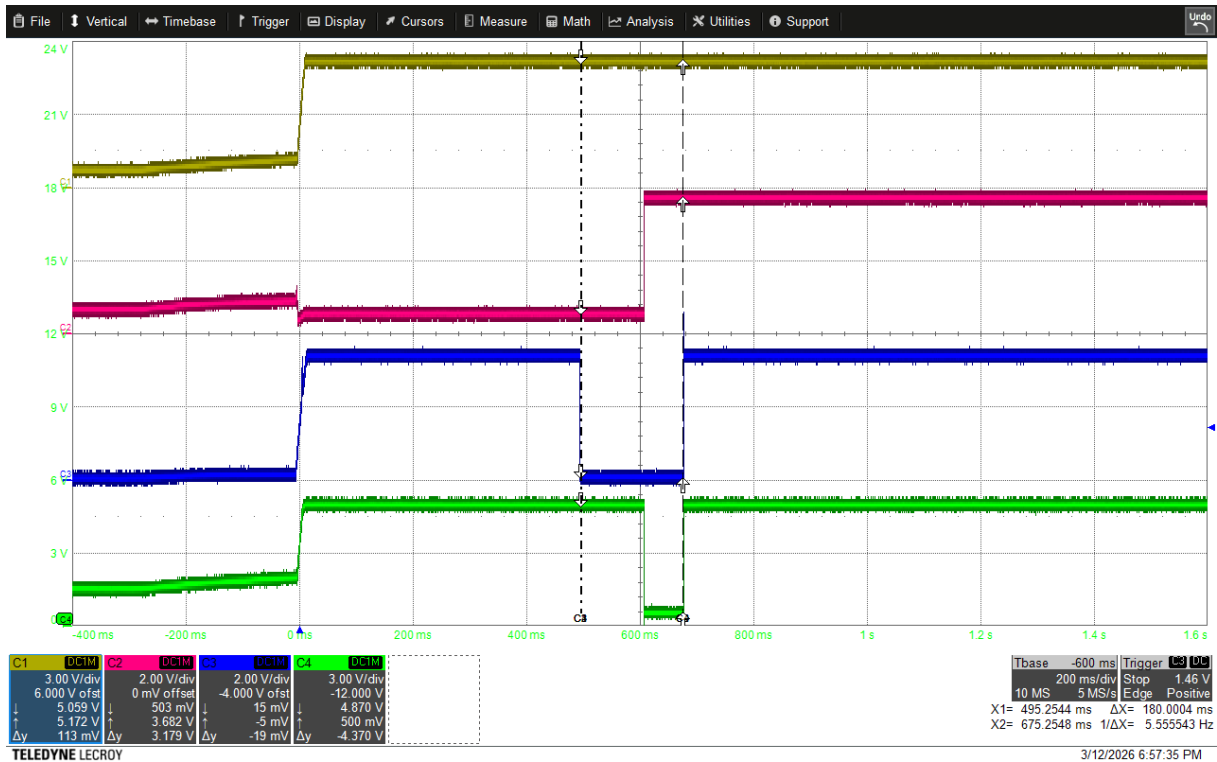

Channel assignment:

- Channel 1: VCCB (5V), Pin 8
- Channel 2: EN (3V3-Signal), Pin 5
- Channel 3: SDAA (3V3-Signal), Pin 3
- Channel 4: SDAB (5V-Signal), Pin 6

- Channel 1 shows VCCB as a reference.
- Channel 2 is the enable input (Pin 5). As it is inactive (=low) during powerup, the outputs are disabled. After about 600ms it gets active (=high).
- Channel 3 shows the data input signal to SDAA from the graphic controller. It rises to high during powerup, because the I2C-Bus is idle at that time and therefore the pullup-resistor (R583) pulls the signal high. After about 500ms the signal is driven low by the graphic controller for about 180ms.
- Channel 4 shows the data output signal SDAB to the DVI-connector. It doesn't follow the input signal (SDAA) immediately, because the output is disabled at the beginning (see Channel 2, EN). When EN gets active (=high), the output SDAB follows the input (SDAA) and stays low until the input gets high again.

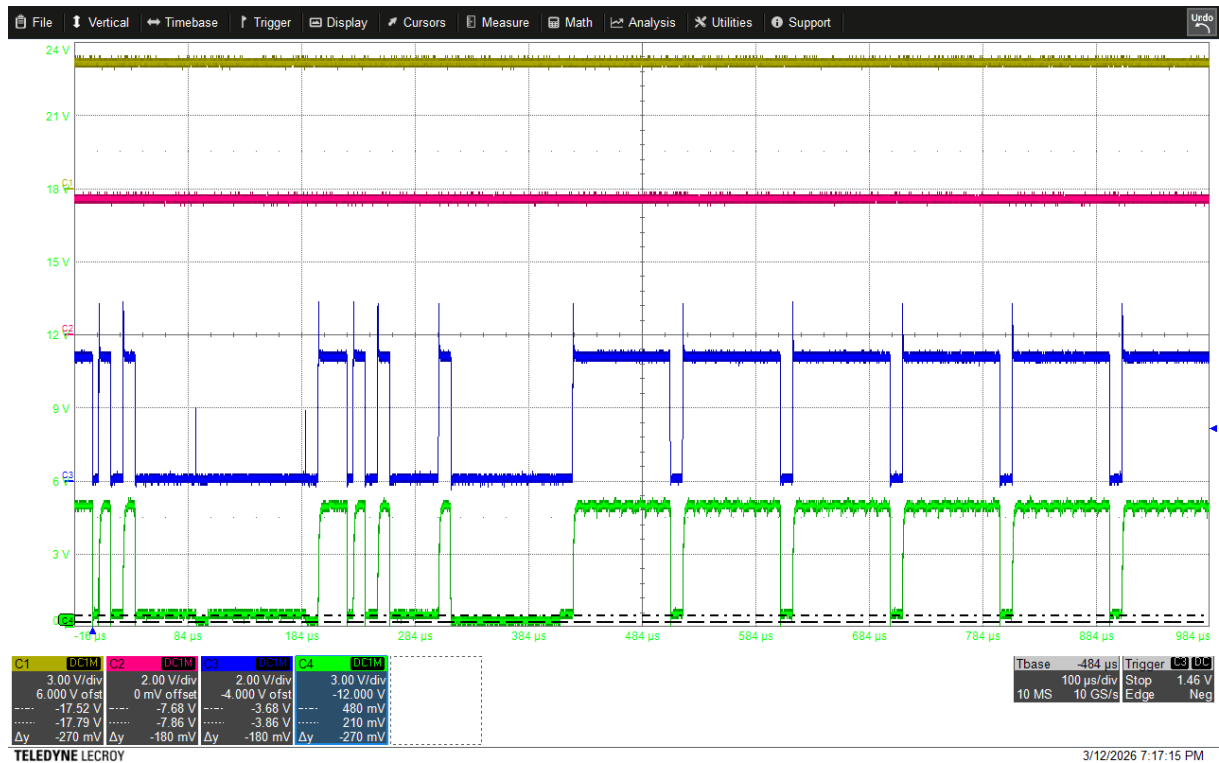

Channel assignment:

- Channel 1: VCCB (5V), Pin 8
- Channel 2: EN (3V3-Signal), Pin 5
- Channel 3: SDAA (3V3-Signal), Pin 3
- Channel 4: SDAB (5V-Signal), Pin 6

- The picture shows a part of the communication on the DDC.
- Channel assignment is the same as before.
- VCCB (Channel 1) is switched on and EN (Channel 2) is permanently active.
- Communication is bidirectional. SDAB follows SDAA and vice versa. The data direction can be seen at the low level of SDAB (Channel 4). Each low which reaches about 270mV (lower cursor) comes from the monitor and goes to the graphic controller, while each low which reaches about 480mV (upper cursor) is an output from the TCA9617A (buffered low) and goes to the monitor.

Summary:

The TCA9617A works as it should.

Failing Circuit



Channel assignment:

- Channel 1: VCCB (5V), Pin 8
- Channel 2: EN (3V3-Signal), Pin 5
- Channel 3: SDAA (3V3-Signal), Pin 3
- Channel 4: SDAB (5V-Signal), Pin 6

- Channel 1 shows VCCB as a reference.
- Channel 2 is the enable input (Pin 5). As it is inactive (=low) during powerup, the outputs should be disabled. After about 600ms it gets active (=high).
- Channel 3 shows the data input signal to SDAA from the graphic controller. It rises to high during powerup, because the I2C-Bus is idle at that time and therefore the pullup-resistor (R583) pulls the signal high. After about 500ms the signal is driven low by the graphic controller for about 180ms.
- Up to here everything is identical to the working circuit.
- Channel 4 shows the data output signal SDAB to the DVI-connector. Here is a big difference to the working circuit. Although EN is inactive at powerup, the output SDAB is enabled and drives the signal low from the beginning (immediately when VCCB is powered up).
→ That is wrong!



Channel assignment:

- Channel 1: VCCB (5V), Pin 8
- Channel 2: EN (3V3-Signal), Pin 5
- Channel 3: SDAA (3V3-Signal), Pin 3
- Channel 4: SDAB (5V-Signal), Pin 6

- The picture has the same scale as at the working circuit.
- Channel assignment is the same as before.
- VCCB (Channel 1) is switched on and EN (Channel 2) is permanently active.
- Channel 3 (SDAA) shows the start of the communication from the graphic controller but Channel 4 (SDAB) does not follow and remains permanently low.
- The same applies to SCLB (Pin 7) which does not follow SCLA (Pin 2). This was measured but not recorded.

Summary:

The TCA9617A doesn't work properly but drives both outputs B low, which is wrong!