

IMPORTANT NOTICE

The circuit design files provided by Texas Instruments are for reference only and have not undergone product level testing to insure compliance to customer product specifications. In addition, the circuit design files may contain additional circuitry intended for lab evaluation and not required for end product applications. TI assumes no liability for customer product design. Customers are responsible for their products and applications using TI components. To minimize the risks associated with customer products and applications, customers should provide adequate design and operating safeguards.

POWER PLANES: 1.5VD, 1.5VA, VDDIO, 3.3VA, and PCIE_3.3V

POWER TRACES (15mil width minimum):
PCIE_3.3VAUX, ICS_VDDA, VDD_33_COMB, VDD_33_COMB_IO, VDD_15_COMB, TPSFB, TPS1.8, TPS1.5.

POWER TRACES (50mil width minimum):
PCIE_12V

CRITICAL ROUTING:

1. TXP/TXN must be matched to within 5mils.
2. TXP/TXN must have a 100-ohms differential impedance
3. RXP/RXN must be matched to within 5mils.
4. RXP/RXN must have a 100-ohms differential impedance
5. REFCLKP/REFCLKN must be matched to within 5mils
6. REFCLKP/REFCLKN must have a 100-ohms differential impedance
7. P0_S_REFCLKP/P0_S_REFCLKN must be matched to within 5mils
8. P0_S_REFCLKP/P0_S_REFCLKN must have a 100-ohms differential impedance.
9. REFCLK+/REFCLK- must be matched to within 5mils.
10. REFCLK+/REFCLK- must have a 100-ohms differential impedance.
11. The following signals need to be matched to within 50mils. These signals also need to have a single-ended impedance of 50-ohms +/- 10%: TX_DATA[15:0], TX_DATAK[1:0], TX_CLK, TXCOMPLIANCE, and TXELECIDLLE.
12. The following signals needs to be matched to within 50mils. These signals also need to have a single-ended impedance of 50-ohms +/- 10%: RX_CLK, RX_DATA[15:0], RX_DATAK[1:0], RX_STATUS[2:0], RX_VALID, and RX_ELECIDLLE.

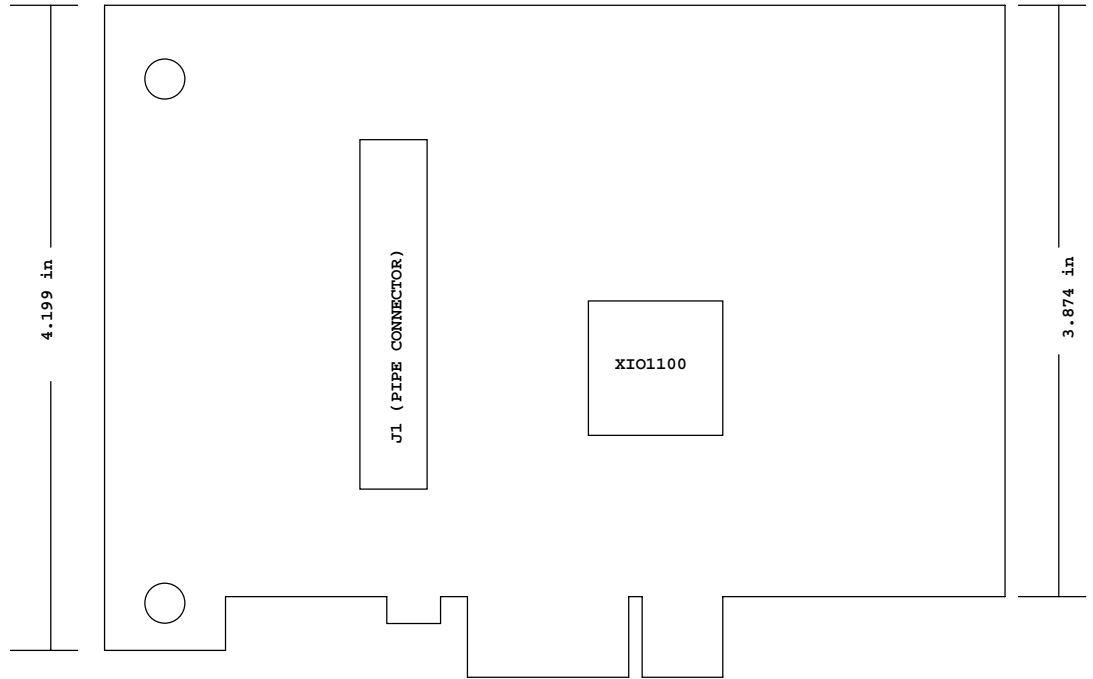

 TEXAS INSTRUMENTS	
Copyright 2006, Texas Instruments Inc.	
XIO1100 PIPE EVM (TITLE PAGE)	
SIZE B	DWG NO:
SCALE: NONE	Friday, February 10, 2006
Sheet 1	of 5

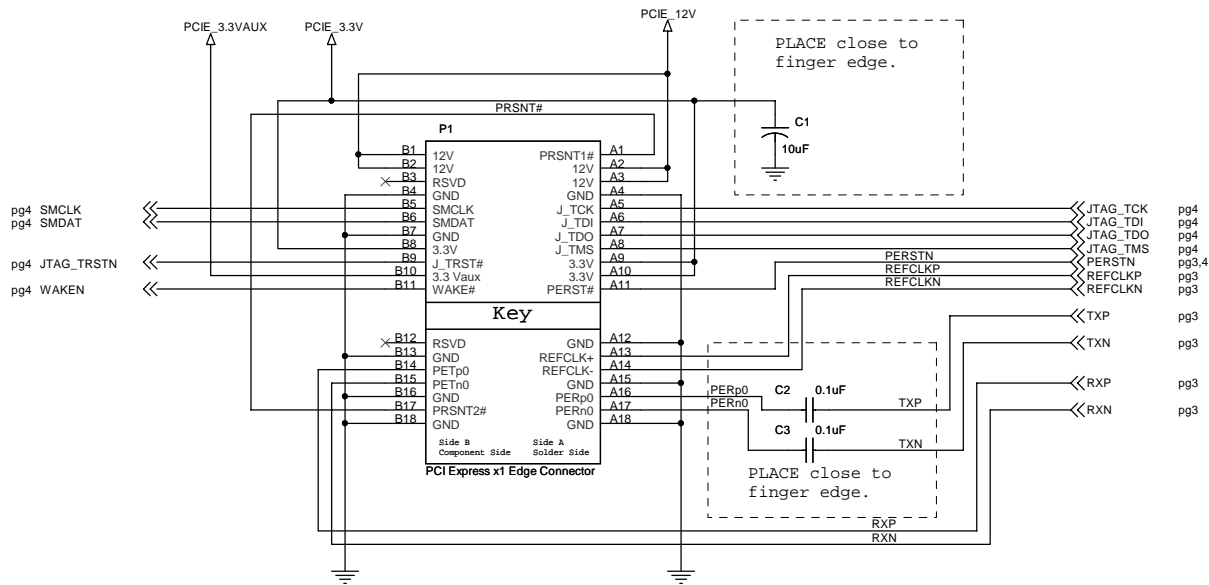

NOTES:

- 1.) WAKE# (B11) is not connected. System Vendor provides pullup.
- 2.) 3.3VAUX (B10) is not connected.
- 3.) Required that all PCI Express add-in cards implement variable length edge finger pads and tie the PRSNT1# and PRSNT2# signals together on the add-in card. Refer to the PCI Express Card Electromechanical Spec section 3.2.
- 4.) Each differential signal pair must be 100-ohm differential impedance with each single-ended lane measuring in the range of 50-ohm to 55-ohm impedance to ground.
- 5.) The differential pair should be routed such that the skew within differential pairs is less than 5 mils.

MATCH to within 5mils

 TEXAS INSTRUMENTS	
Copyright 2006, Texas Instruments Inc.	
PCI EXPRESS X1 CONNECTOR	
SIZE B	DWG NO:
SCALE: NONE	Monday, February 13, 2006
Sheet 2	of 5

PLACE R15 AND R18
CLOSE TO U2

NEEDS TO BE PULLED DOWN

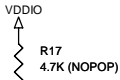

PLACE CLOSE TO U2

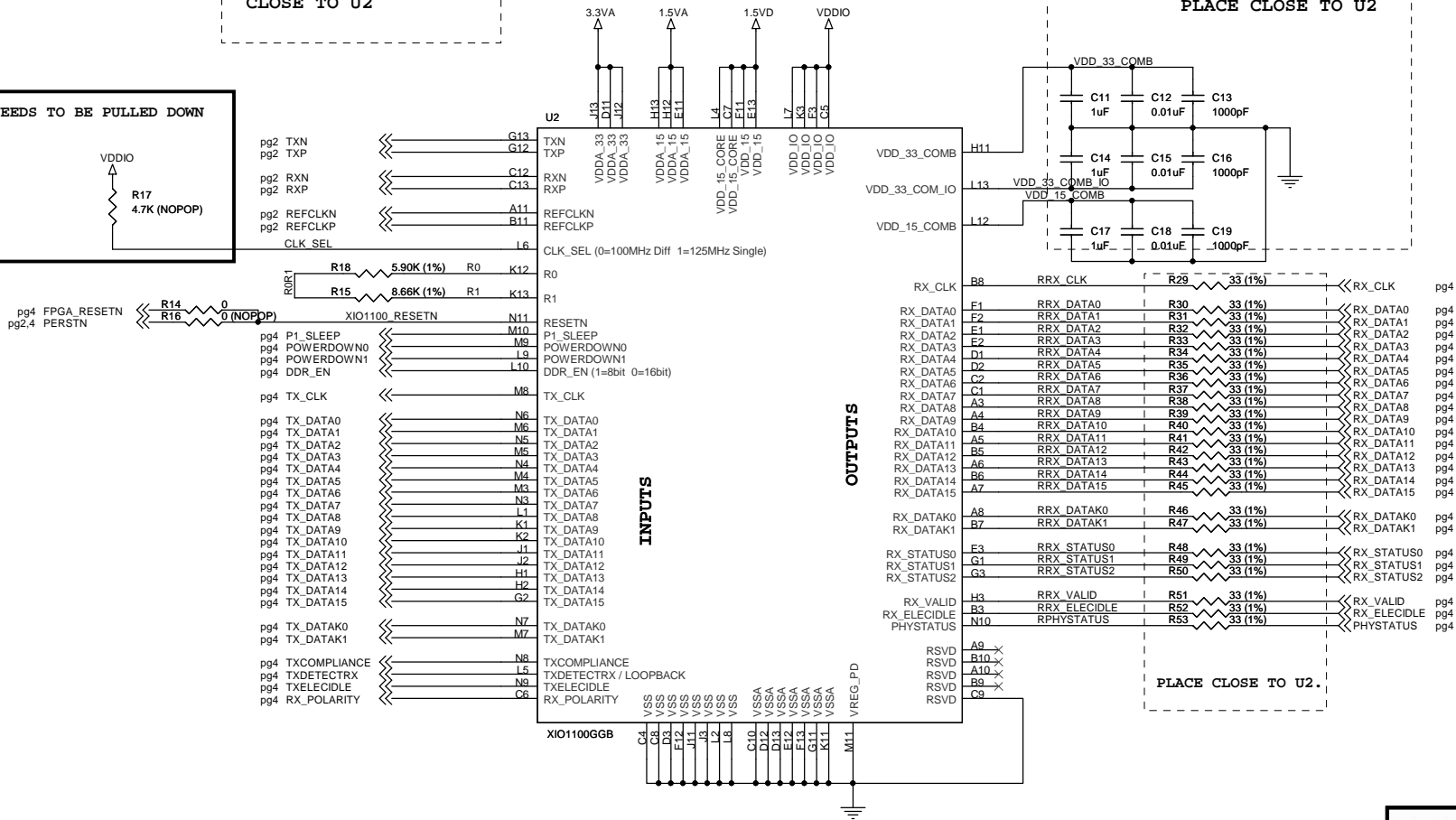
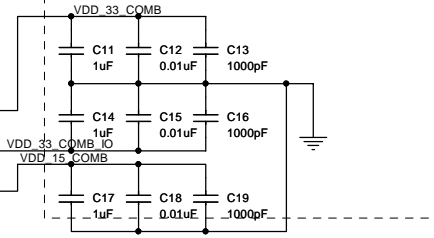

INPUTS

OUTPUTS

PLACE CLOSE TO U2.

TEXAS INSTRUMENTS

Copyright 2006, Texas Instruments Inc.

XIO1100 (100-GGB)

SIZE B	DWG NO:
SCALE: NONE	Wednesday, March 15, 2006
Sheet 3	of 5

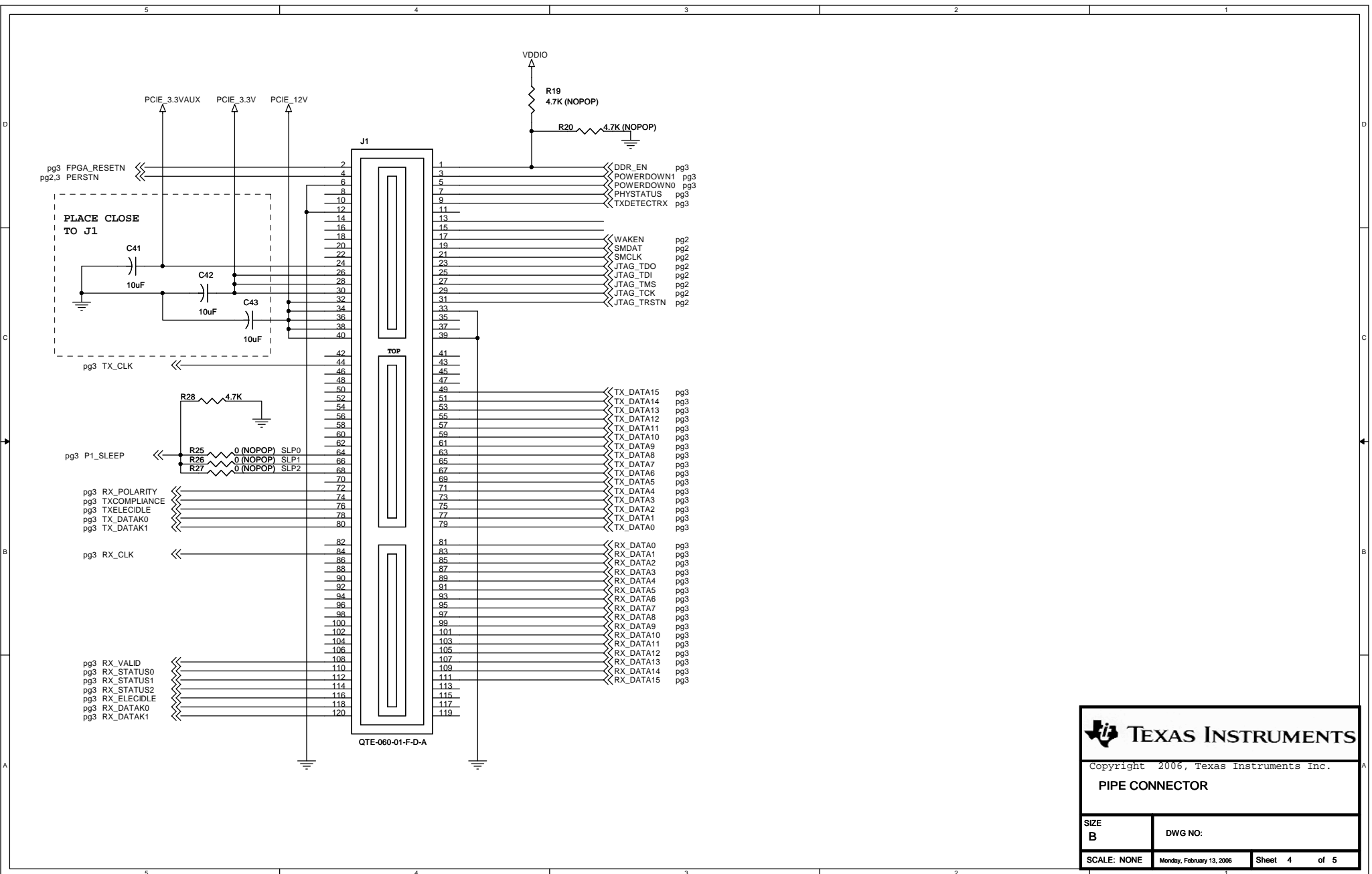

 TEXAS INSTRUMENTS	
Copyright 2006, Texas Instruments Inc.	
PIPE CONNECTOR	
SIZE B	DWG NO:
SCALE: NONE	Monday, February 13, 2006
Sheet 4	of 5

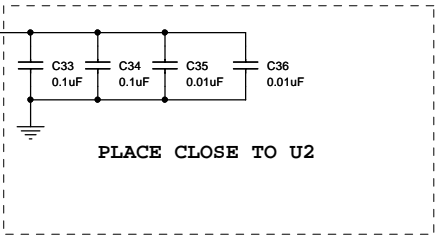
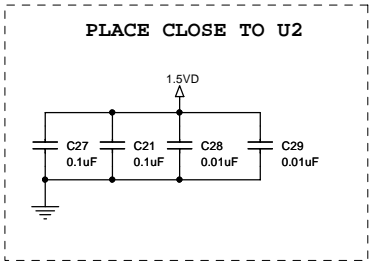
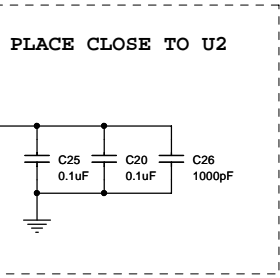
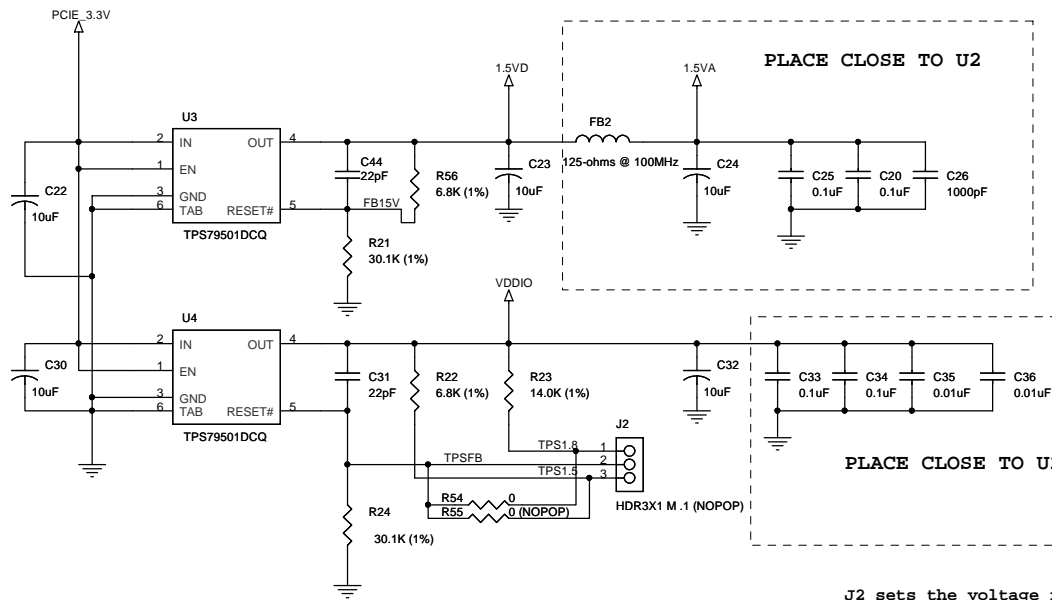

J2 sets the voltage for VDDIO:
 1-2 = 1.8V
 2-3 = 1.5V

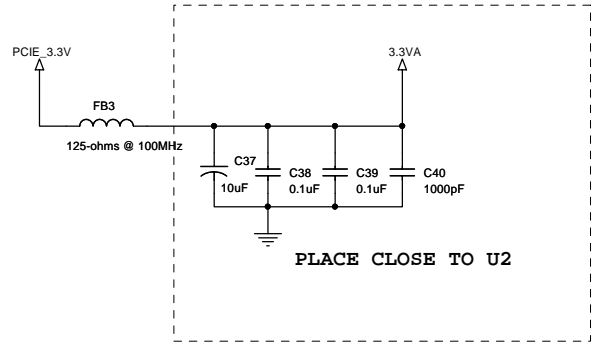

 TEXAS INSTRUMENTS	
Copyright 2006, Texas Instruments Inc.	
POWER	
SIZE B	DWG NO:
SCALE: NONE	Friday, February 17, 2006
Sheet 5	of 5