

- Front Light\_uC <<
- Front Indicator\_uC <<
- Dipper\_uC <<
- Wiper\_uC <<
- Rear Indicator\_uC <<
- Spare1\_uC <<
- Spare2\_uC <<
- Spare3\_uC <<
- V\_5V <<
- GND <<

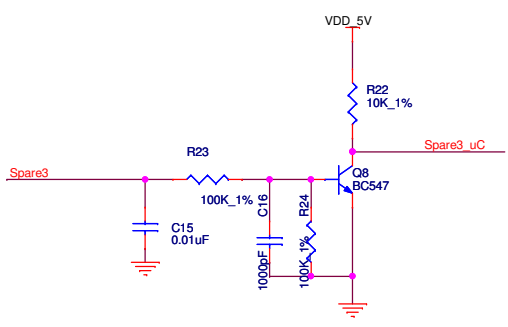

Title	<Title>	
Size	Document Number	Rev
B	<Doc>	<RevCod>
Date:	Thursday, March 26, 2015	Sheet 1 of 3

V\_12V <<<  
 LS1 <<<  
 LS2 <<<  
 LS3 <<<  
 LS4 <<<  
 LS5 <<<  
 LS6 <<<  
 LS7 <<<  
 GND <<<  
 V\_5V <<<

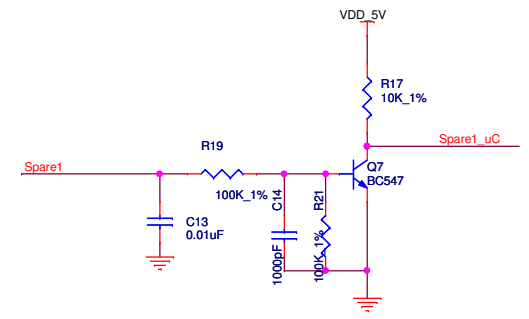
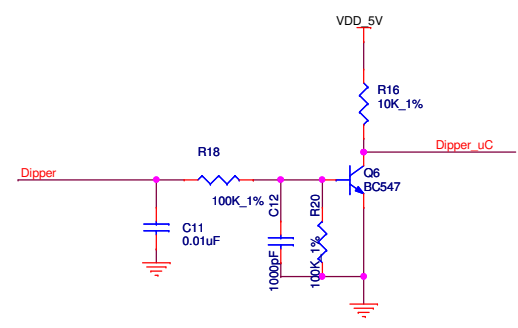
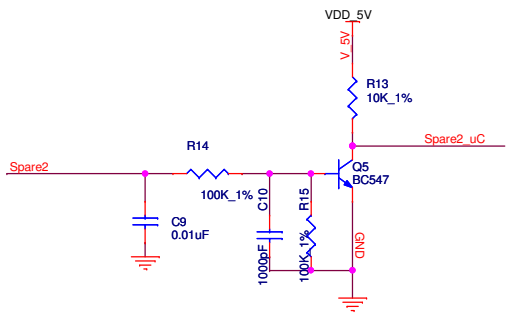
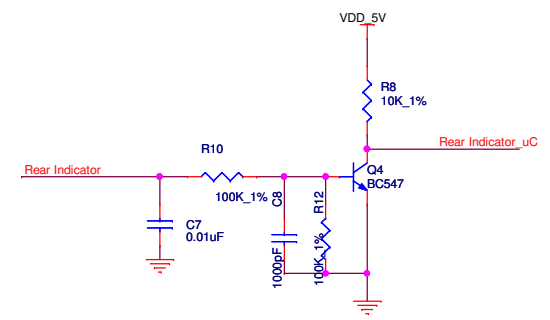
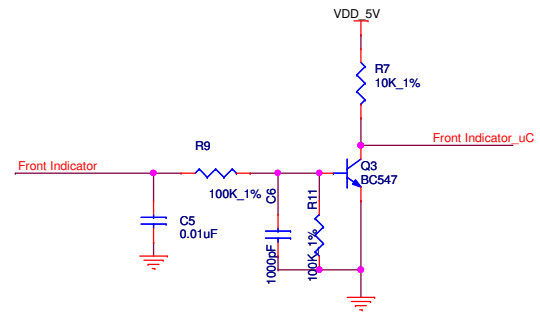
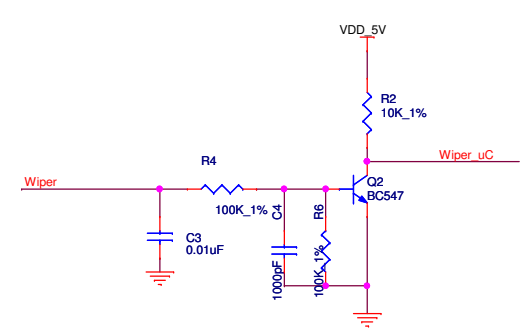
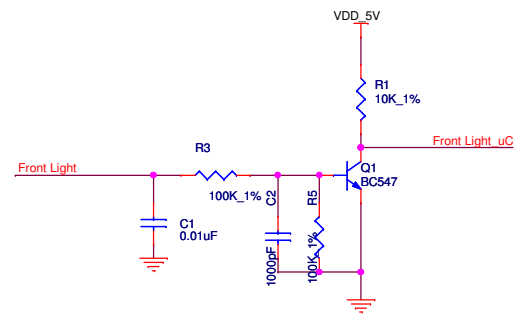
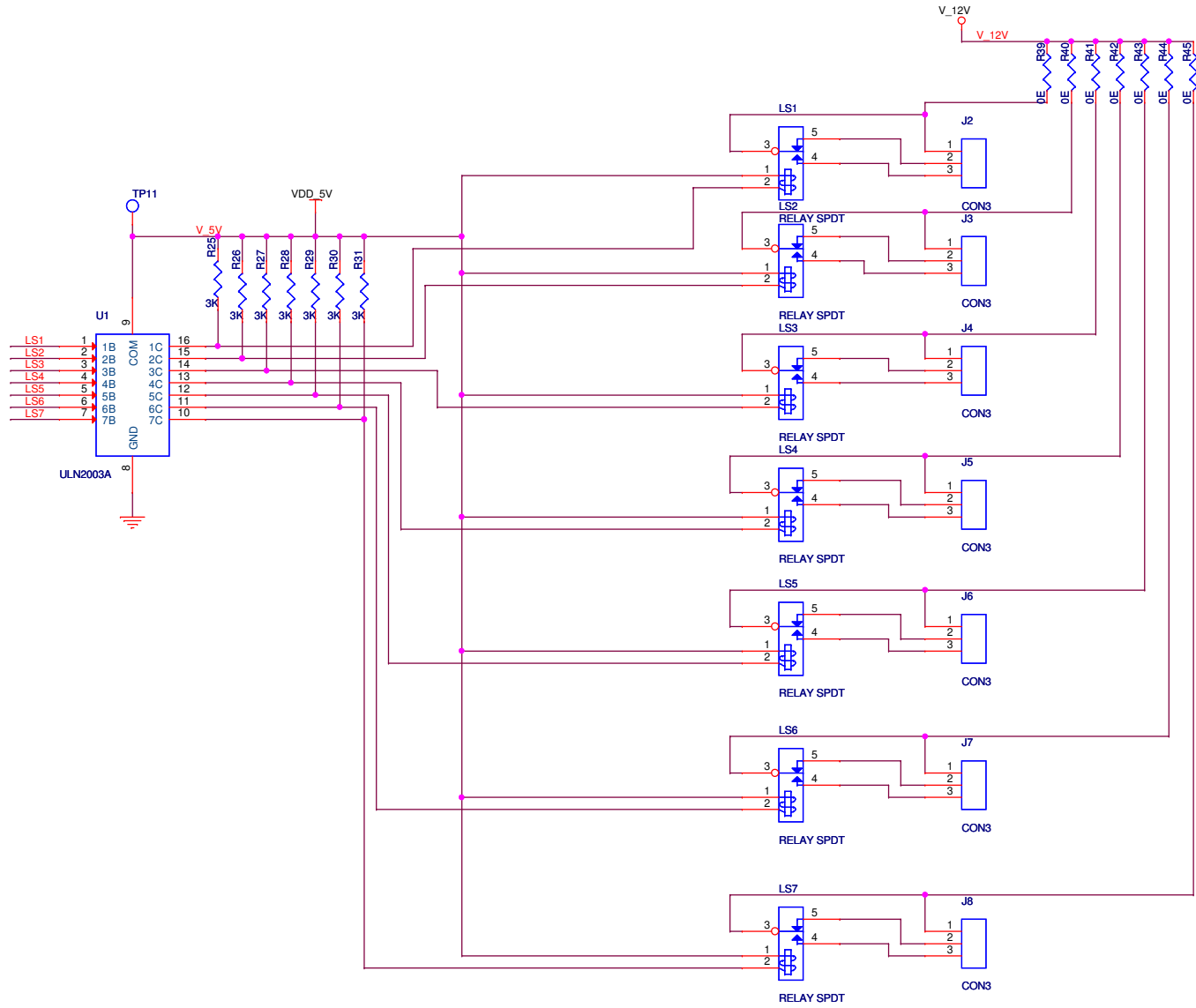

- MH1
- MHOLE\_3.2MM\_PTH
- MH2
- MHOLE\_3.2MM\_PTH
- MH3
- MHOLE\_3.2MM\_PTH
- MH4
- MHOLE\_3.2MM\_PTH

Title	<Title>	
Size	Document Number	Rev
B	<Doc>	<RevCod
Date:	Thursday, March 26, 2015	Sheet 2 of 3

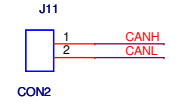
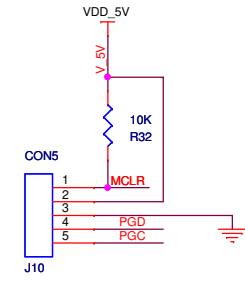
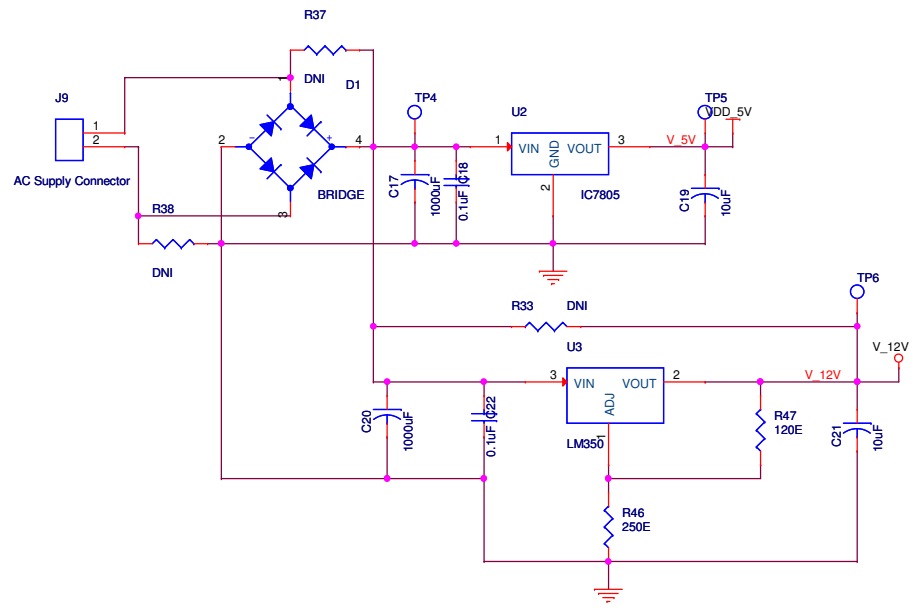

- << V\_5V
- << GND
- << Front Light\_uC
- << Front Indicator\_uC
- << Dipper\_uC
- << Wiper\_uC
- << Rear Indicator\_uC
- << Spare1\_uC
- << Spare2\_uC
- << Spare3\_uC
- << LS1
- << LS2
- << LS3
- << LS4
- << LS5
- << LS6
- << LS7
- << V\_12V

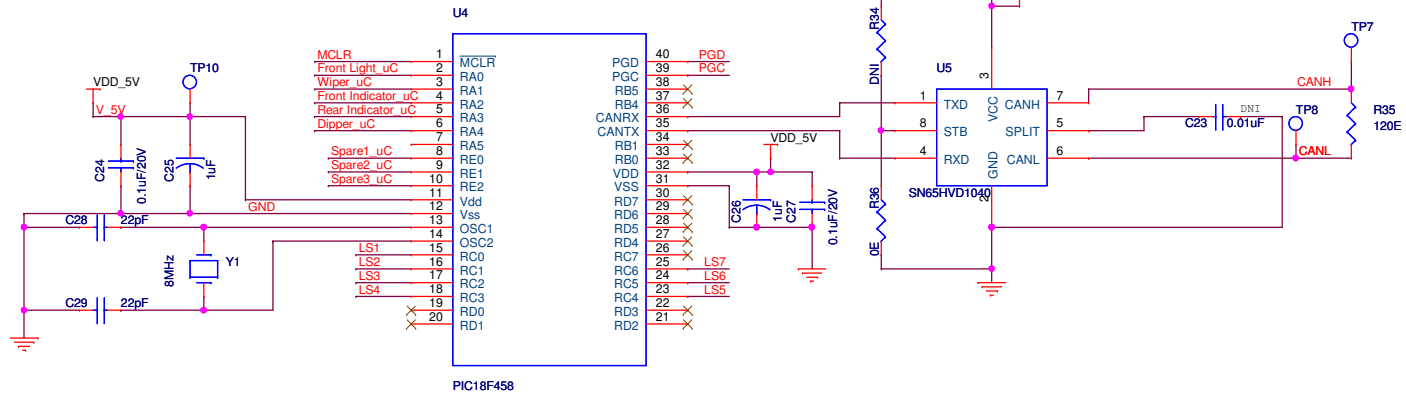

Title		<-Title-
Size B	Document Number	<-Doc-
Date:	Thursday, March 26, 2015	Sheet 3 of 3

Rev <RevCod