

LED_100/10 (yellow LED)
 100M : Low => turn on
 10M : High => turn off

LED_LINK (green LED)
 Ethernet Active : High => turn on

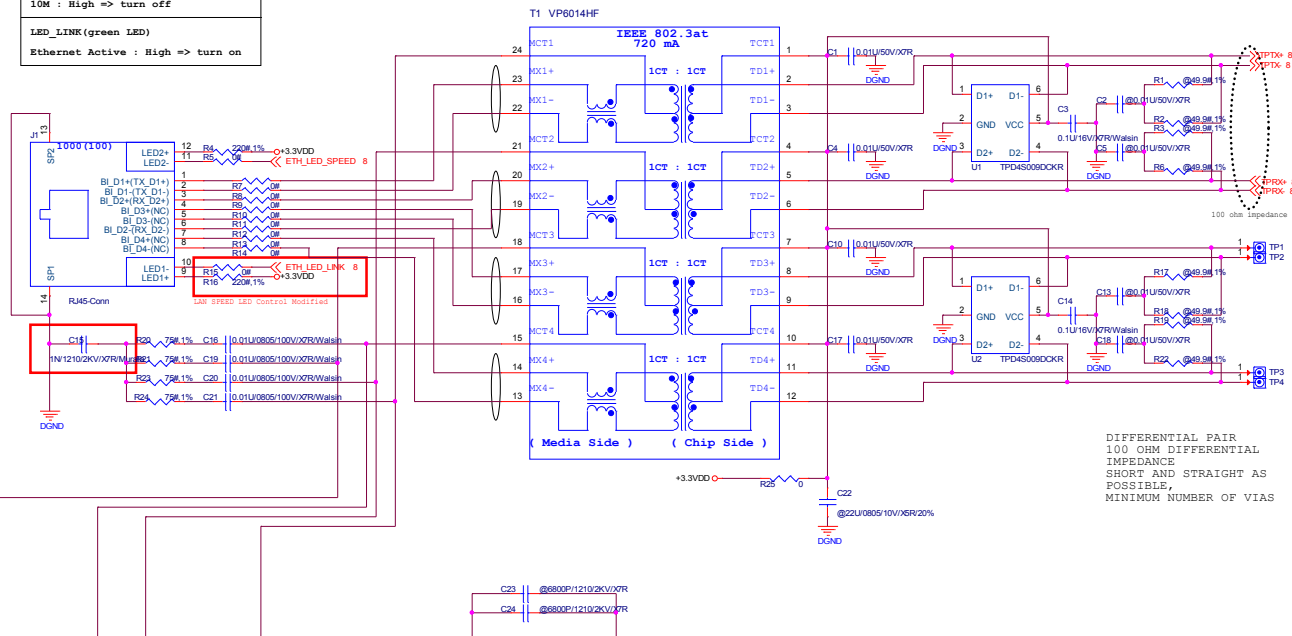

DIFFERENTIAL PAIR
 100 OHM DIFFERENTIAL
 IMPEDANCE
 SHORT AND STRAIGHT AS
 POSSIBLE,
 MINIMUM NUMBER OF VIAS

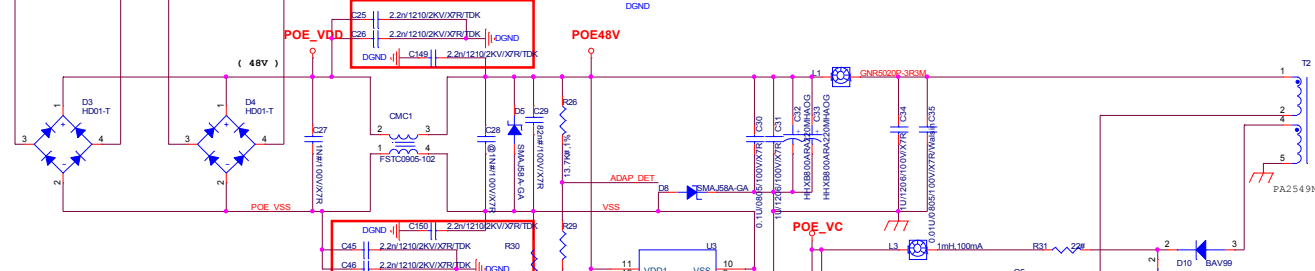
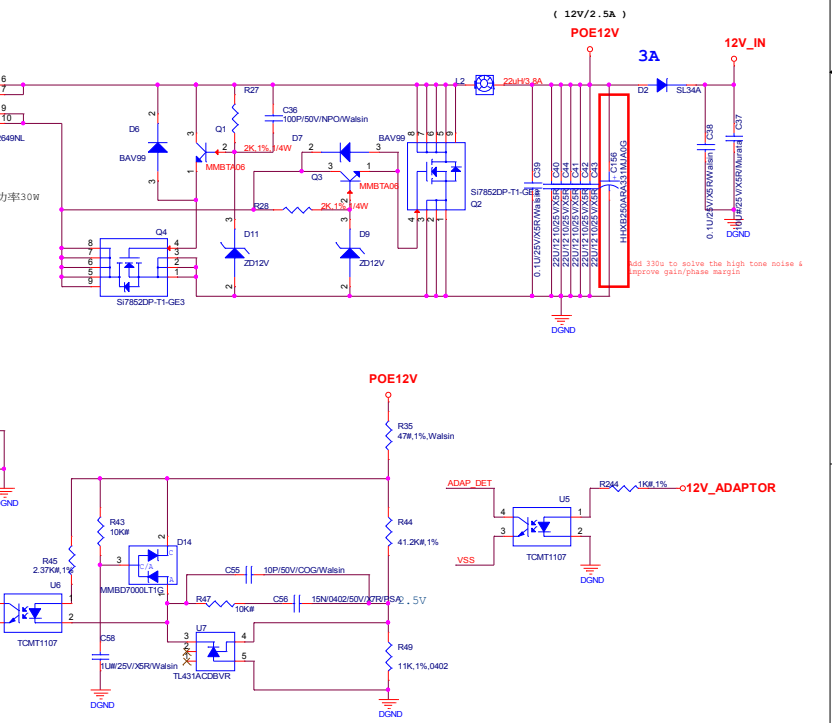
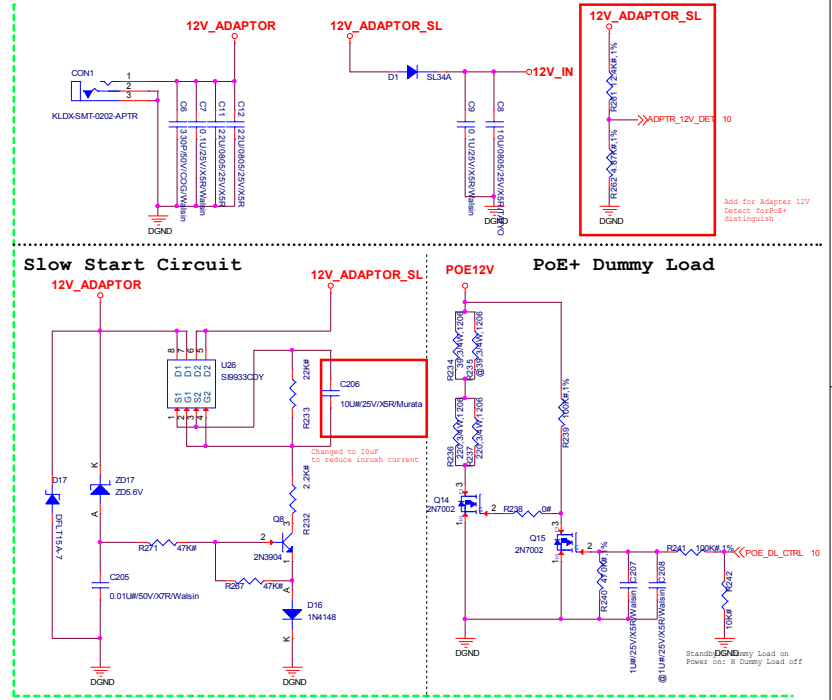

1. C15 changed from 2.2nF to 1nF (Murata GR431BR7LA102KW661)
2. C25, C26, C45, C46, C149, C150 changed from 6.8nF to 2.2nF (TDK C3225X7S3D222K*)

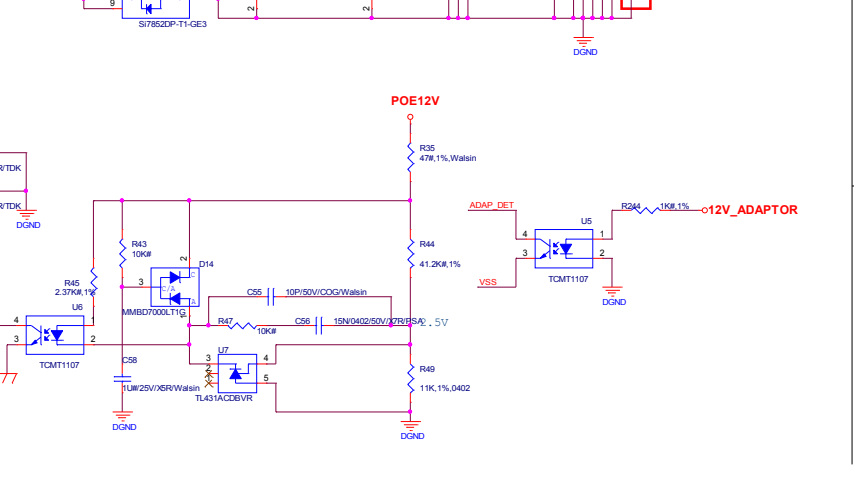
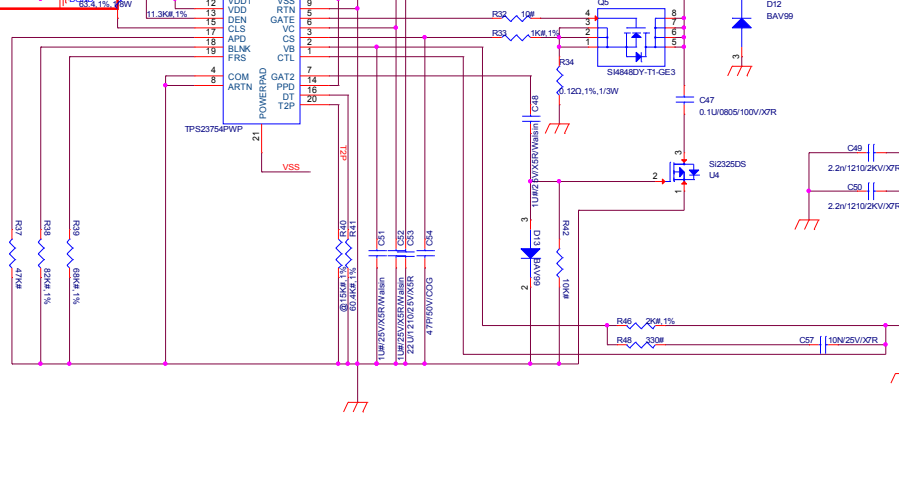
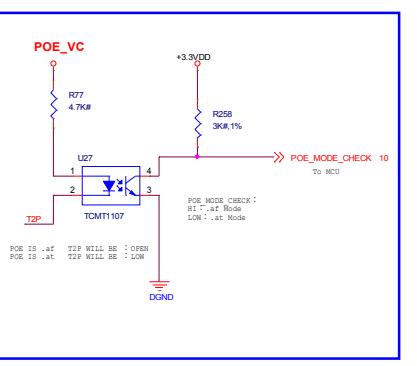

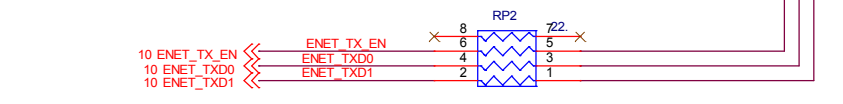
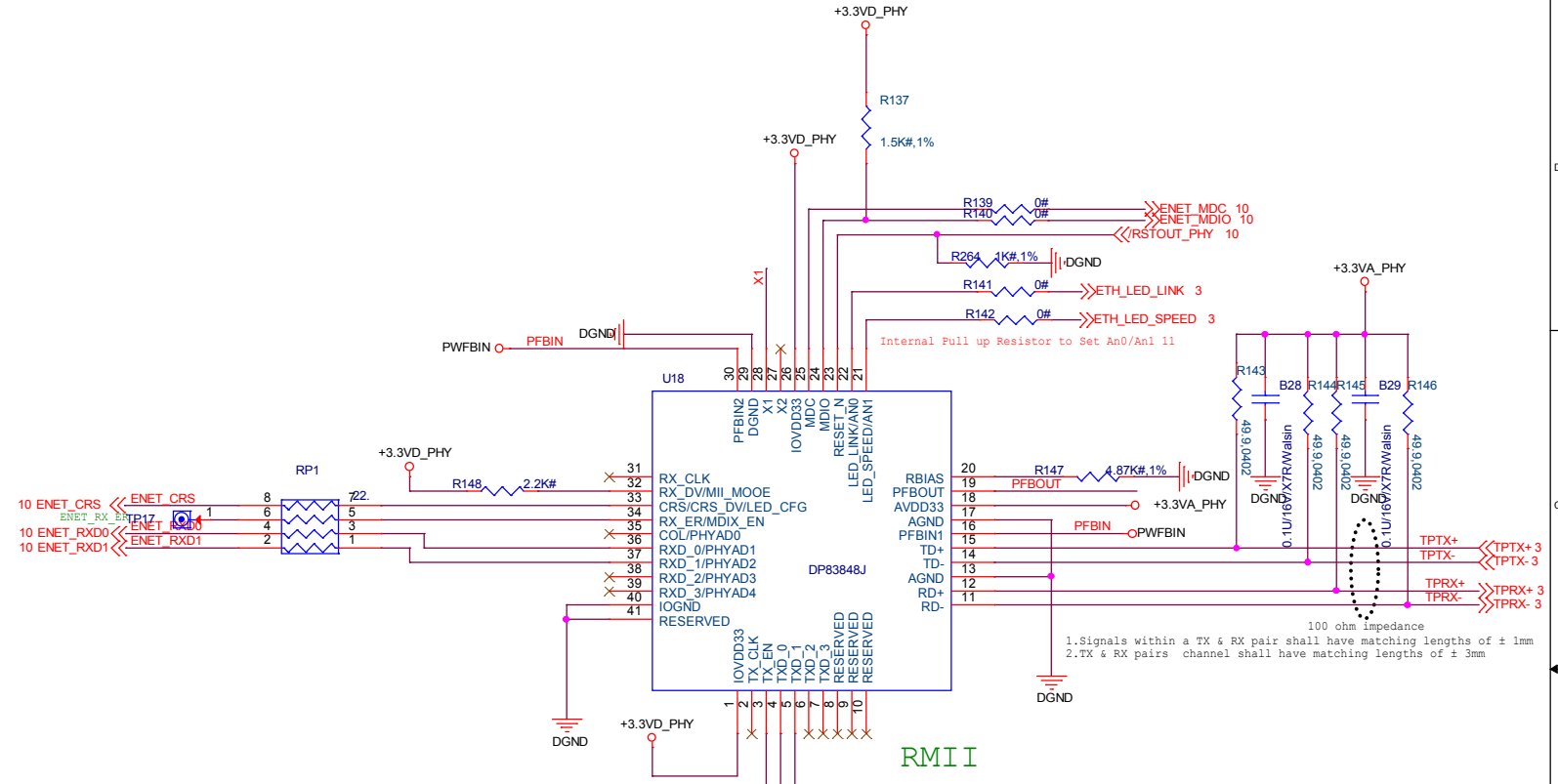
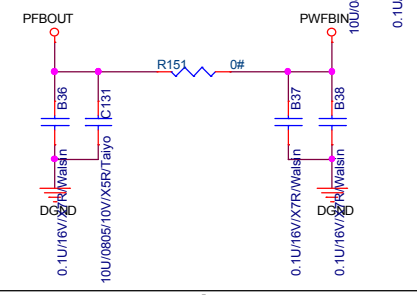
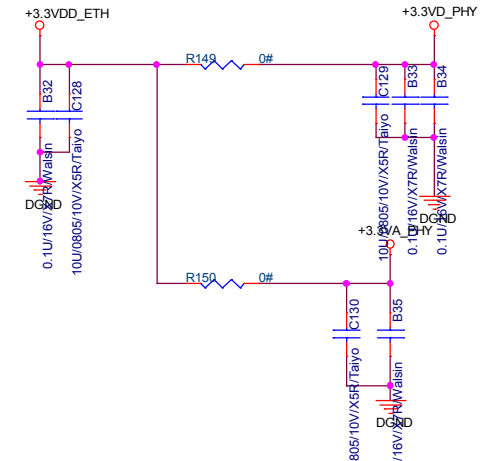
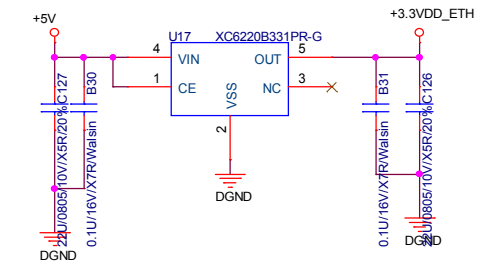
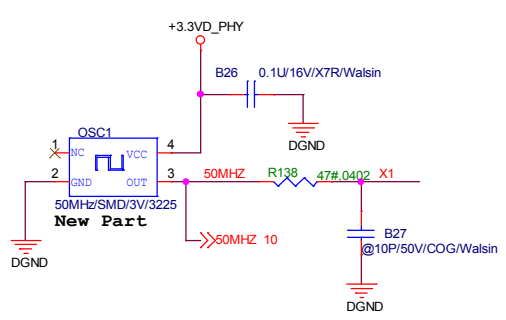

RMI1