

Connector

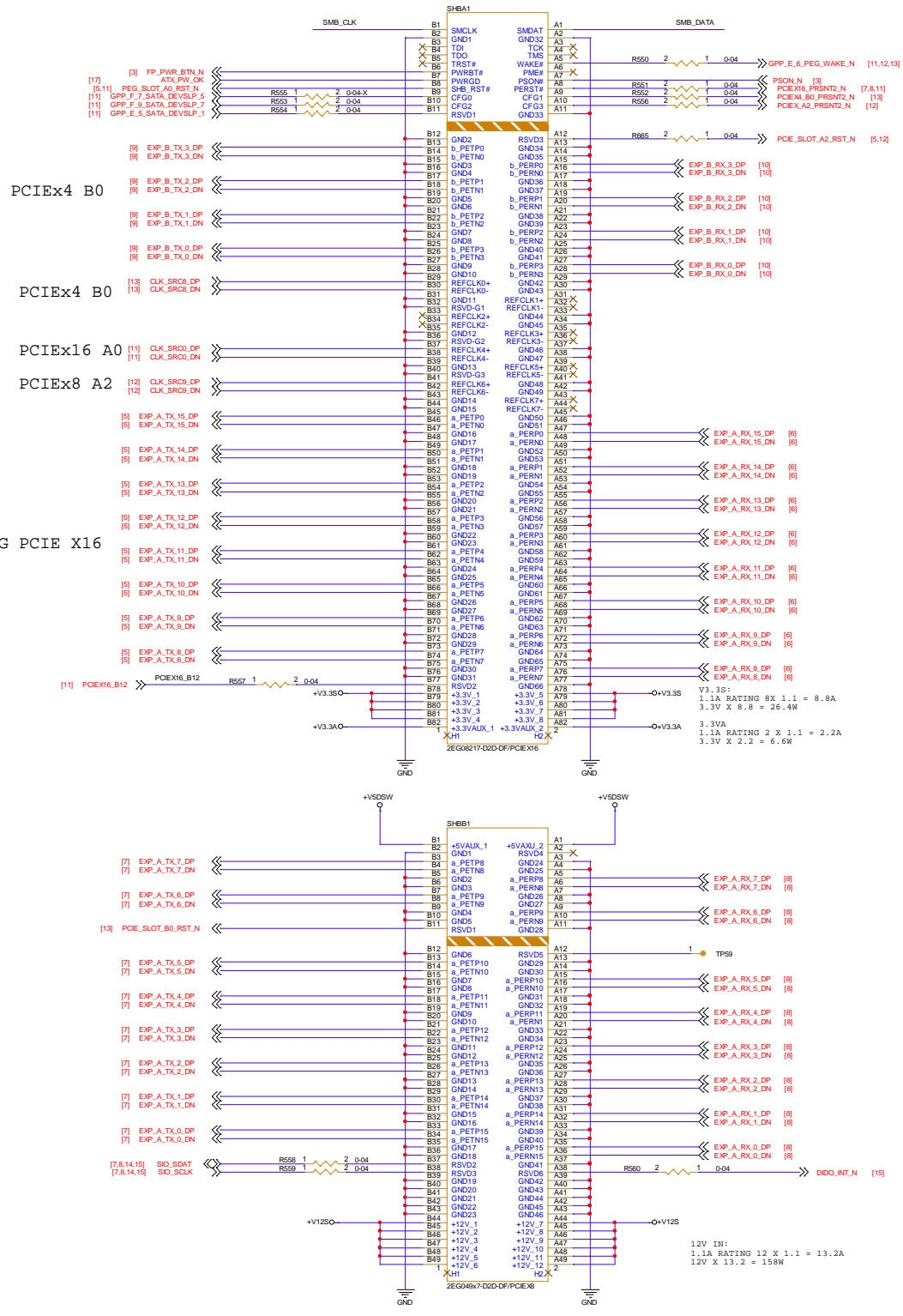

DRIVER_FUNC FOR PEG PWRK FUNCTION.

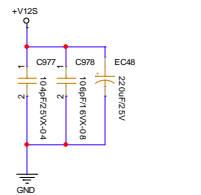

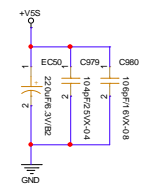
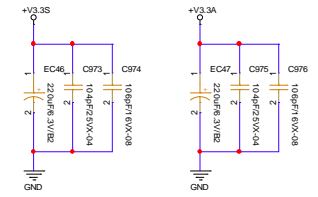
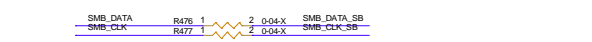
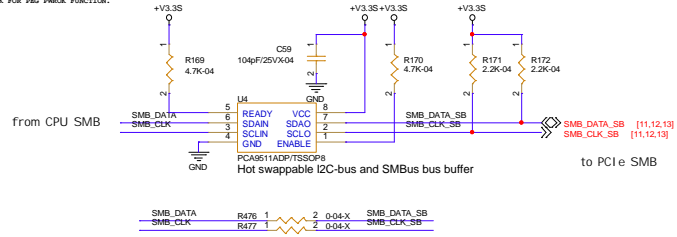
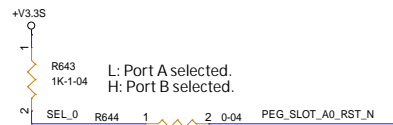
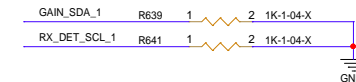
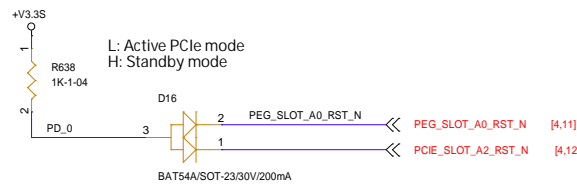
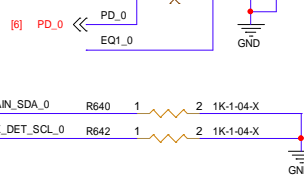
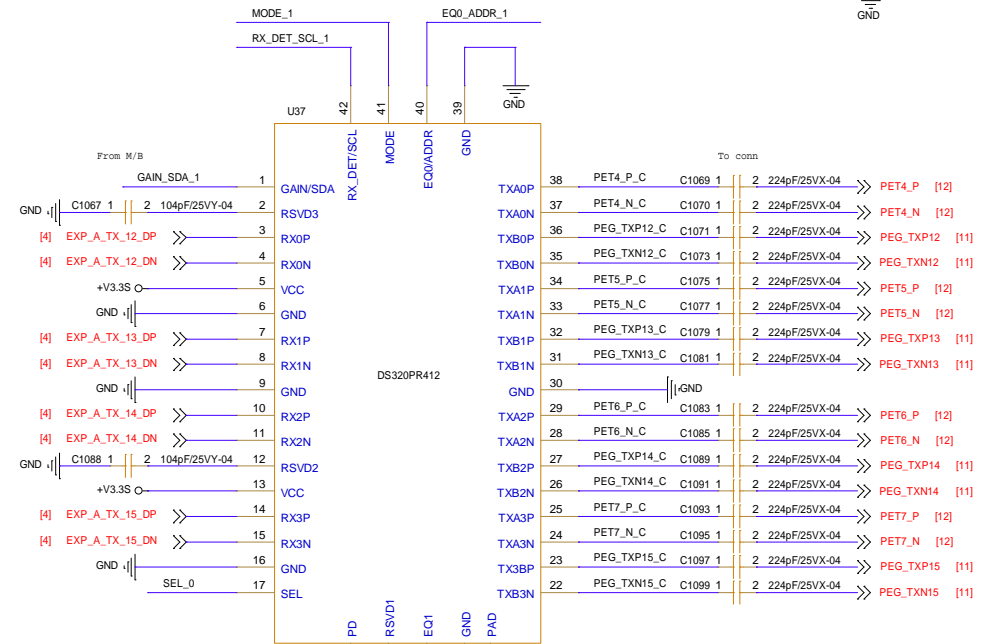
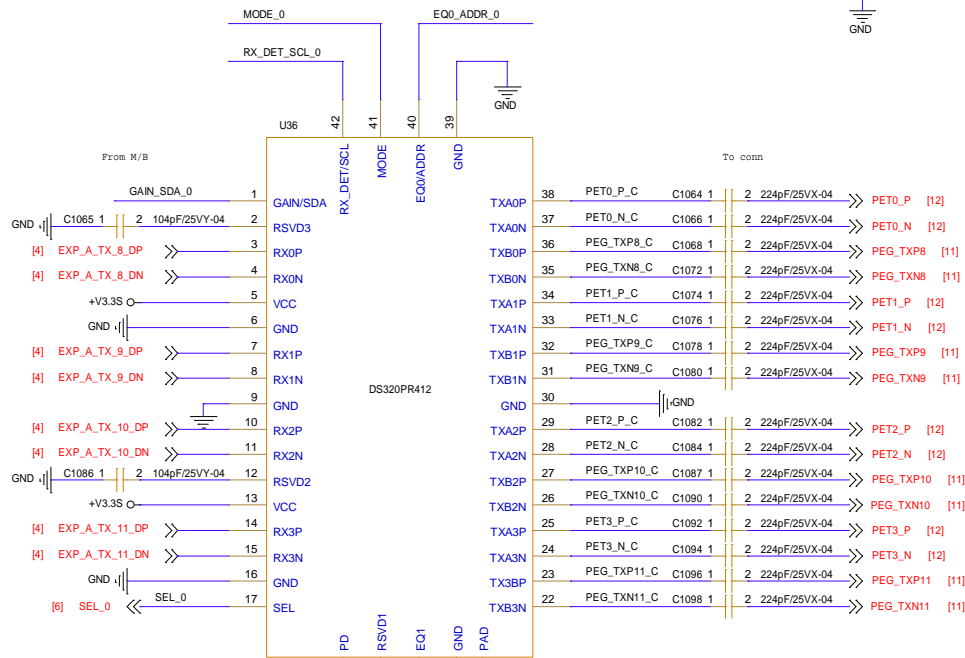
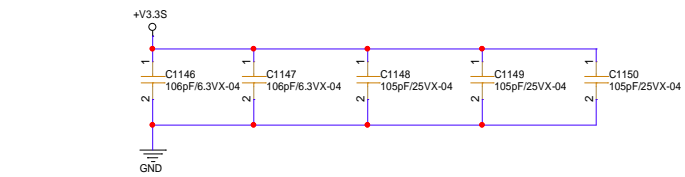

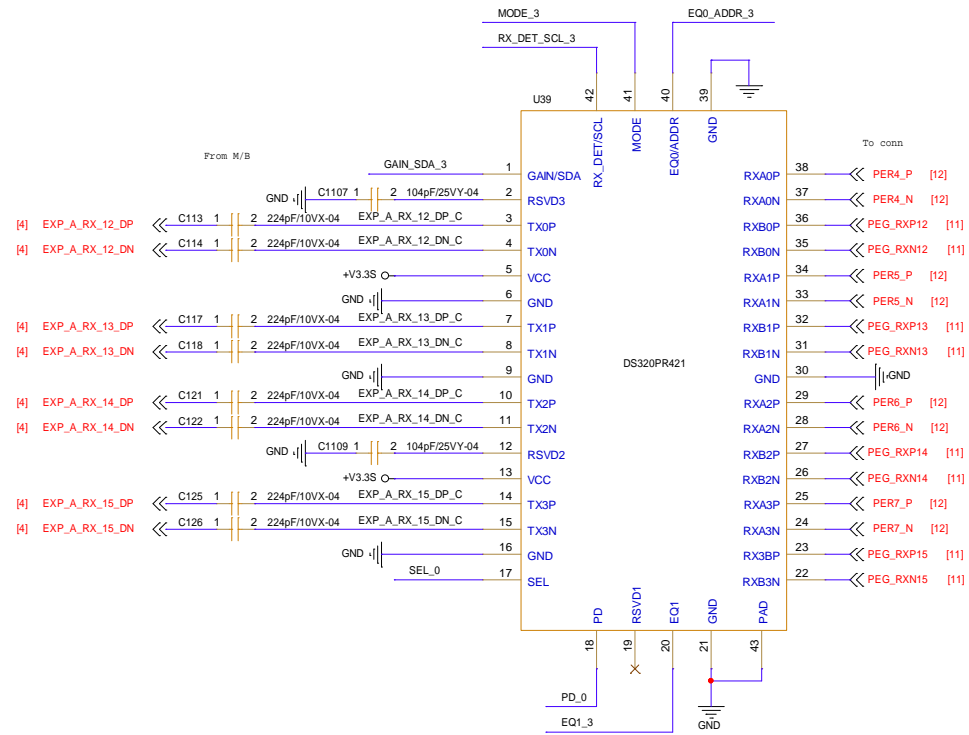
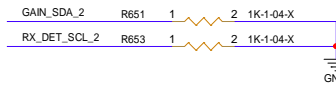
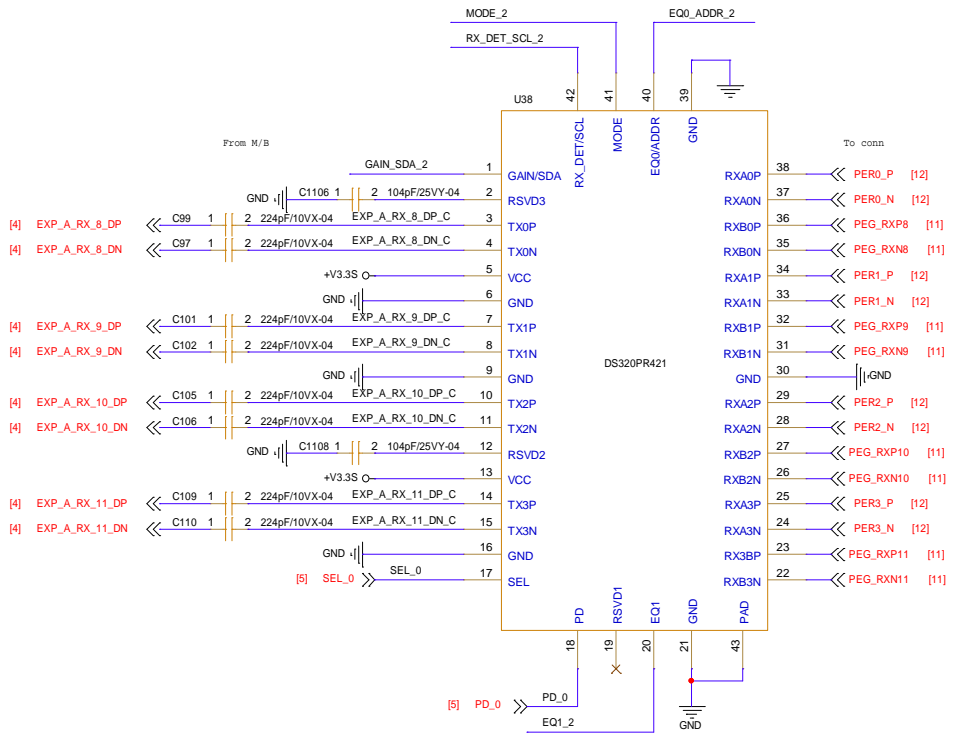
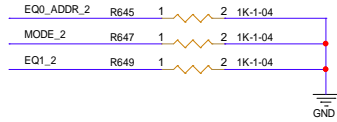
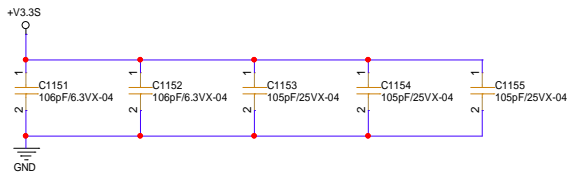

PCI-E X16

PCI-e X16 Normal Mode

X8: Lane0 ~7

X4: Lane8~11

X4: Lane12~15

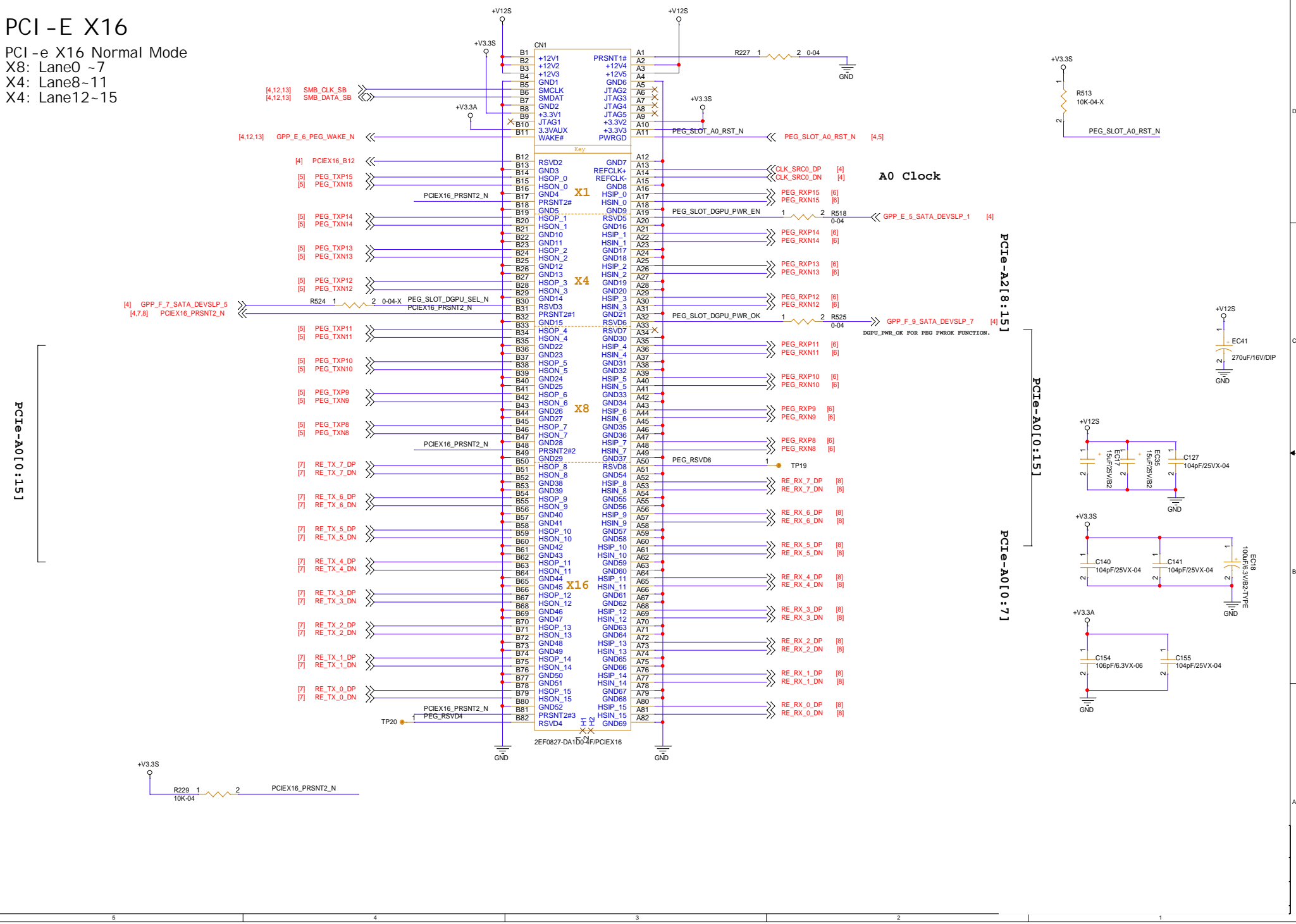

PCIe-A0[0:15]

A0 Clock

PCIe-A2[8:15]

PCIe-A0[0:15]

PCIe-A0[0:7]

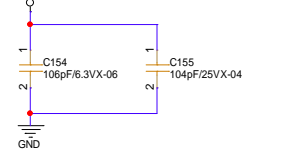
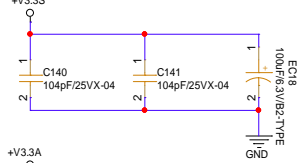
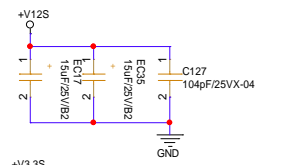
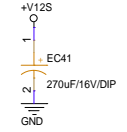

PCI-E X8

+V3.3S = 3A , +V12S = 2.1A , +V3.3A=375mA

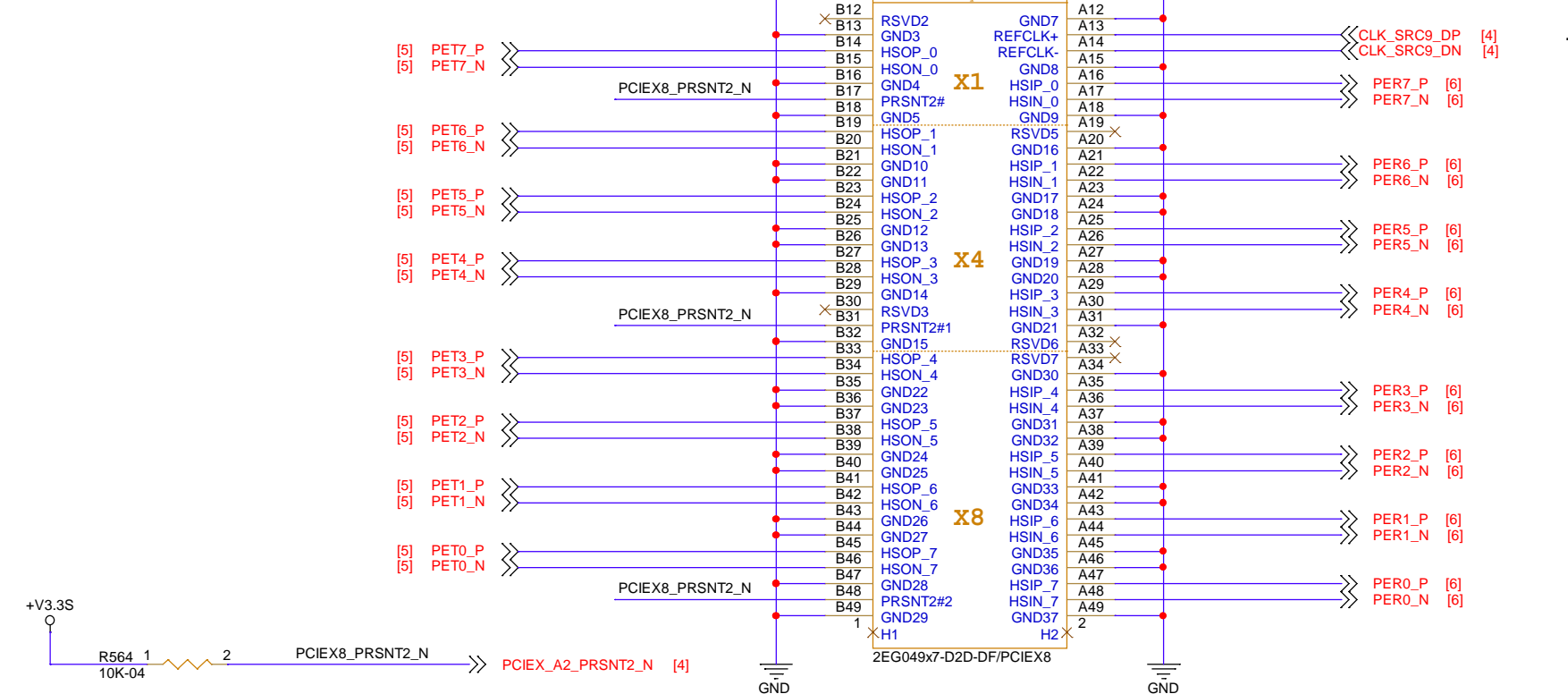
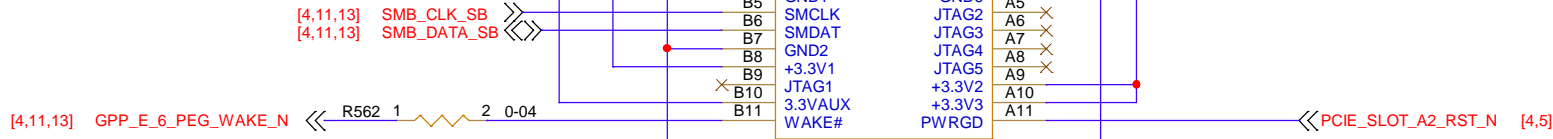

A2 Clock

PCIe-A0[0:7]

