

PD controller 1

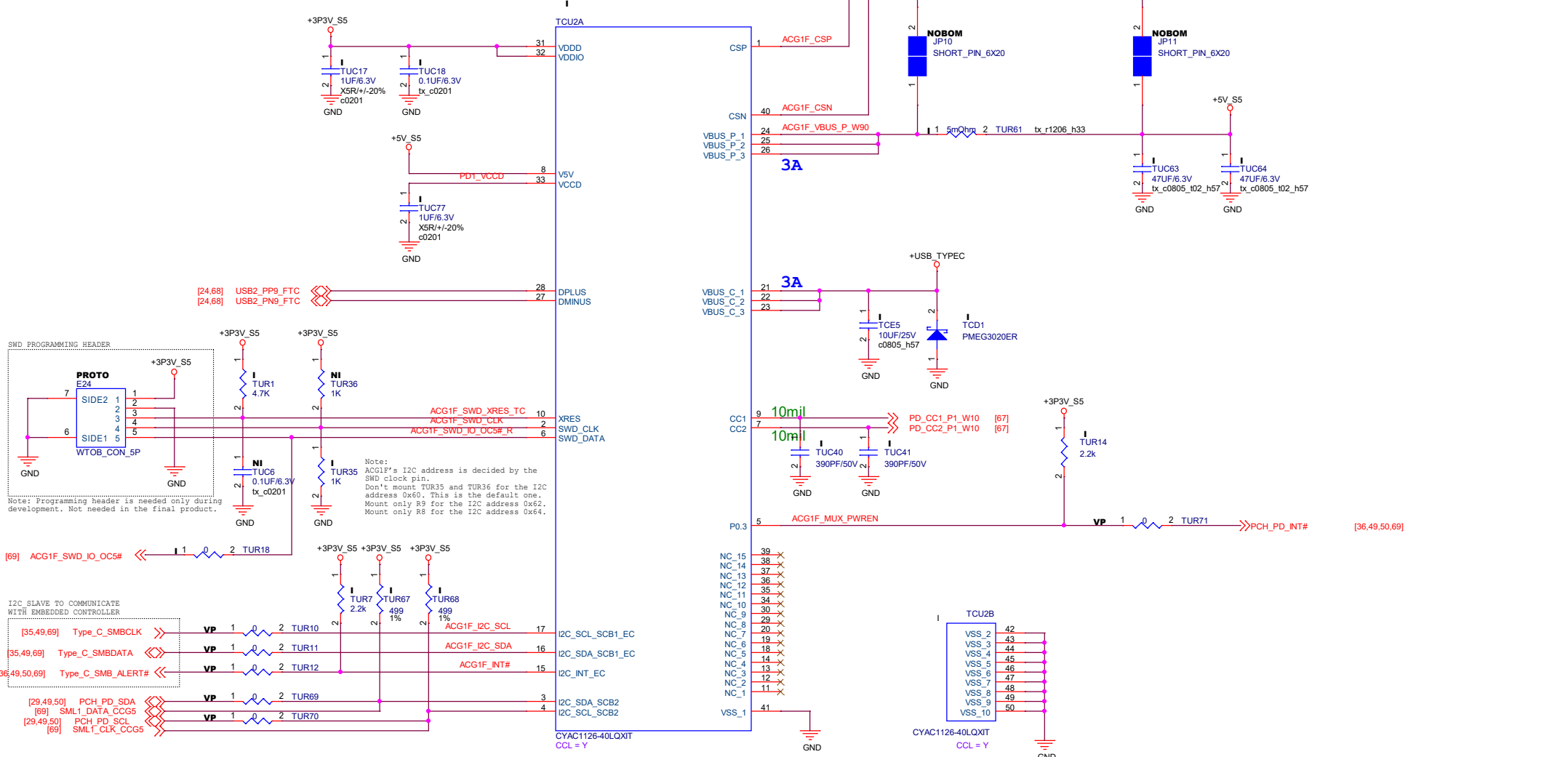

<Core Design>

		HP RESTRICTED (HP RESTRICTED SECRET)	
		<small>THIS DOCUMENT CONTAINS CONFIDENTIAL, PROPRIETARY INFORMATION THAT IS HPL DO NOT DISCLOSE TO OR DUPLICATE OTHERS EXCEPT AS AUTHORIZED BY HP.</small>	
DRAWN BY Pegatron		Title PD CONTROLLER	
Size A3	Document Number M26317-001	Rev X0	
Date: Monday, February 05, 2024		Sheet 67 of 118	

Type-C GEN2 connector 1

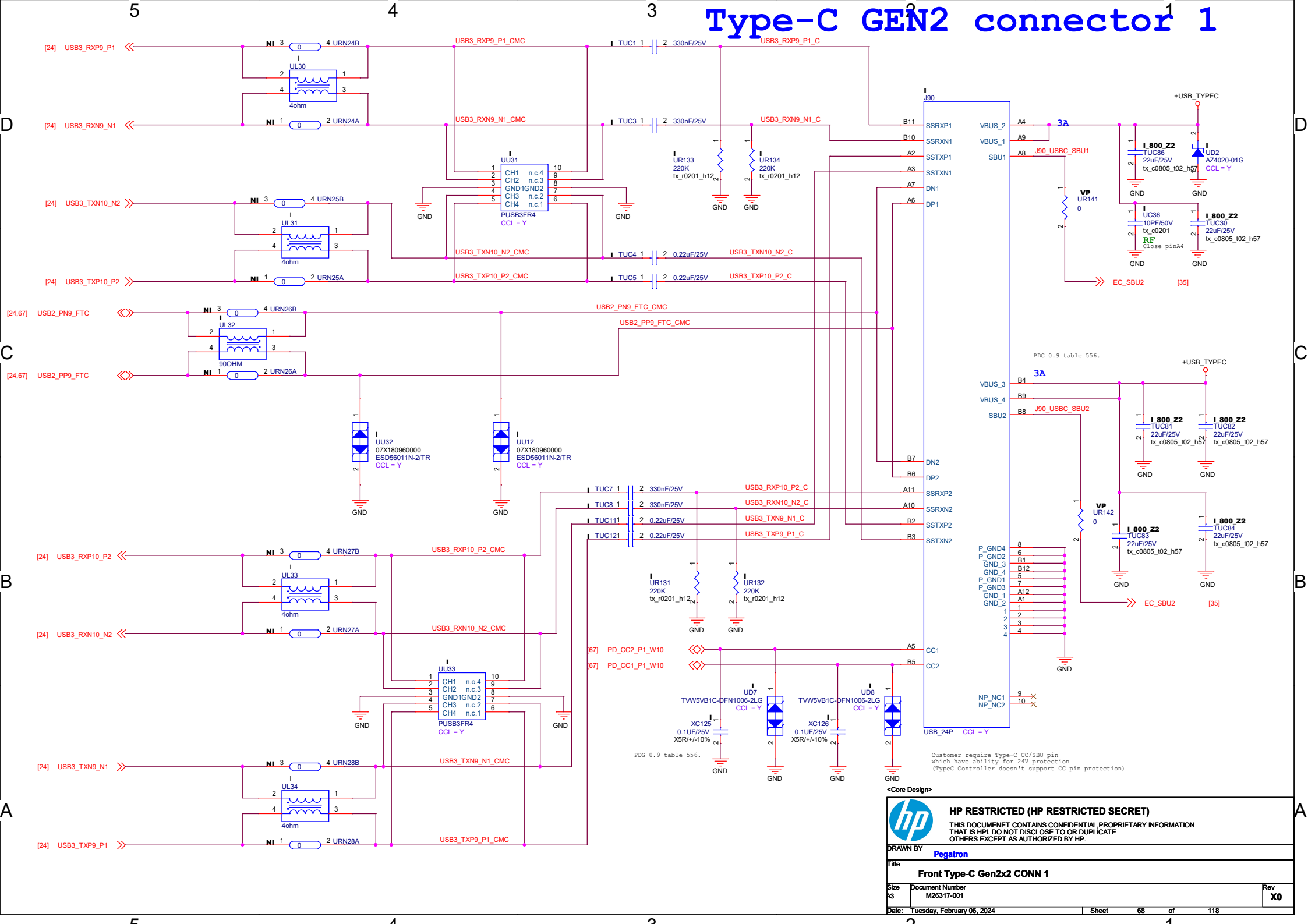

PDG 0.9 table 556.

Customer require Type-C CC/SBU pin which have ability for 24V protection (Type-C Controller doesn't support CC pin protection)

<Core Design>

		HP RESTRICTED (HP RESTRICTED SECRET) THIS DOCUMENT CONTAINS CONFIDENTIAL PROPRIETARY INFORMATION THAT IS HP's. DO NOT DISCLOSE TO OR DUPLICATE OTHERS EXCEPT AS AUTHORIZED BY HP.	
		DRAWN BY Pegatron	Title Front Type-C Gen2x2 CONN 1
Size A3	Document Number M26317-001	Date Tuesday, February 06, 2024	Sheet 68 of 118
		Rev X0	

PD controller 2

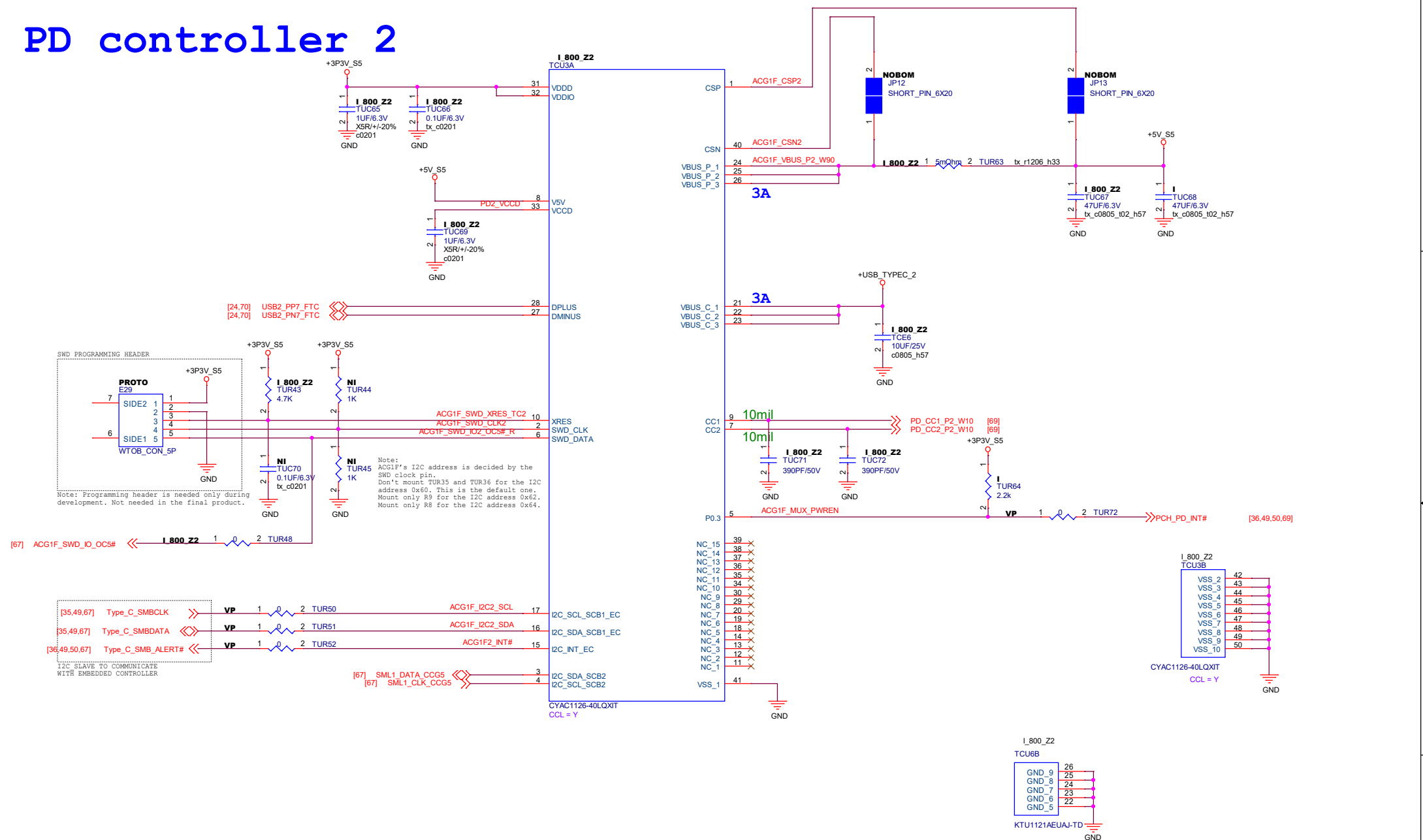

<Core Design>

hp **HP RESTRICTED (HP RESTRICTED SECRET)**

THIS DOCUMENT CONTAINS CONFIDENTIAL, PROPRIETARY INFORMATION THAT IS HPL DO NOT DISCLOSE TO OR DUPLICATE OTHERS EXCEPT AS AUTHORIZED BY HP.

DRAWN BY **Pegatron**

Title **Front Type-C PD 2**

Size **A3** Document Number **M26317-001** Rev **X0**

Date: **Monday, February 05, 2024** Sheet **69** of **118**

Type-C GEN2 connector 2

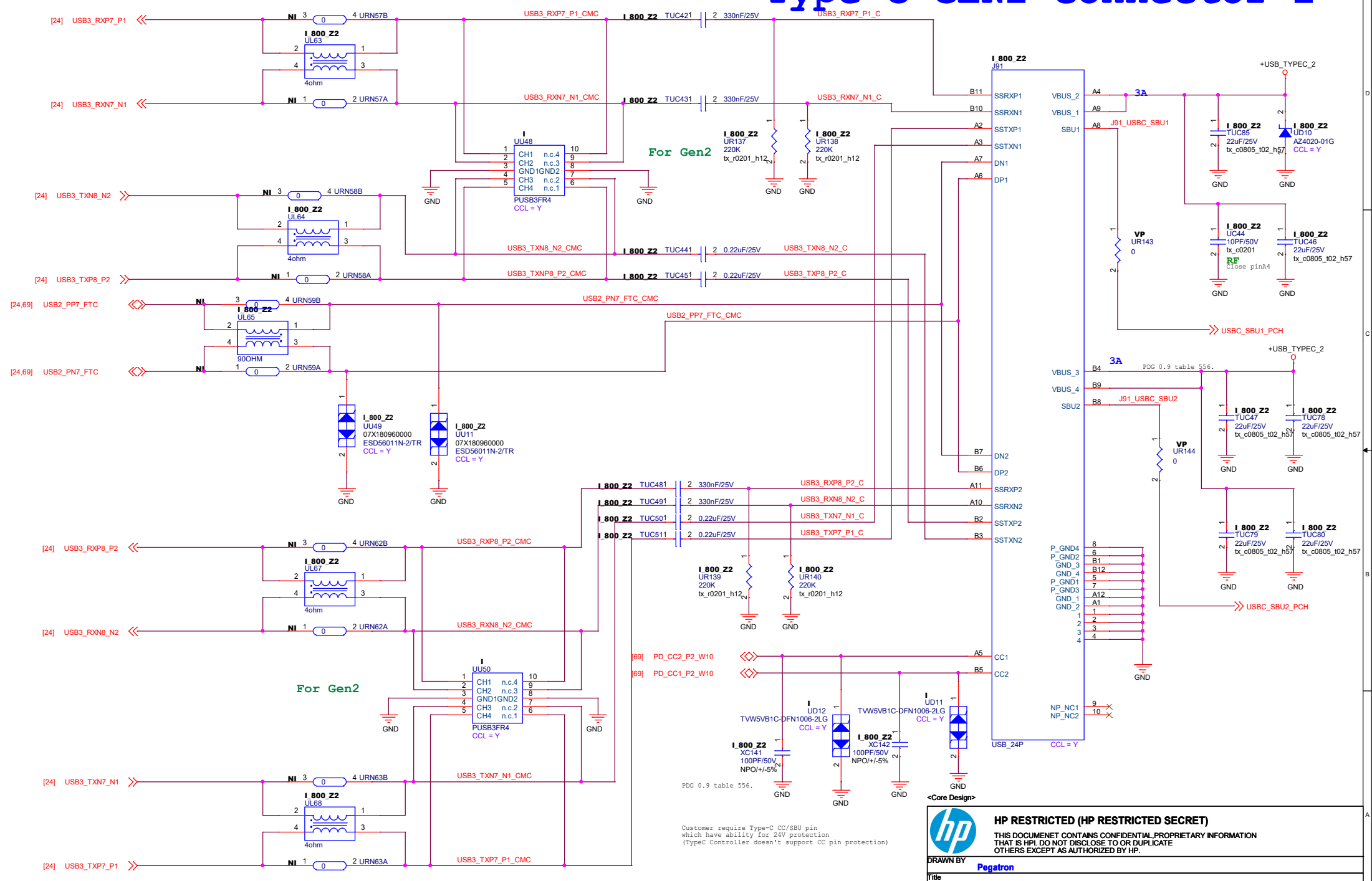

For Gen2

For Gen2

hp **HP RESTRICTED (HP RESTRICTED SECRET)**

THIS DOCUMENT CONTAINS CONFIDENTIAL, PROPRIETARY INFORMATION THAT IS HPL DO NOT DISCLOSE TO OR DUPLICATE OTHERS EXCEPT AS AUTHORIZED BY HP.

DRAWN BY: **Pegatron**

Title: **Front Type-C Gen2x2 CONN 2**

Size: A3	Document Number: M26317-001	Rev: X0
Date: Tuesday, February 06, 2024	Sheet: 70 of 118	