

Block Diagram

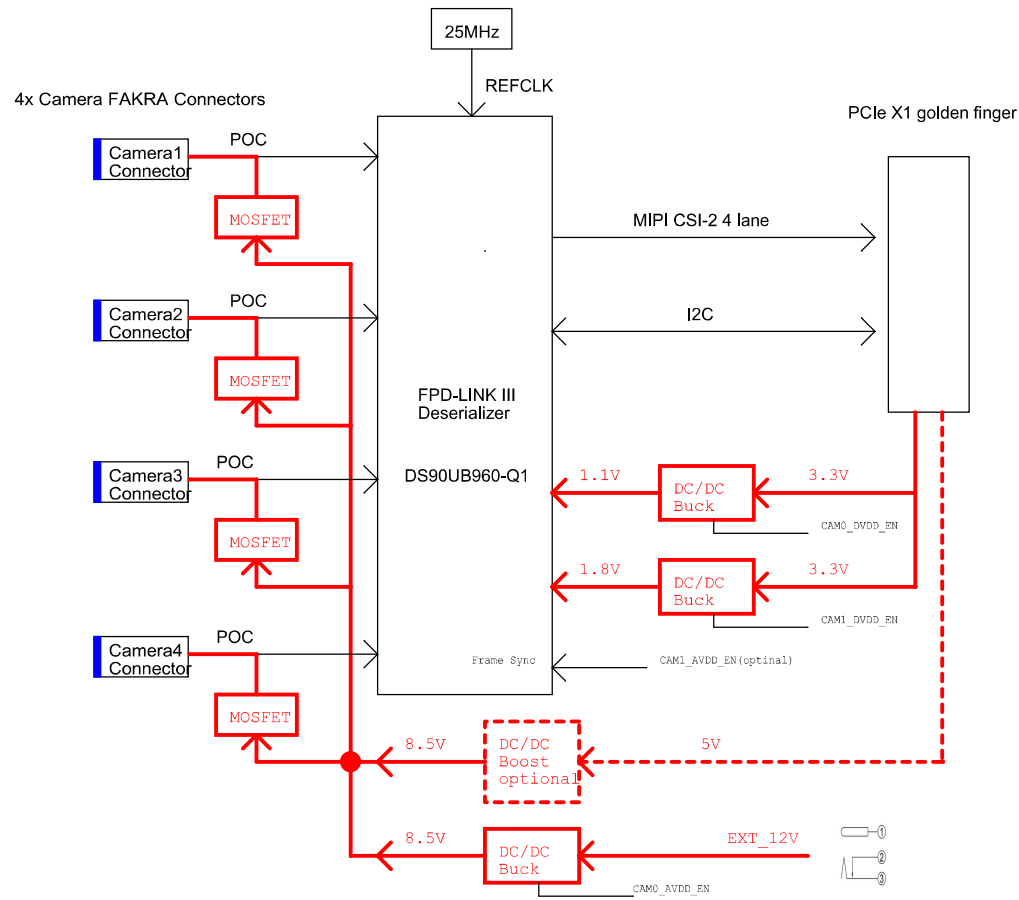



Power -1

1.5MHz, 1A sync Buck

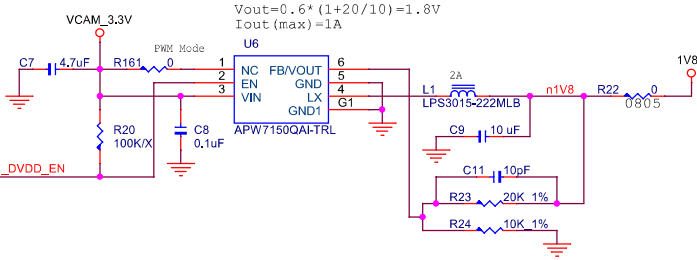

1.5MHz, 1A sync Buck

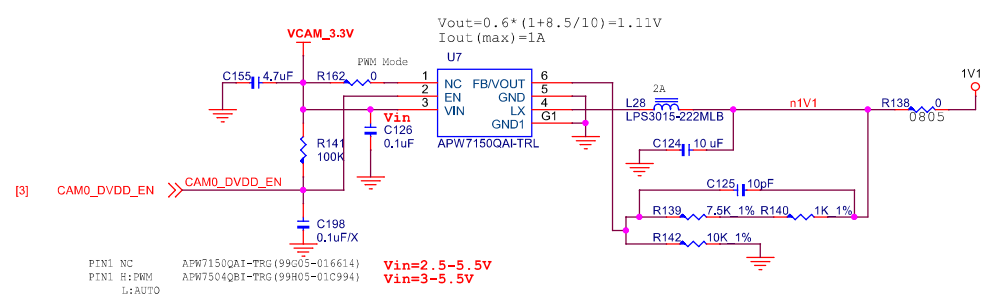

Buck 5V/8.5V 5A

$V_{out} = 0.8 * (1 + 82/15) = 5.17V$
 $V_{out} = 0.8 * (1 + 82/8.36) = 8.64V$
 $I_{out(max)} = 5A$

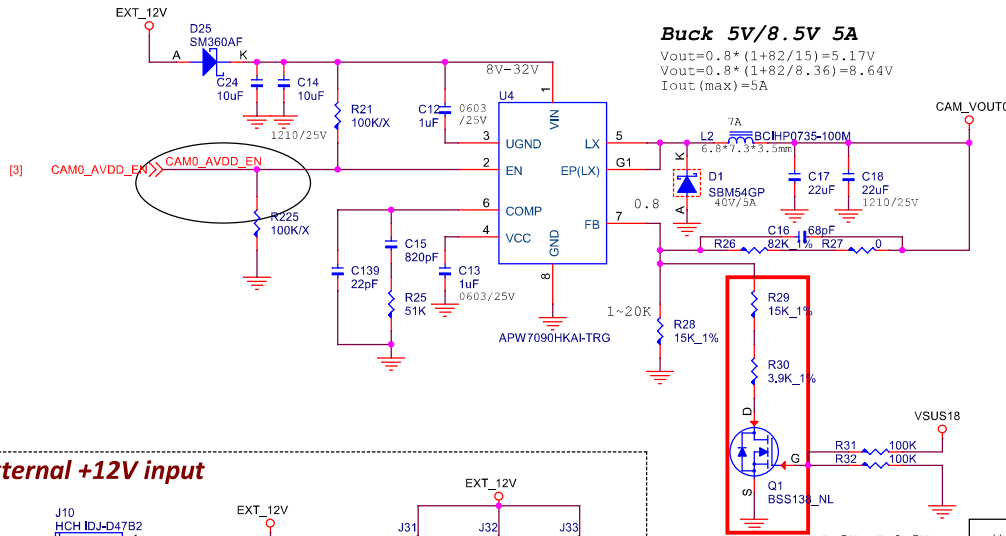

Quad FPD-Link III Deserializer Hub (DS90UB960-Q1)

VDD11	1.1V, <310mA
VDD18	1.8V, <340mA
VDDIO	1.8V, <3mA

Power On Sequence: VDD18&VDDIO-->VDD11-->PDB

NOTE CSI-2 TX data rate = 1.664 Gbps (4lane)
 4 x FPD-link III RX inputs (4.16Gbps)
 <Non-replicate Mode>
 Default registers

CAMERA Module
 8.5V/160mA/1pcs (720P)

POC_VOUT0

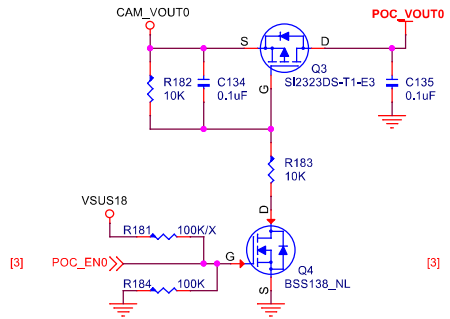

POC_VOUT1

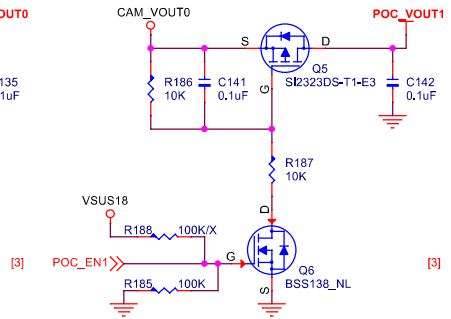

POC_VOUT2

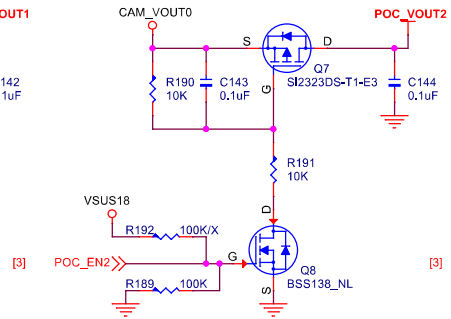

POC_VOUT3

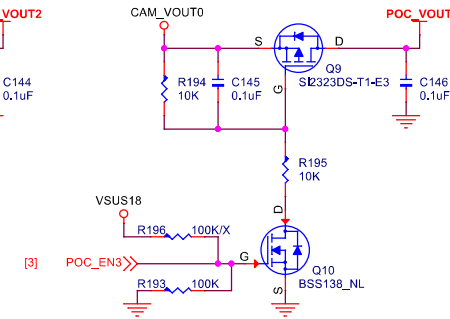

Quad FPD-Link III Deserializer Hub with MIPI CSI2 output (DS90UB960-Q1)

