

Title		<Title>
Size	Document Number	FPGA Banks 14 and 15
Date:	Thursday, October 03, 2019	Sheet 3 of 8
Rev		0

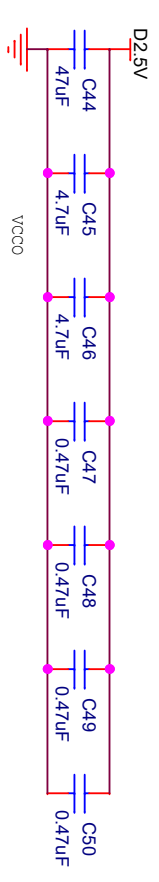

Note: RGMII_TX nets must be equal length to RGMII_GTXCLK Place near FPGA

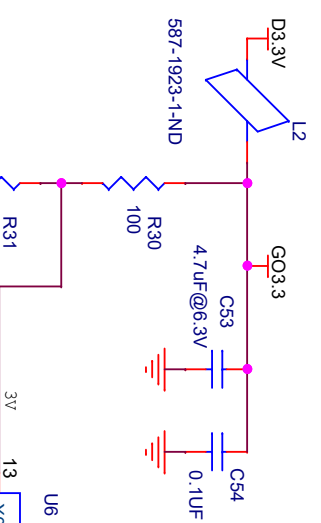
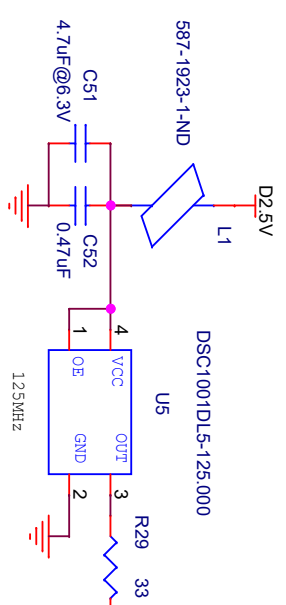
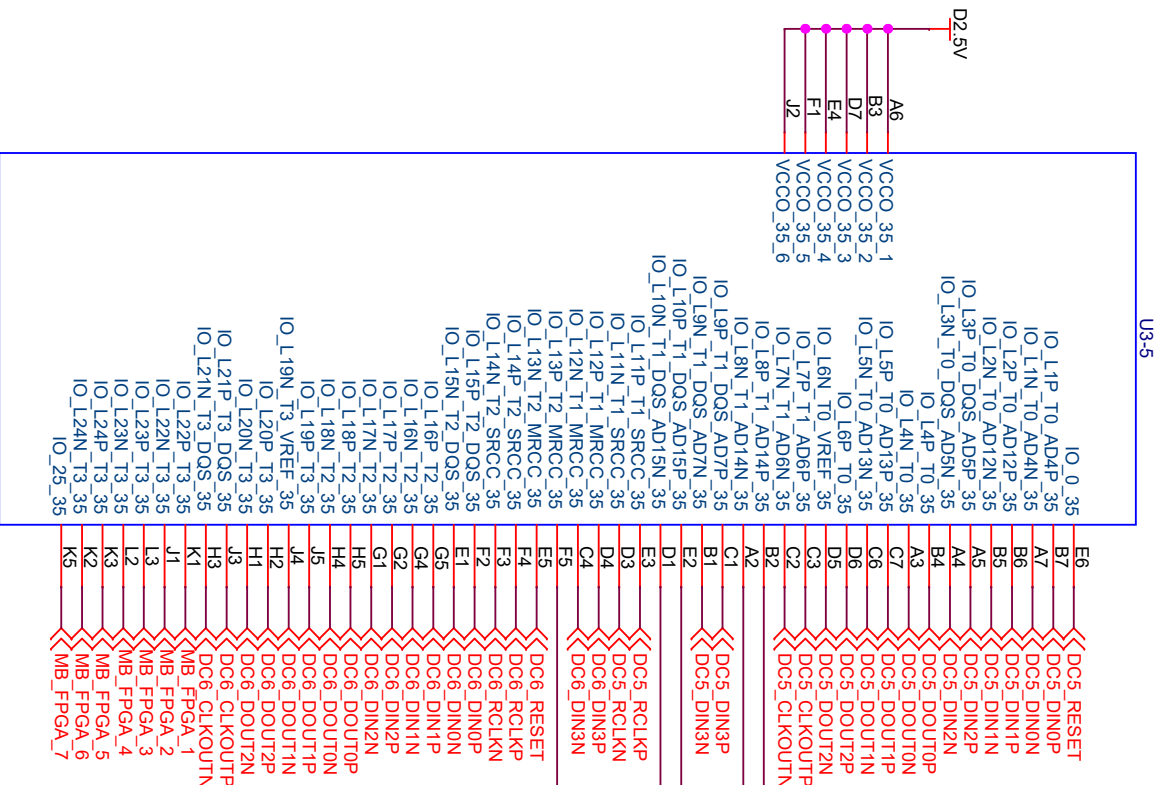
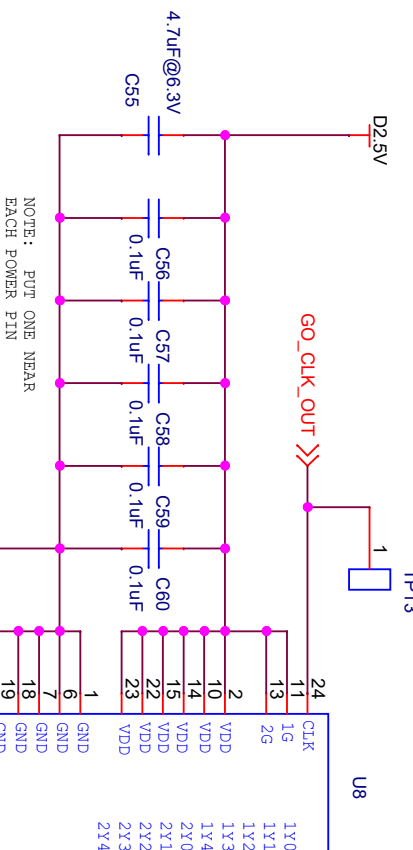
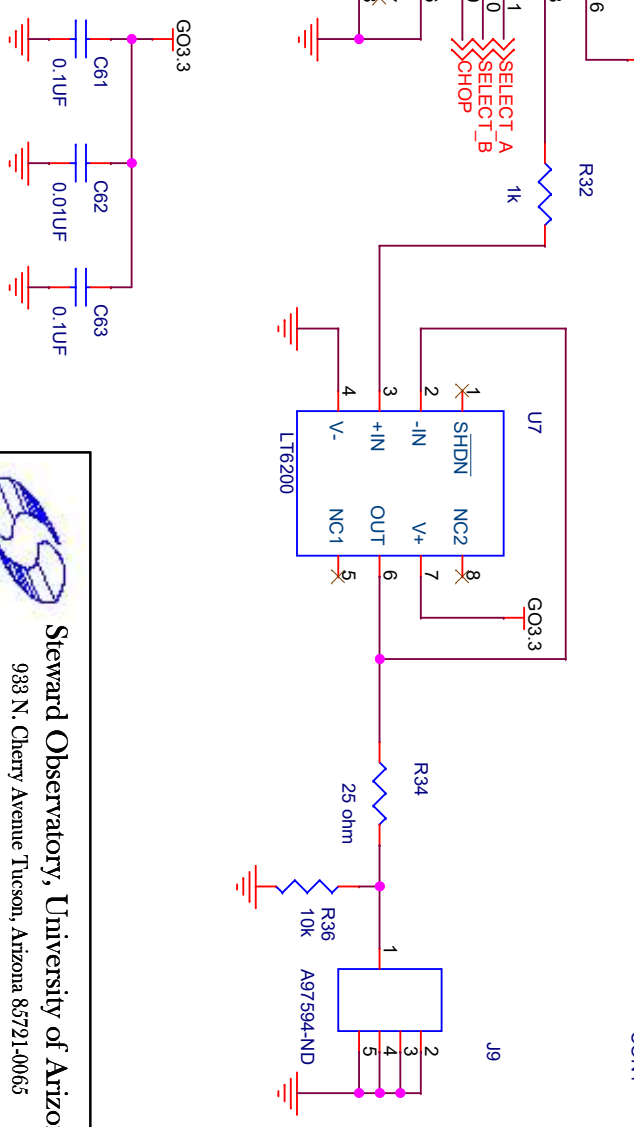
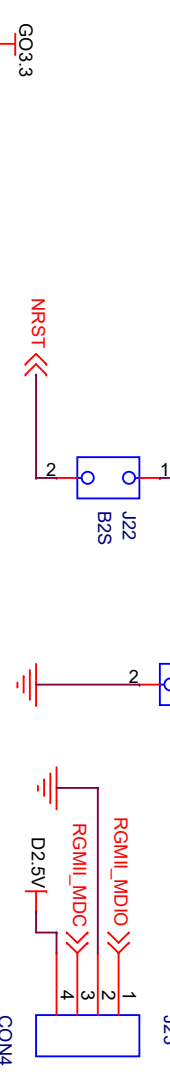
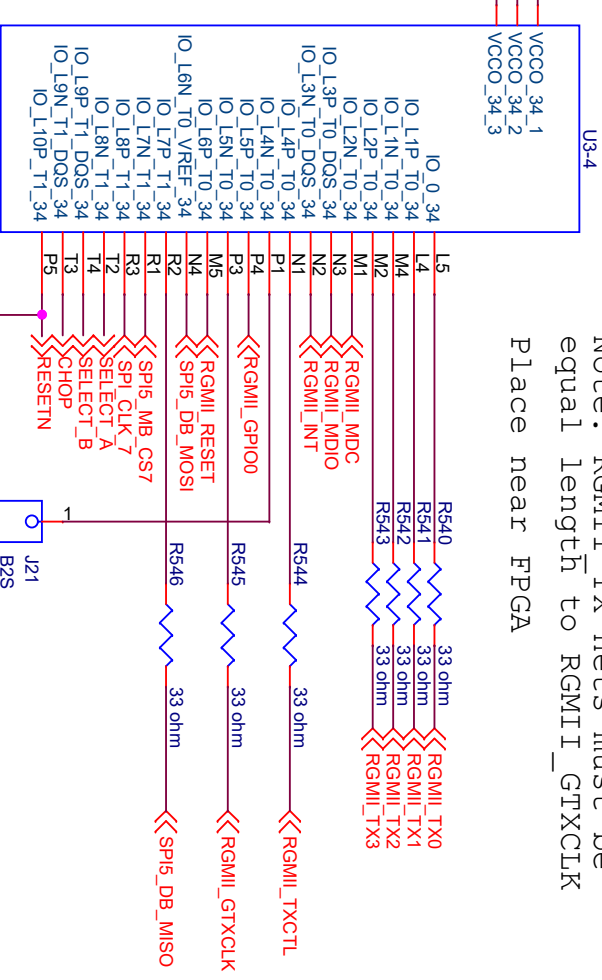

NOTE: PUT ONE NEAR EACH POWER PIN

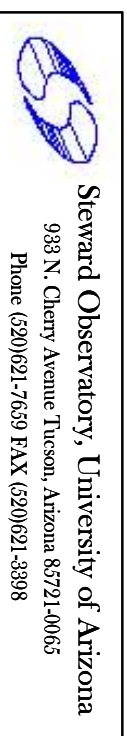

Steward Observatory, University of Arizona
983 N. Cherry Avenue Tucson, Arizona 85721-0065
Phone (520)621-7659 FAX (520)621-3398

MAPS MOTHERBOARD

Title	Document Number	Rev
Size	FPGA Banks 34 and 35	0
Date:	Thursday, October 03, 2019	Sheet
		4 of 8

If Vertical is desired, use Pulse Electronics JXD2--0015NL

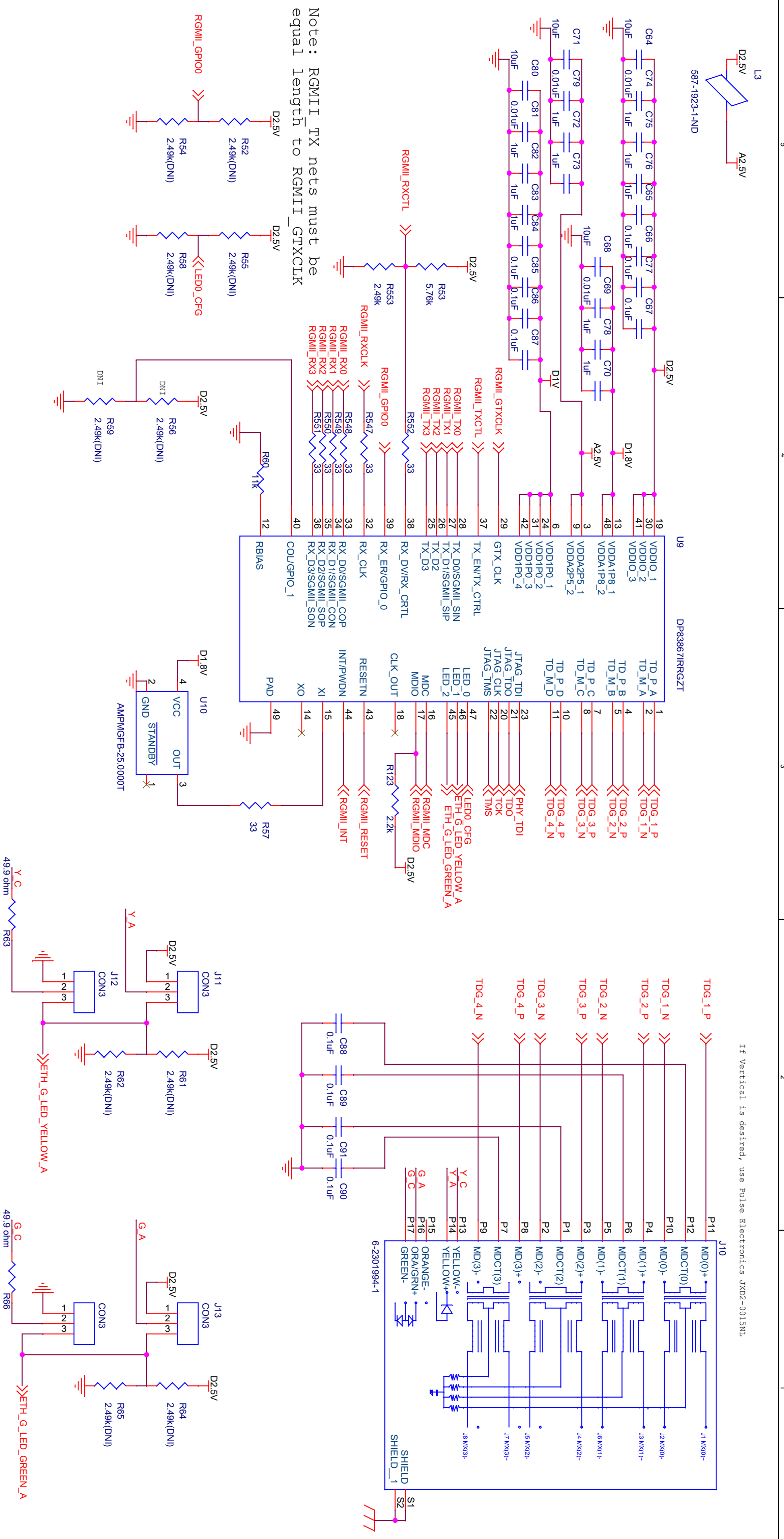

Note: RGMII TX nets must be equal length to RGMII GTXCLK

Note: Make all RGMII_RX* traces equal length

Steward Observatory, University of Arizona
 933 N. Cherry Avenue Tucson, Arizona 85721-0065
 Phone (520)621-7659 FAX (520)621-3398

Title		MAPS MOTHERBOARD	
Size	Document Number	GBEthernet Interface	
B		Sheet	5 of 8
Date:	Thursday, October 03, 2019	Rev	0