

Type : Bandpass
 Response : Bessel
 Order : 8
 Number of Stages : 4

Filter Design Report

Design : Bandpass Filter - 8th order Bessel
 Design ID: 12

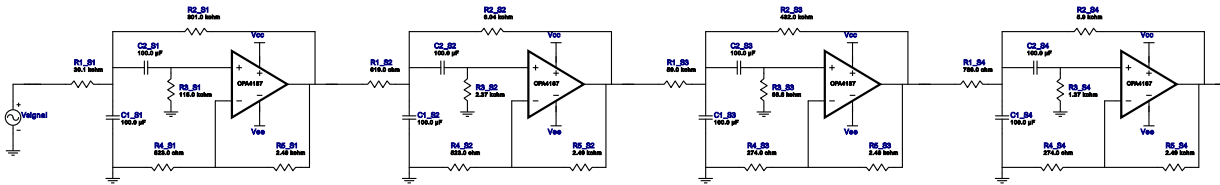

Electrical BOM

#	Name	Manufacturer	Part Number	Properties	Qty
1.	A1_S1	Texas Instruments Inc.	OPA4187	GbwTyp= 0.55MHz VccMax= 36V VccMin= 4.5V	1
2.	A1_S2	Texas Instruments Inc.	OPA4187	GbwTyp= 0.55MHz VccMax= 36V VccMin= 4.5V	1
3.	A1_S3	Texas Instruments Inc.	OPA4187	GbwTyp= 0.55MHz VccMax= 36V VccMin= 4.5V	1
4.	A1_S4	Texas Instruments Inc.	OPA4187	GbwTyp= 0.55MHz VccMax= 36V VccMin= 4.5V	1
5.	C1_S1	Generic	Ideal	Cap= 100.0 uF Tolerance= 2.0 %	1
6.	C1_S2	Generic	Ideal	Cap= 100.0 uF Tolerance= 2.0 %	1
7.	C1_S3	Generic	Ideal	Cap= 100.0 uF Tolerance= 2.0 %	1
8.	C1_S4	Generic	Ideal	Cap= 100.0 uF Tolerance= 2.0 %	1
9.	C2_S1	Generic	Ideal	Cap= 100.0 uF Tolerance= 2.0 %	1
10.	C2_S2	Generic	Ideal	Cap= 100.0 uF Tolerance= 2.0 %	1
11.	C2_S3	Generic	Ideal	Cap= 100.0 uF Tolerance= 2.0 %	1
12.	C2_S4	Generic	Ideal	Cap= 100.0 uF Tolerance= 2.0 %	1
13.	R1_S1	Generic	Ideal	Res= 30100.0ohm Tolerance= 1%	1
14.	R1_S2	Generic	Ideal	Res= 619.0ohm Tolerance= 1%	1
15.	R1_S3	Generic	Ideal	Res= 59000.0ohm Tolerance= 1%	1
16.	R1_S4	Generic	Ideal	Res= 768.0ohm Tolerance= 1%	1
17.	R2_S1	Generic	Ideal	Res= 301000.0ohm Tolerance= 1%	1

#	Name	Manufacturer	Part Number	Properties	Qty
18.	R2_S2	Generic	Ideal	Res= 6040.0ohm Tolerance= 1%	1
19.	R2_S3	Generic	Ideal	Res= 432000.0ohm Tolerance= 1%	1
20.	R2_S4	Generic	Ideal	Res= 5900.0ohm Tolerance= 1%	1
21.	R3_S1	Generic	Ideal	Res= 115000.0ohm Tolerance= 1%	1
22.	R3_S2	Generic	Ideal	Res= 2370.0ohm Tolerance= 1%	1
23.	R3_S3	Generic	Ideal	Res= 86600.0ohm Tolerance= 1%	1
24.	R3_S4	Generic	Ideal	Res= 1370.0ohm Tolerance= 1%	1
25.	R4_S1	Generic	Ideal	Res= 523.0ohm Tolerance= 1%	1
26.	R4_S2	Generic	Ideal	Res= 523.0ohm Tolerance= 1%	1
27.	R4_S3	Generic	Ideal	Res= 274.0ohm Tolerance= 1%	1
28.	R4_S4	Generic	Ideal	Res= 274.0ohm Tolerance= 1%	1
29.	R5_S1	Generic	Ideal	Res= 2490.0ohm Tolerance= 1%	1
30.	R5_S2	Generic	Ideal	Res= 2490.0ohm Tolerance= 1%	1
31.	R5_S3	Generic	Ideal	Res= 2490.0ohm Tolerance= 1%	1
32.	R5_S4	Generic	Ideal	Res= 2490.0ohm Tolerance= 1%	1

Sensitivity Analysis

#	Name	Series	Tolerance
1.	Cap	E48	2%
2.	Res	E96	1%

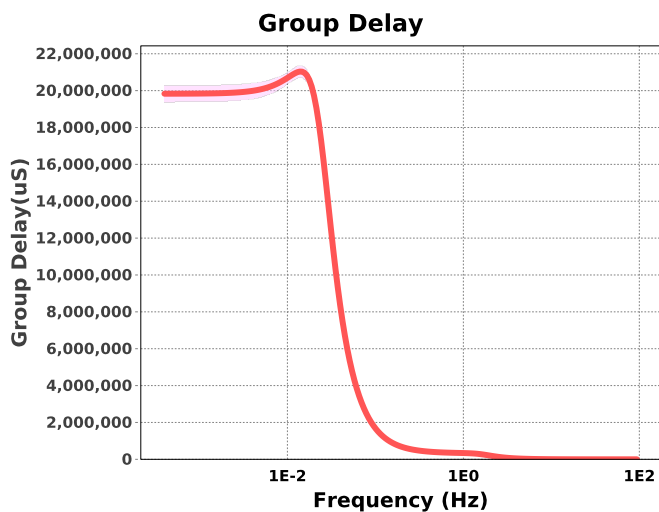
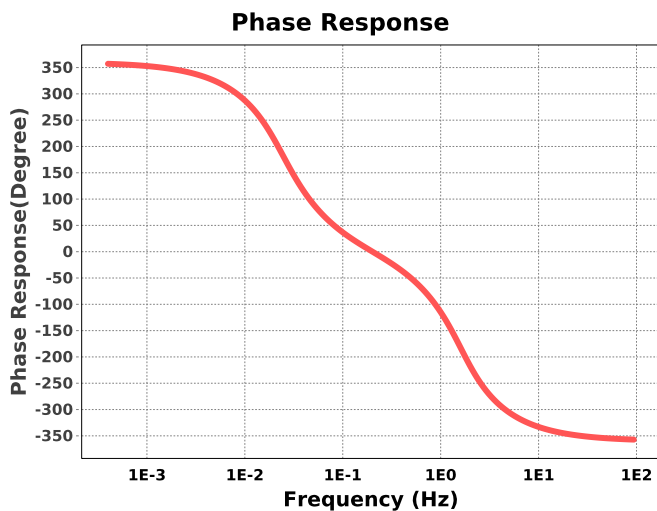
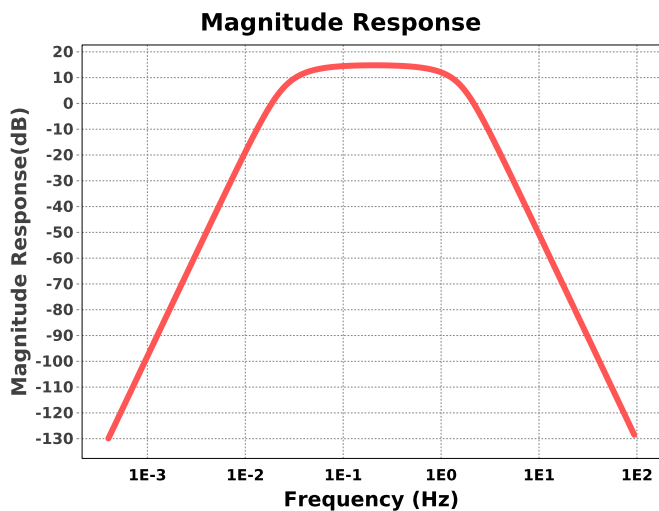

Design Inputs

#	Name	Value	Description
1.	FilterType	bandpass	
2.	FilterResponse	Bessel	
3.	FilterOrder	8.0	
4.	FilterTopology	Sallen-Key	
5.	NumberOfStages	4.0	
6.	CenterFrequency	200.0 m	
7.	StopbandAttenuation	-65.946	
8.	PassbandBandwidth	1.0	
9.	StopbandBandwidth	10.0	
10.	Gain	5.623	
11.	DualSupply	+/-5.00 V	Power supply(s) to active chips
12.	ResistorTolerance	E96	Resistor series - 1% Passive resistor tolerance
13.	CapacitorTolerance	E48	Capacitor series - 2% Passive capacitor tolerance

Design Assistance

1. **OPA4187** Product Folder : <http://www.ti.com/product/OPA4187> : contains the data sheet and other resources.

Filter Stage :1

Cutoff Frequency 28.372 mHz
 Min GBW Req'd 8.592 Hz
 Stage Gain 5.761 V/V
 Stage Q 512.303 m
 Stage Topology Sallen-Key

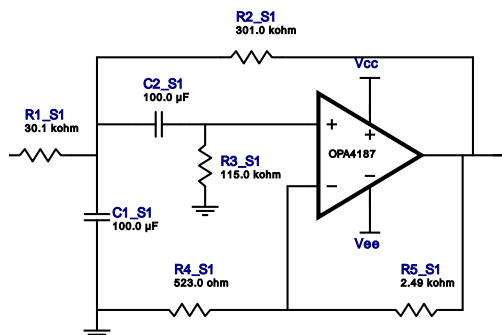

Electrical BOM

#	Name	Manufacturer	Part Number	Properties	Qty
1.	A1_S1	Texas Instruments Inc.	OPA4187	GbwTyp= 0.55MHz VccMax= 36V VccMin= 4.5V	1
2.	C1_S1	Generic	Ideal	Cap= 100.0 uF Tolerance= 2.0 %	1
3.	C2_S1	Generic	Ideal	Cap= 100.0 uF Tolerance= 2.0 %	1
4.	R1_S1	Generic	Ideal	Res= 30100.0ohm Tolerance= 1%	1
5.	R2_S1	Generic	Ideal	Res= 301000.0ohm Tolerance= 1%	1
6.	R3_S1	Generic	Ideal	Res= 115000.0ohm Tolerance= 1%	1
7.	R4_S1	Generic	Ideal	Res= 523.0ohm Tolerance= 1%	1
8.	R5_S1	Generic	Ideal	Res= 2490.0ohm Tolerance= 1%	1

Filter Stage :2

Cutoff Frequency 1.38 Hz
 Min GBW Req'd 418.366 Hz
 Stage Gain 5.761 V/V
 Stage Q 518.743 m
 Stage Topology Sallen-Key

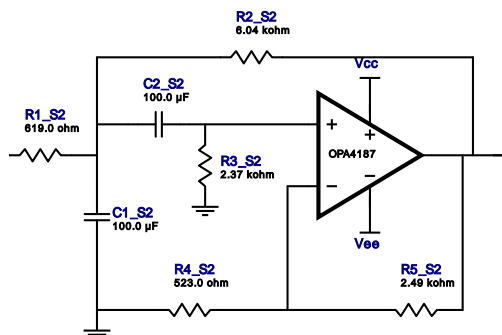

Electrical BOM

#	Name	Manufacturer	Part Number	Properties	Qty
1.	A1_S2	Texas Instruments Inc.	OPA4187	GbwTyp= 0.55MHz VccMax= 36V VccMin= 4.5V	1
2.	C1_S2	Generic	Ideal	Cap= 100.0 uF Tolerance= 2.0 %	1
3.	C2_S2	Generic	Ideal	Cap= 100.0 uF Tolerance= 2.0 %	1
4.	R1_S2	Generic	Ideal	Res= 619.0ohm Tolerance= 1%	1
5.	R2_S2	Generic	Ideal	Res= 6040.0ohm Tolerance= 1%	1
6.	R3_S2	Generic	Ideal	Res= 2370.0ohm Tolerance= 1%	1
7.	R4_S2	Generic	Ideal	Res= 523.0ohm Tolerance= 1%	1
8.	R5_S2	Generic	Ideal	Res= 2490.0ohm Tolerance= 1%	1

Filter Stage :3

Cutoff Frequency 23.737 mHz
 Min GBW Req'd 20.697 Hz
 Stage Gain 10.088 V/V
 Stage Q 784.663 m
 Stage Topology Sallen-Key

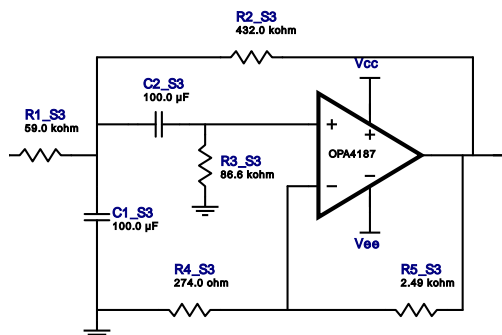

Electrical BOM

#	Name	Manufacturer	Part Number	Properties	Qty
1.	A1_S3	Texas Instruments Inc.	OPA4187	GbwTyp= 0.55MHz VccMax= 36V VccMin= 4.5V	1
2.	C1_S3	Generic	Ideal	Cap= 100.0 uF Tolerance= 2.0 %	1
3.	C2_S3	Generic	Ideal	Cap= 100.0 uF Tolerance= 2.0 %	1
4.	R1_S3	Generic	Ideal	Res= 59000.0ohm Tolerance= 1%	1
5.	R2_S3	Generic	Ideal	Res= 432000.0ohm Tolerance= 1%	1
6.	R3_S3	Generic	Ideal	Res= 86600.0ohm Tolerance= 1%	1
7.	R4_S3	Generic	Ideal	Res= 274.0ohm Tolerance= 1%	1
8.	R5_S3	Generic	Ideal	Res= 2490.0ohm Tolerance= 1%	1

Filter Stage :4

Cutoff Frequency 1.649 Hz
 Min GBW Req'd 1.321 kHz
 Stage Gain 10.088 V/V
 Stage Q 848.355 m
 Stage Topology Sallen-Key

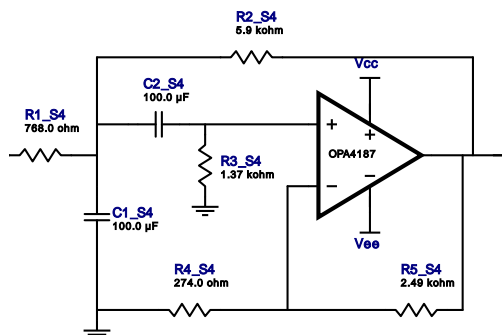

Electrical BOM

#	Name	Manufacturer	Part Number	Properties	Qty
1.	A1_S4	Texas Instruments Inc.	OPA4187	GbwTyp= 0.55MHz VccMax= 36V VccMin= 4.5V	1
2.	C1_S4	Generic	Ideal	Cap= 100.0 uF Tolerance= 2.0 %	1
3.	C2_S4	Generic	Ideal	Cap= 100.0 uF Tolerance= 2.0 %	1
4.	R1_S4	Generic	Ideal	Res= 768.0ohm Tolerance= 1%	1
5.	R2_S4	Generic	Ideal	Res= 5900.0ohm Tolerance= 1%	1
6.	R3_S4	Generic	Ideal	Res= 1370.0ohm Tolerance= 1%	1
7.	R4_S4	Generic	Ideal	Res= 274.0ohm Tolerance= 1%	1

#	Name	Manufacturer	Part Number	Properties	Qty
8.	R5_S4	Generic	Ideal	Res= 2490.0ohm Tolerance= 1%	1

Important Notice and Disclaimer

TI provides technical and reliability data (including datasheets), design resources (including reference designs), application or other design advice, web tools, safety information, and other resources AS IS and with all faults, and disclaims all warranties. These resources are intended for skilled developers designing with TI products. You are solely responsible for (1) selecting the appropriate TI products for your application, (2) designing, validating and testing your application, and (3) ensuring your application meets applicable standards, and any other safety, security, or other requirements.

These resources are subject to change without notice. TI grants you permission to use these resources only for development of an application that uses the TI products described in the resource. Other reproduction and display of these resources is prohibited. No license is granted to any other TI intellectual property right or to any third party intellectual property right. TI disclaims responsibility for, and you will fully indemnify TI and its representatives against, any claims, damages, costs, losses, and liabilities arising out of your use of these resources.

Providing these resources does not expand or otherwise alter TI's applicable Terms of Sale or other applicable terms available either on ti.com or provided in conjunction with TI products.