

FIT Rate, Failure Mode Distribution

TLV3502A-Q1

2.7-V to 5.5-V, microPower Comparator

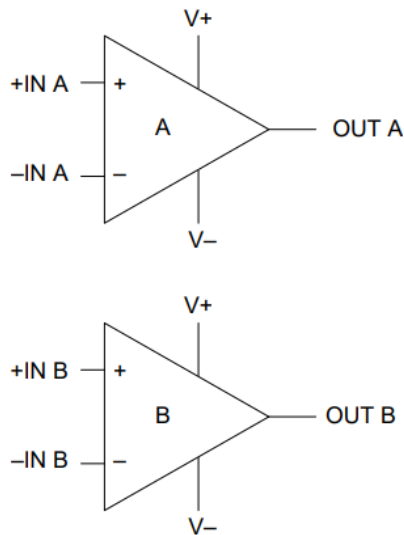

Failure Rate Mission Profile (1)	Per 10 ⁹ Hours (FIT)
Total FIT Rate	5
Die FIT Rate	3
Package FIT Rate	2

FIT Siemens Norm SN29500 (2)			
Table	Category	Ref FIT λ_{ref}	Ref Virtual Tj $\theta_{vj,1}$
4	CMOS Operational Amp, Comparators and Voltage monitors	8 FIT	45 C

Failure Modes	Failure Mode Distribution (%)
Out open (HIZ)	15%
Out saturate high	25%
Out saturate low	25%
Out functional not in specification	30%
Short circuit any two pins	5%

(1) Failure Rate, Mission Profile and Failure Mode Distribution

The failure rate and mission profile information comes from the Reliability data handbook IEC TR 62380 using the reliability modeling for Integrated circuits.

Mission Profile Automotive Control IEC TR 62380

Power dissipation 25mW

Climate type: World-wide Table 8 IEC TR 62380

Package factor lambda 3 Table 17b IEC TR 62380

Substrate Material: FR4

EOS FIT rate assumed = 0

(2) Reference failure rate, Virtual (equivalent) junction temperature

The reference failure rate and virtual junction temperature come from Siemens Norm SN29500-2 tables 1-5.

Failure rate under operating conditions are calculated from the reference failure rate and virtual junction temperature using conversion information in SN29500-2 section 4.

The failure mode distribution estimation comes from the combination of common failure modes listed in standards such as IEC 61508 and ISO 26262, the ratio of sub-circuit function size and complexity and from best engineering judgment. The failure rates listed reflect random failure events and do not include failures due to misuse or over stress.

TLV3502A-Q1 was developed using a quality-managed development process, but was not developed in accordance with the ISO 26262 standards.

IMPORTANT NOTICE FOR TI SAFETY DOCUMENTATION

Texas Instruments Incorporated ("TI") safety documentation is solely intended to assist designers ("Designers") who are developing systems that incorporate TI semiconductor products (also referred to herein as "components"). Designer understands and agrees that Designer remains responsible for using its independent analysis, evaluation and judgment in designing Designer's systems and products.

THIS INFORMATION IS PROVIDED "AS IS." TI parts are specifically designed and manufactured to be used within the electrical, thermal, mechanical and other parameters set forth in TI's product data sheets. Quality and reliability data, including safety-related information, provided by TI, including MTBF and fit rate data, is intended to facilitate an estimate of the part's performance to spec, based solely on historical observations of the part. It should not be read as indicating that any performance levels reflected in such data can be met if the part is operated outside appropriate conditions or outside the conditions described. Also, the accuracy of any projection is subject to many factors outside TI's control or knowledge; so users should carefully assess predictive value in light of additional factors as appropriate. This information could change without notice. TI's datasheet is the definitive document. TI makes no warranties and assumes no liability for applications assistance or customer product design. Customers are solely responsible to conduct sufficient engineering and additional qualification testing to determine whether a candidate device is suitable for use in their applications. Use of TI products outside limits stated in TI's published datasheet is entirely at the customer's risk, and will void the warranty if such misuse causes the part not to work.

THIS INFORMATION RELATING TO QUALITY AND RELIABILITY IS PROVIDED "AS IS." It could change without notice. Customers are solely responsible to conduct sufficient engineering and additional qualification testing to determine whether a device is suitable for use in their applications. Using TI products outside limits stated in TI's datasheet may void TI's warranty. See TI's Terms of Sale at www.ti.com.

Mailing Address: Texas Instruments, Post Office Box 655303, Dallas, Texas 75265
Copyright © 2015-2018, Texas Instruments Incorporated