

Transimpedance Amplifiers: What Op Amp Bandwidth do I Need?

John Caldwell

The transimpedance amplifier is a common op amp application with an output voltage that depends on the input current and a feedback resistor:

$$V_{OUT} = -I_{IN}R_F \quad (1)$$

Quite often I see this circuit used to amplify the output current of a photodiode as shown in Figure 1. Almost all transimpedance amplifier circuits require a feedback capacitor (C_F) in parallel with the feedback resistor to maintain stability by compensating for parasitic capacitances at the inverting node of the amplifier.

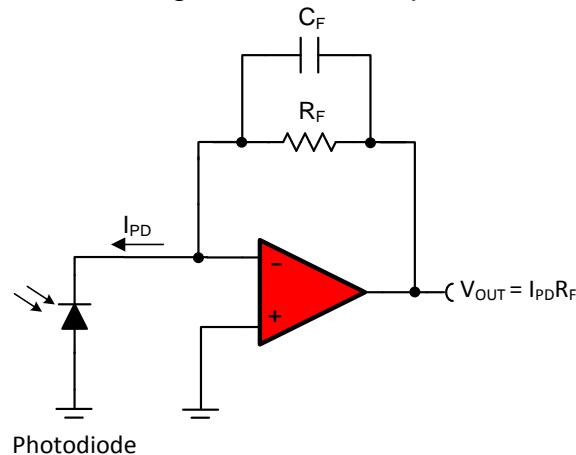

Figure 1: Feedback capacitor C_F compensates for the photodiode junction capacitance and op amp input capacitance.

Numerous articles exist on how to select a feedback capacitor when using a certain op amp, but I think this is the wrong approach. Despite what we semiconductor manufacturers love to believe, engineers don't start with an op amp and go looking for a circuit to build with it! Most engineers start with a list of performance requirements, and look for parts that will meet those requirements.

With that in mind, a better approach would be to determine the largest feedback capacitor allowable in our circuit and then select an op amp with a sufficient gain bandwidth product (GBW) to be stable with this feedback capacitor.

Here's a simple step-by-step approach to determine the required op amp bandwidth for a transimpedance amplifier.

Step 1: Determine the maximum allowable feedback capacitance.

The feedback capacitor, in combination with the feedback resistor, forms a pole in the frequency response of the amplifier:

$$f_P = \frac{1}{2\pi C_F R_F} \quad (2)$$

Above this pole frequency, the amplification of the circuit will decline. The maximum feedback capacitor value can be determined from the feedback resistor and the desired bandwidth:

$$C_F \leq \frac{1}{2\pi R_F f_P} \quad (3)$$

By keeping the feedback capacitor at or below the value calculated in equation 3, we ensure that our circuit will meet our bandwidth requirements.

Step 2: Determine the capacitance at the inverting input of the amplifier.

In Figure 2, the circuit in Figure 1 has been redrawn to show the junction capacitance of the photodiode (C_J) and the differential (C_D) and common-mode (C_{CM1} , C_{CM2}) input capacitances of the amplifier. These values are typically given in the op amp and photodiode datasheets.

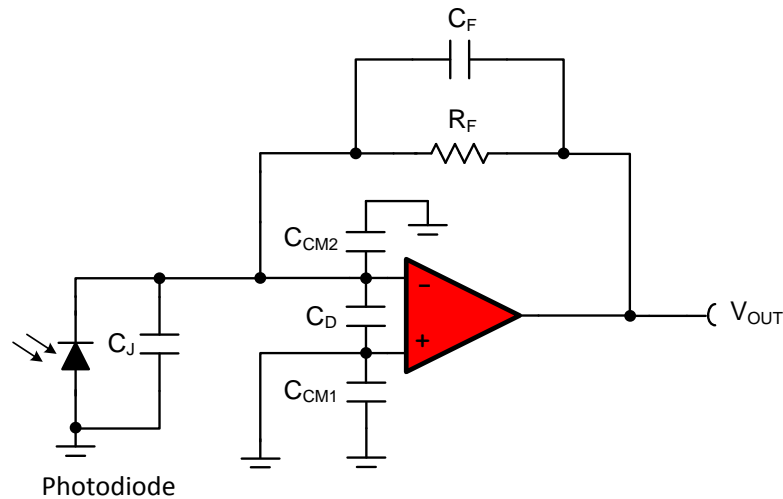

Figure 2: Transimpedance amplifier circuit showing capacitances at the inverting node.

From this illustration it is apparent that C_J , C_D , and C_{CM2} are in parallel and the capacitance at the inverting input is:

$$C_{IN} = C_J + C_D + C_{CM2} \quad (4)$$

C_{CM1} does not contribute to the input capacitance because the non-inverting terminal is grounded. C_D , and C_{CM2} may not be known at this time since we haven't yet selected a specific op amp. I often use 10pF as a reasonable guess for the sum of these values. The exact value can be substituted later to confirm the appropriateness of a specific op amp.

Now that we've determined our values for C_F and C_{IN} we're ready to calculate the required op amp bandwidth.

Step 3: Calculate the required op amp gain bandwidth product.

A basic stability analysis will reveal the logic behind this step, but if you just want the calculation you can skip to equation 10. Figure 3 shows the [TINA-TI™](#) circuit used for the analysis. The feedback loop is broken with a large inductor (L1) and a voltage

source is ac coupled to the loop through a large capacitor (C1). The loop is broken at the op amp output so that the effects of the input capacitance are included in the analysis. An ac transfer characteristic is performed and the post-processor is used to generate the open-loop gain (A_{OL}) and noise gain ($1/\beta$) curves (Figure 2).

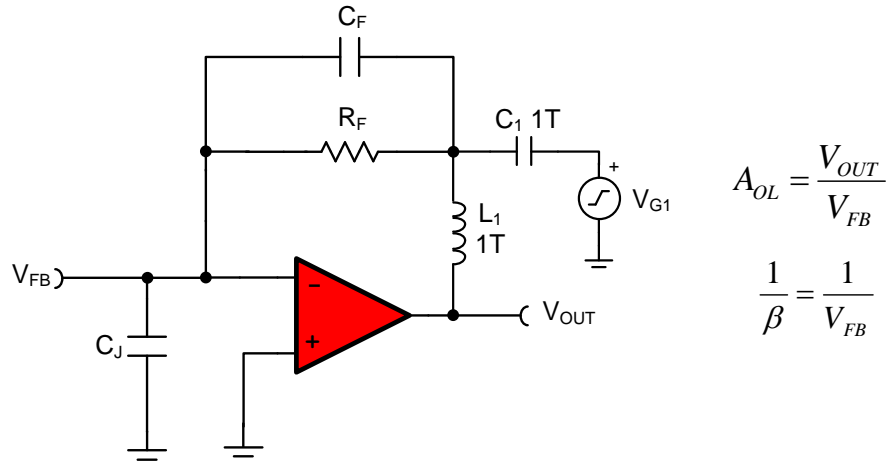

Figure 3: Breaking the feedback of a transimpedance amplifier and generating AOL and 1/β curves.

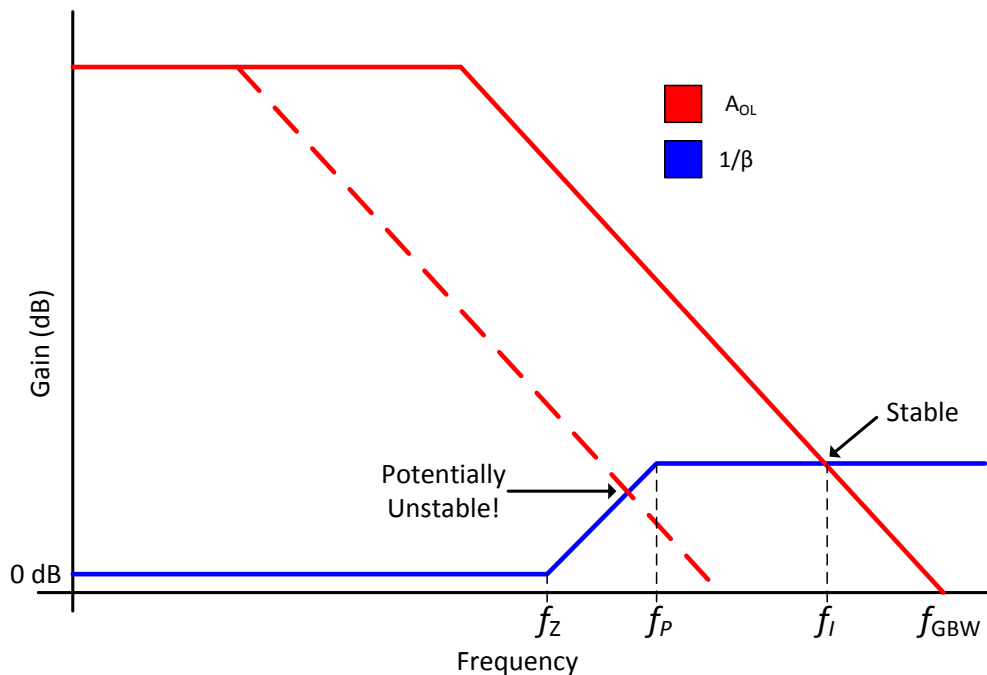

Figure 4: A_{OL} and $1/\beta$ plot for a typical transimpedance amplifier circuit.

On the $1/\beta$ curve there are 3 points of interest. First, there is a zero at the frequency:

$$f_Z = \frac{1}{2\pi(C_F + C_{IN})R_F} \quad (5)$$

Above this frequency, the $1/\beta$ curve will increase a rate of 20dB per decade. Next, there is a pole, at the frequency:

$$f_P = \frac{1}{2\pi C_F R_F} \quad (6)$$

which will cause the $1/\beta$ curve to “flatten out.” Finally, the $1/\beta$ curve intersects the AOL curve at the frequency:

$$f_I = \frac{C_F}{C_{IN} + C_F} f_{GBW} \quad (7)$$

In equation 7, f_{GBW} is the unity gain bandwidth of the op amp. In order to maintain stability, the A_{OL} curve must intersect the $1/\beta$ curve when the $1/\beta$ curve is flat (assuming a unity gain stable op amp). If the A_{OL} curve intersects the $1/\beta$ curve when the $1/\beta$ curve is rising, as shown by the dashed line in Figure 4, the circuit may oscillate. This gives us the rule:

$$f_I > f_P \quad (8)$$

Inserting the equations for f_I and f_P into this rule and solving for unity gain bandwidth, we arrive at a useful equation:

$$\frac{C_F}{C_{IN} + C_F} f_{GBW} > \frac{1}{2\pi R_F C_F} \quad (9)$$

$$f_{GBW} > \frac{C_{IN} + C_F}{2\pi R_F C_F^2} \quad (10)$$

Equation 10 eliminates one of the mysteries when selecting an op amp for your transimpedance amplifier design. Choosing an op amp with adequate bandwidth not only ensures you have sufficient signal bandwidth, but also helps to avoid potential stability headaches!

Design Example

Now I’ll apply this process to a design example and compare the performance of the circuit using two op amps. One op amp will meet the gain bandwidth requirements we calculate and the other will not. The requirements for this design example are given in table 1.

Table 1: Example performance requirements for a transimpedance amplifier

Specification	Value
Power Supply Voltages	+/- 2.5V
Gain	1M (V/A)
I/V Bandwidth	>100 kHz
Photodiode Capacitance	72pF

To start, we calculate the maximum feedback capacitance for the circuit to be stable and still meet our bandwidth goal:

$$C_F \leq \frac{1}{2\pi R_F f_{-3dB}} \leq \frac{1}{2\pi(1M\Omega)(100kHz)} \leq 1.59pF \quad (11)$$

Next, we determine the capacitance at the inverting input of the amplifier. Because we haven't selected an op amp yet for our circuit we do not know the values of C_D and C_{CM2} . Remember that I suggested 10pF as a reasonable guess for the sum of these capacitances.

$$C_{IN} = C_J + C_D + C_{CM2} = 72pF + 10pF = 82pF \quad (12)$$

Finally we can calculate the gain bandwidth requirements for the op amp:

$$f_{GBW} > \frac{C_{IN} + C_F}{2\pi R_F C_F^2} > \frac{82pF + 1.59pF}{2\pi(1M\Omega)(1.59pF)^2} > 5.26MHz \quad (13)$$

For this example, I'll compare the two op amps shown in table 2:

Table 2: Gain bandwidth product comparison of two op amps for the design example.

Op Amp	GBW
OPA313	1 MHz
OPA316	10 MHz

From our previous calculations, we know that one of these op amps, the OPA313, does not have sufficient bandwidth for our circuit. But how does this actually affect the operation of the circuit?

Phase Margin Comparison

Phase margin is one metric of stability which compares the phase of the loop gain ($A_{OL} * \beta$) of an amplifier to 180 degrees at the point where loop gain equals 0dB. A phase margin of 0 degrees would indicate that negative feedback has become positive feedback and the system is unstable.

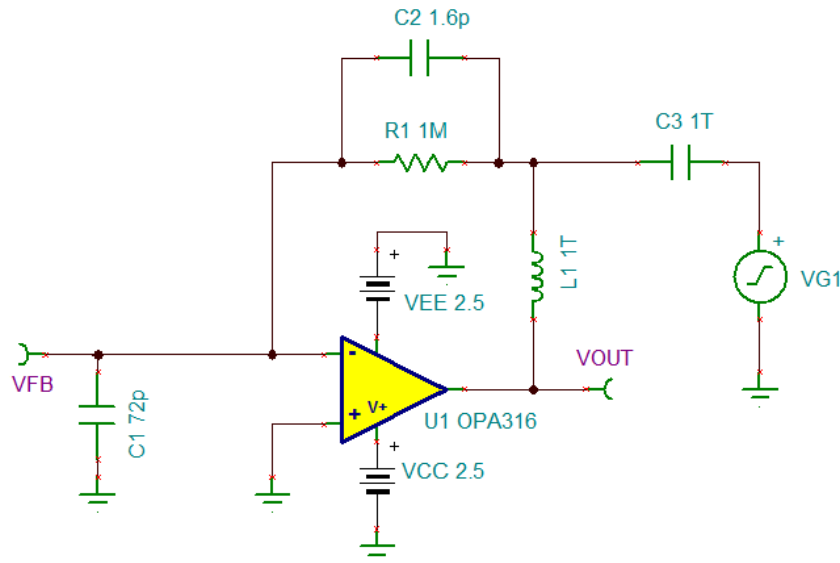

Figure 5: TINA-TI™ simulation schematic for evaluating phase margin.

Phase margin can be measured using the circuit from part II (Figure 1) which breaks the feedback loop. The phase of the $A_{OL} * \beta$ voltage is measured (Vout probe) at the frequency where its magnitude is 0 dB. Figure 2 shows the result of an ac transfer characteristic simulation in Tina-TI using the OPA316. From the cursors we can see that $A_{OL} * \beta = 0\text{dB}$ at 232.455 kHz and the phase margin is 66.66 degrees.

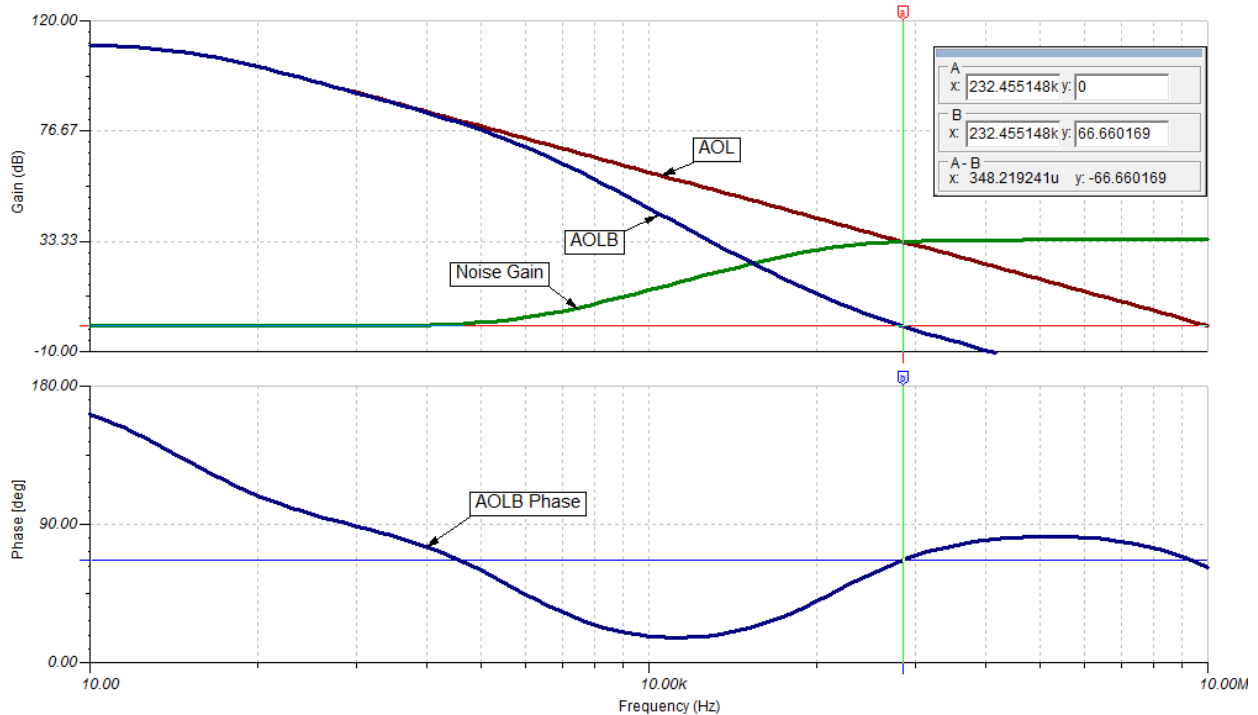

Figure 6: Bode plot of the loop gain for determining phase margin

Repeating this analysis with the OPA313 gives a phase margin of 31.65 degrees. Technically, the OPA313 is still stable with this amount of phase margin but it would not be considered a robust design. If a large number of these circuits were produced, a few may be unstable due to the tolerances of the op amp's specifications.

Step Response Comparison

Reduced phase margin has other ramifications. For example, it causes overshoot and ringing in the circuit step response. To show this effect I applied a 1uA current step (IG1) to the input of the circuit and measured the time required to settle to 0.1% of the ideal value using a transient simulation.

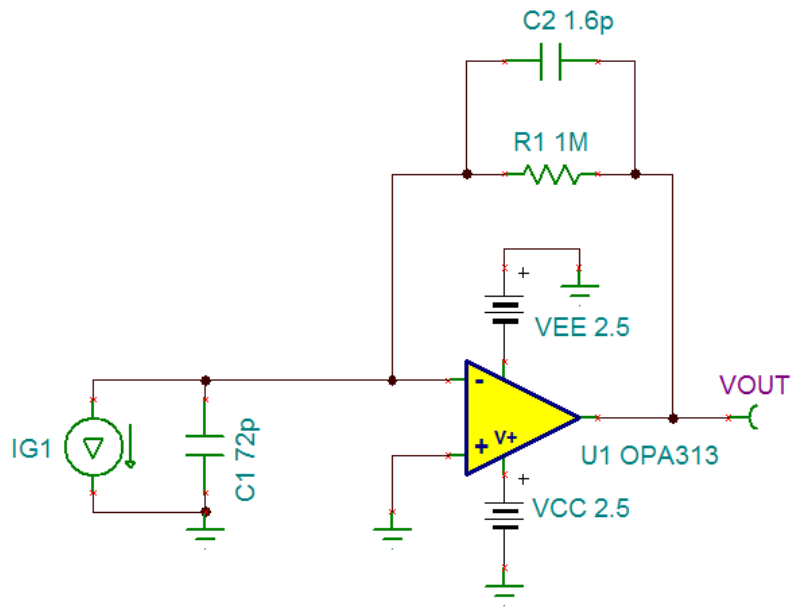

Figure 7: A 1uA current step is applied to the input to simulate step response.

The step response of the OPA316 shows minimal overshoot and settles to 0.1% in 13μs. Conversely, the OPA313 shows significant overshoot and ringing in its response and requires 75μs to settle to 0.1%

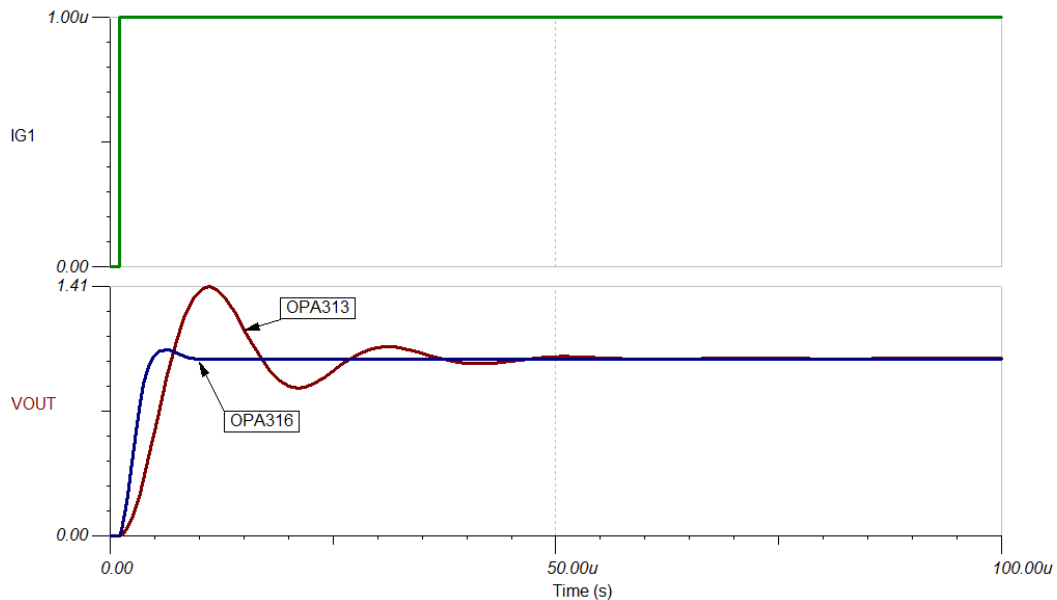

Figure 8: Step response of the OPA316 (blue) and OPA313 (red) for a 1uA input current step (green).

Amplitude Response Comparison

Finally, the reduced phase margin will cause peaking in the transfer function of the circuit. Figure 9 displays the amplitude response for the two op amps. The OPA313's

transfer function exhibits a 5 dB peak in gain which may not be acceptable. Even worse, the -3dB point when using the OPA313 is 78.47 kHz.

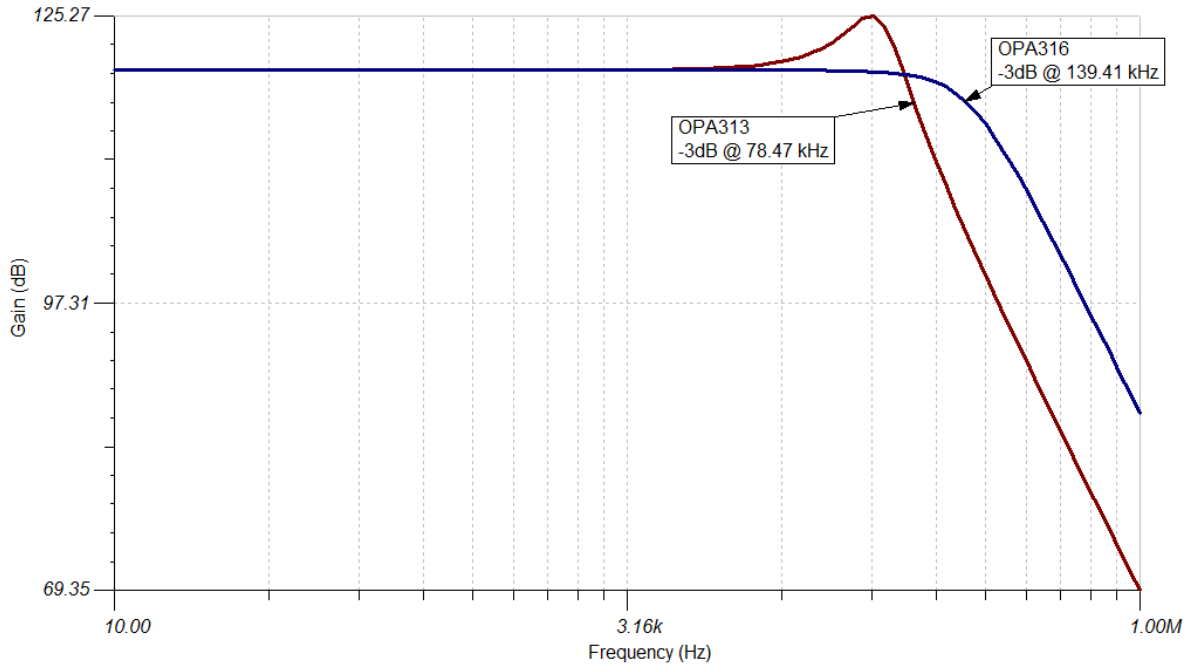

Figure 9: Frequency response comparison of the transimpedance amplifier built with the OPA313 (red) and OPA316 (blue).

On the other hand the OPA316’s transfer function does not show peaking and has a -3dB point of 134.41 kHz.

Conclusion

A look at the scoreboard for this comparison shows the OPA316 is better able to meet our design requirements:

Op Amp	GBW	PM (Deg)	Settling (0.1%)	BW
OPA313	1 MHz	31.65°	75µs	78.47 kHz
OPA316	10 MHz	66.68°	13µs	139.41 kHz

But this should not be a surprise! Our 3-step process resulted in a minimum gain bandwidth requirement of 5.26 MHz. Below this value the stability, settling, and bandwidth of the circuit is compromised. Hopefully the 3-step process outlined in this document will help you to quickly choose the appropriate op amp for your transimpedance amplifier; or at least help narrow the choice down from the 1375 options from TI!