

# A Simple Pressure Sensor Signal Conditioning Circuit

Note: APP-101  
Revised: August 1999

Contributors:  
Richard Markell - Linear Technology

## INTRODUCTION

A simple signal conditioning circuit should allow the output of the amplifier to be independent of the sensor used, providing interchangeability and high level output at very low cost. A laser trimmed resistor on the sensor's compensation board programs the gain of an external amplifier to normalize the pressure sensitivity variation.

## SIMPLE SIGNAL CONDITIONING CIRCUIT

The signal conditioning circuit shown in Figure 1 provides a precision constant current source for sensor excitation and an instrumentation amplifier with the gain programmed by sensor feedback resistor  $r$ .

For a detailed discussion of the compensation circuit, and for output voltages other than 0-5V, please refer to Application Notes TN-001 and APP-103 to APP-105.

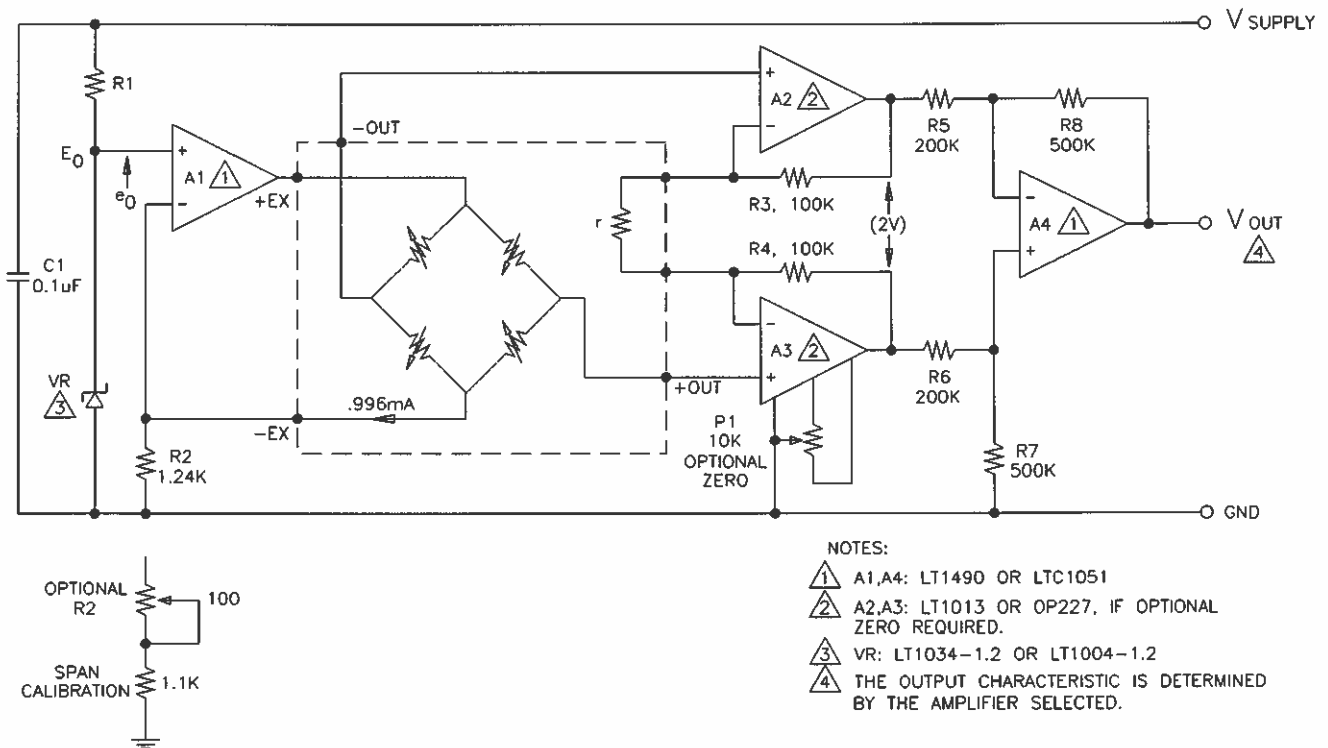

Figure 1. Basic Signal Conditioning Circuit

Application Notes

# A Simple Pressure Sensor Signal Conditioning Circuit

## CIRCUIT DETAILS

The current source is controlled by the  $\pm 1\%$  band-gap reference diode, VR. The reference current  $I_O$  is defined by:

$$I_O = (E_O - e_O)/R_2 \quad [1]$$

where:  $E_O$  - diode reference voltage:  $1.235V \pm 1\%$  (LT1034-1.2 or LT1004-1.2)  
 $e_O$  - offset of amplifier  $A_1$  ( $\sim 0$ )  
 $R_2$  - current set resistor

Selecting amplifier  $A_1$  with an offset voltage below 1 mV and a  $\pm 1\%$  tolerance of resistor  $R_2$  delivers current  $I_O = 0.996$  mA with typical accuracy of  $\pm 1.4\%$ .

The differential input stage of the instrumentation amplifier,  $A_3$ - $A_2$  has a gain of  $\text{Gain} = 1 + (R_3 + R_4)/r$ .

The gain set resistor  $r$  is trimmed for  $R_3 = R_4 = 100K$  and a differential output voltage of 2V.

## OPTIONAL ZERO ADJUST

If the optional zero adjustment is required, use OP227 amplifiers instead of the LT1013 and add the zeroing potentiometer P1.

The zero range is typically  $\pm 4$  mV referenced to the input with a differential offset below 0.5 mV. This leaves about a  $\pm 3.5$  mV zeroing range for the compensation of the sensor offset which is typically below  $\pm 1$  mV.

## OUTPUT

The output stage of the instrumentation amplifier provides additional amplification  $R_8/R_5$  and translates the differential floating voltage from the first stage into a single ended output voltage. The equation for the overall output voltage is:

$$V_{out} = 2 \cdot A \cdot R_8 / R_5 = 5.000V @ A = 1 \quad [3]$$

$A$  is the Ratio between the actual excitation current  $I_O$  and the specified current.

## ACCURACY AND CALIBRATION

The overall accuracy of the span is effected by the accuracy of feedback resistors  $R_3$  through  $R_8$ . Using  $\pm 1\%$  resistors such as Mepco/Electra 5063Z, the typical gain error will be about  $\pm 0.24\%$ . The accuracy error may be decreased when matched thin film resistors are used such as Beckman 694-3-A. The combined span error of the entire signal conditioning circuit at a reference temperature will then typically be about 1.1% without any adjustment or pressure testing. This will be superimposed on the sensor's accuracy of  $\pm 1\%$ .

## OPTIONAL SPAN CALIBRATION

If additional calibration and normalization is desired, resistor  $R_2$  can be replaced with a series combination of a potentiometer and a resistor (Figure 1). The potentiometer can be adjusted to set the bridge excitation current ( $I$ ) to achieve the exact span voltage ( $S$ ) with full scale pressure applied to the sensor.

## GAIN ERROR

If no pressure source is available, the gain error of the amplifier can be reduced by using the procedure outlined below. This method may be used instead of using the precision resistors discussed above for  $R_2$  through  $R_8$ . The sensor span error of  $\pm 1\%$  will remain, however.

Calibration procedure:

- replace resistor  $r$  with an external resistor  $7.50 K \pm 0.1\%$
- check gain  $K$  of the instrumentation amplifier and calculate the gain ratio  $X$  (in reference to the idea that gain  $KO = 69.028V/V$ ), where  $X = K/KO$
- set current  $I_O = 0.996/X$  (mA) by adjusting the potentiometer, thus completing calibration.

Assuming a  $6.4 k\Omega$  ( $50^\circ C$ ) maximum bridge resistance, a 0.996 mA bridge current and a 1.2V diode reference voltage, it follows that the maximum output voltage of amplifier  $A1$  can approach 7.4V. Also, the positive saturation voltage at 1 mA out-put current for the LTC1051 amplifier is 0.5V. Therefore, the minimum excitation voltage which is a function of the current source and amplifiers used would be 7.9V ( $7.4V + 0.5V$ ) for the LTC1051. For the LT1490, the minimum excitation voltage should be 7.6V. The maximum excitation voltage is limited by the voltage handling characteristics of the specific amplifier used.

Internet: www.msiausa.com

Tel: 1-757-766-1500

North America Toll Free: 1-800-745-8008

Fax: 1-757-766-4297

# A Simple Pressure Sensor Signal Conditioning Circuit

## OUTPUT SPAN $S_O$ VARIATION

Resistor  $r$  is laser trimmed for each unit using the following equation:

$$r = \frac{2R_F}{\frac{V_{amp}}{S_i} - I} \quad [4]$$

where:  $S_i$  = sensor span value (V) at a reference excitation current ( $I_O = 0.996$  mA)

$r$  = resistance in (k)

$R_F$  = 100K feedback resistor

$V_{amp}$  = amplified output

The output span  $S_O$  at the differential output of amplifiers  $A_3$ -  $A_2$  (see Figure 1) for any other feedback resistor  $R$  in  $K\Omega$  is given by:

$$S_O = AS \left( \frac{r+2R}{r} \right) = 2A \left[ \frac{R}{100} + S_i \frac{(100-R)}{200} \right] \quad [5]$$

where:  $A = I/I_O$ , ratio of excitation current  $I$  to reference current  $I_O$

If 100  $k\Omega$  feedback resistors are used, the expression for output span is simplified to:

$$S_c = 2A \quad [6]$$

and is constant for all sensors independent of sensor span  $S_i$ . The output span is also independent of the pressure range of the sensor. For other values of the feedback resistors ( $R$ ), the output span ( $S_O$ ) will vary with the sensor span ( $S_i$ ). Assuming  $I = I_O$ , we can calculate  $S_O$  variations.

**Table 1. Output Span ( $S_O$ ) Variation**

R	$S_O(S_i=40$ mV)	$S_O(S_i=90$ mV)	$S_O$ variation ( $\pm\%$ )
50 K	1.0200	1.0450	1.23
75 K	1.5100	1.5225	0.41
99 K	1.9804	1.9809	0.01
100 K	2.0000	2.0000	0.00
101 K	2.0196	2.0191	0.01
200 K	3.9600	3.9100	0.63
500 K	9.8400	9.6400	1.0

As seen in Table 1, a large deviation from the optimum feedback resistance of 100 k is tolerable while maintaining transducer interchangeability.

For the optimum feedback resistance (100 k), calibration accuracy is a function of the accuracy of the excitation current, feedback resistors and sensor trimming. The inaccuracy caused by the excitation current and feedback resistors can be made negligible by the use of precision components. Therefore without pressure testing, a 1% system accuracy can be achieved.

The standard gain programming resistor  $r$  has a TCR  $\leq \pm 50$  ppm/ $^{\circ}C$  and a trimming range of 2.5 to 12.5  $k\Omega$ . For volume orders, a custom trimming algorithm can be made to achieve any desired output span.